

Ditch Witch[®]

JT4020

All Terrain Rack & Pinion

ISSUE NO. 04PL06/11

For Replacement Copy Order **P/N 053-1216**

This manual contains information concerning the following models:
JT4020 All Terrain Rack & Pinion Directional Drilling System

This product is covered by one or more of the following patents:

US B1 4,858,704; 4,953,638; 5,148,880; 5,242,026; 5,341,887; 5,490,569; 5,684,466;
5,713,423; 5,794,719; 5,880,680; 5,941,322; 6,085,852; 6,109,371; 6,179,065; 6,216,803;
6,250,403; 6,250,404; 6,290,606; 6,311,790; 6,411,094; 6,543,551; 6,550,547; 6,672,409;
6,739,413; 6,776,246; 6,808,210; 6,827,158; RE37,450; RE37,923; RE37,975; RE38,418

AU 689,533; 706,544; 718,034, 755,862

CA 2,156,398

FR 674,093

DE 694 17 019; 695 29 634; 297 01 406

EP 0683845; 0674093; 0817901; 0846841

GB 2,209,239; 2,312,006; EP674,093; EP846,841

JP 3,458,247

Other U.S. and foreign patents pending

Copyright 2008, 2011 by The Charles Machine Works, Inc.



**Ditch
Witch**

, Ditch Witch, CMW, AutoCrowd, Jet Trac, Roto Witch, Subsite, Fluid Miser, Power Pipe, Super Witch, Pierce Arrow, The Underground, The Underground Authority Worldwide, and Zahn are registered trademarks of The Charles Machine Works, Inc.

ID0201755

FOREWORD

This manual contains illustrated parts lists to help you select quality ProTech[®] Replacement parts for your Ditch Witch[®] equipment. Using other replacement parts will lessen the productivity of your equipment.

- ◆ Part numbers enclosed in a box are no longer available from The Charles Machine Works, Inc. Your local Ditch Witch dealer may be able to locate the part for you.
- ◆ Footnotes provide more information to help you identify parts shown in the manual.
- ◆ Assembly instructions and Tech Bits articles referenced in footnotes are available through your local Ditch Witch dealer.
- ◆ Description and specifications in this book were current at publication. However, The Charles Machine Works, Inc. reserves the right to improve equipment, so this manual might not reflect the most current improvements.
- ◆ Instructions on recommended equipment use and maintenance are in the Operator's Manual that was shipped with your equipment.

Keep the following in mind when ordering ProTech replacement parts:

- ◆ Specify parts you need by part number and description, not by illustration reference numbers.
- ◆ Have equipment model and serial number on hand to help ensure you get the right parts for your machine whether it's old or new.

Thank you for buying and using Ditch Witch equipment and ProTech replacement parts.

WARRANTY

DW WARRANTY Policy
July, 2005

POLICY 1: DITCH WITCH® EQUIPMENT AND REPLACEMENT PARTS LIMITED WARRANTY POLICY

Subject to the limitation and exclusions herein, free replacement parts will be provided at any authorized Ditch Witch dealership for any Ditch Witch equipment or parts manufactured by The Charles Machine Works, Inc. (CMW) that fail due to a defect in material or workmanship within one (1) year of first commercial use (Exception: 2 years for all SK500 Attachments). Free labor will be provided at any authorized Ditch Witch dealership for installation of parts under this warranty during the first year following "initial commercial" use of the serial numbered Ditch Witch equipment on which it is installed. The customer is responsible for transporting their equipment to an authorized Ditch Witch dealership for all warranty work.

EXCLUSIONS FROM PRODUCT WARRANTY

- All incidental or consequential damages.
- All defects, damages, or injuries caused by misuse, abuse, improper installation, alteration, neglect, or uses other than those for which products were intended.
- All defects, damages, or injuries caused by improper training, operation, or servicing of products in a manner inconsistent with manufacturer's recommendations.
- All engines and engine accessories (these are covered by original manufacturer's warranty).
- Tires, belts, and other parts which are subject to another manufacturer's warranty. (Such warranty will be available to purchaser.)
- ALL IMPLIED WARRANTIES NOT EXPRESSLY STATED HEREIN, INCLUDING ANY WARRANTY OF FITNESS FOR A PARTICULAR PURPOSE AND MERCHANTABILITY.

IF THE PRODUCTS ARE PURCHASED FOR COMMERCIAL PURPOSES, AS DEFINED BY THE UNIFORM COMMERCIAL CODE, THEN THERE ARE NO WARRANTIES WHICH EXTEND BEYOND THE FACE HEREOF AND THERE ARE NO IMPLIED WARRANTIES OF ANY KIND WHICH EXTEND TO A COMMERCIAL BUYER. ALL OTHER PROVISIONS OF THIS LIMITED WARRANTY APPLY INCLUDING THE DUTIES IMPOSED.

Ditch Witch products have been tested to deliver acceptable performance in most conditions. This does not imply they will deliver acceptable performance in all conditions. Therefore, to assure suitability, products should be operated under anticipated working conditions prior to purchase.

Defects will be determined by an inspection within thirty (30) days of the date of failure of the product or part by CMW or its authorized dealer. CMW will provide the location of its inspection facilities or it's nearest authorized dealer upon inquiry. CMW reserves the right to supply remanufactured replacement parts under this warranty as it deems appropriate.

Extended warranties are available upon request from your local Ditch Witch dealer or CMW.

Some states do not allow exclusion or limitation of incidental or consequential damages, so the above limitation or exclusion may not apply. Further, some states do not allow exclusion of or limitation of how long an implied warranty lasts, so the above limitation may not apply. This limited warranty gives product owner specific legal rights and the product owner may also have other rights which vary from state to state.

For information regarding this limited warranty, contact CMW's Product Support Department, P.O. Box 66, Perry, OK 73077-0066, or contact your local Ditch Witch dealer.

CONTENTS

Decals

Decal Location - AT/JT4020 Rack & Pinion 8

Engine Components

Air Filter System 30
 Battery Covers 46
 Charge Air 36
 Deaeration 38
 Engine 14
 Engine Covers 40
 Engine Mounts 20
 Engine Oil Drain 28
 Engine Skid 22
 Engine Skid Edging 24
 Fan & Shroud Assembly 18
 Fan Drive 16
 Gauge Panel 48
 Radiator 32
 Radiator Mount 34
 Sound Insulation 44

Operator's Station

Console 58
 Console Gauges 62
 Dual Axis Joystick 66
 Left Console Relay Panel 60
 Operator Station 52
 Seat-Belts-Cover 56

Track Frame & Main Frame

2-Post ROPS 82
 Drill Frame Covers/Locks/Switches 84
 Fuel Tank 80
 Grease Cylinder 76
 Hose Retaining Clamp 86
 Idler 72
 Rear Stabilizer 78
 Roller 74
 Track Group 70

Anchor Systems

Anchor 104
 Anchor Valve & Cover Mount 92
 Auger Anchor Base 90
 Flange Hex Driver Assembly 102
 Front Pipe Guide - All Terrain Only 94
 Front Pipe Guide - JT4020 Mach 1 Only 96
 Left Auger Anchor Drive 100
 Right Auger Anchor Drive 98

Lubricator

Applicator 114
 Auto-Luber Assembly 110
 Grease Pump 112
 Grease Pump Mounting 108

Drill Frame

Carriage AT 128
 Carriage JT 130
 Clamp Assembly 144
 Hose Track 142
 Hydraulic Cylinder (4.5" X 2.25" X2.75") 148
 Pivot 118
 Rack Mounting 120
 Rotation Gearbox - AT4020 Only 136
 Rotation Gearbox - JT42M1/JT42T2 Only 132
 Spindle Drive 140
 Thrust Coupler & Shock 122
 Thrust Drive Gearbox 126
 Thrust Drive Rack 124
 Wrench Pipe Guide 146

Pipe Loader System

Front Pipe Loader Shuttle 156
 Gripper Cylinder 162
 Guard Lock Pin 174
 Pipe Box - AT42T2 Pipe 168
 Pipe Box - JT42T2 Pipe 170
 Pipe Loader Gripper 160
 Pipe Loader Lifters 154
 Pipe Loader Shuttle Drive 152
 Rear Pipe Loader Shuttle 158
 Shuttle Guard 172
 Shuttle Stop 164
 Shuttle Stop Indicator 166

Fluid System

Antifreeze Tank 194
 Fluid Pump (Fluid End) 70 Gpm 186
 Fluid Pump (Fluid End) 120 Gpm 184
 Fluid Pump (Power End) 188
 Fluid Pump (Power End) 190
 Fluid Pump Plumbing - 70 Gpm 180
 Fluid System Plumbing 182
 Mud Pump Plumbing - 120 Gpm 178
 Pump Mount-70gpm/120gpm Fluid Pumps 192
 Wash Wand 196

Continued

ID0202363

CONTENTS

Hydraulics

Anchor Supply Hydraulics	270
Anchor Valve Pres/Return Hydraulic.....	272
AT Load Sense/Inner Rotation Gauge	242
Auxiliary Supply & Return Hydraulic.....	284
Auxiliary Valve.....	282
Case Drains, AT.....	222
Case Drains, JT	226
Fluid Check Supply Hydraulic	238
Frame Tilt Hydraulics	290
Front Wrench Hydraulics	264
Greaser Hydraulics	300
Gripper Hydraulics	298
Hydraulic Cylinder (2.0" X 1.0" X 8.0")	306
Hydraulic Cylinder (2.0" X 1.25" X 24.0").....	308
Hydraulic Cylinder (3.0" X 1.75" X 8.0")	310
Hydraulic Cylinders (4.0" X 2.0").....	312
Hydraulic Cylinder (4.0" X 2.0" X 10.0")	314
Hydraulic Reservoir.....	206
Inner Rotation & Thrust Hydraulic.....	244
Inner Rotation Control Kit.....	246
Left Anchor Motor Hydraulics.....	276
Left Anchor Thrust Cylinder	280
Main Frame Bulkheads	210
Mud Motor Hydraulics	256
Oil Cooler Hydraulics	200
Oil Cooler Return Hydraulics.....	202
Oil Return Hydraulics	204
Outer Rotation Hydraulics	218
Outer Rotation Hydraulics - Begins	220
Pipe Lifter Hydraulics	296
Pipe Loader Supply & Return.....	292
Pipe Shuttle Hydraulics	294
Rear Wrench Hydraulics	266
Remote Filter	228
Right Anchor Motor Hydraulics	274
Right Anchor Thrust Cylinder	278
Rotation Gauge Valve.....	214
Rotation Hydraulics	212
Rotation Test Ports	216
Rotation, Thrust, & Mud Gauges	208
Seat Rotation Hydraulics.....	304
Shuttle Stop Hydraulics.....	288
Spindle Brake, Thrust Brake,& 2-Spd	232
Stabilizer Hydraulics.....	286
Thrust Drive Hydraulics.....	254
Thrust Hydraulics	252
Thrust Valve, JT	250
Thrust/Track Drive Pump Hydraulics	248
Track 2-Speed, Rack Only.....	230

Track Brake	236
Track Case Drain Hydraulics	260
Track Drive Hydraulics.....	258
Track Load Sense Hydraulics.....	240
Track Shift	234
Wrench Hydraulics	262
Wrench Rotate Hydraulics	268

Electrical

Alarm And Strobe Light.....	324
Battery.....	320
Controller J-Box	328
Panel.....	322
Relay Panel.....	326
Right Console	318

Accessories

Drilling Fluid Transfer.....	332
Grounding Hardware (ESS)	340
Heated Hose Kit.....	336
Mud Mixing Accessories	334
Tool Box.....	344
Vandal Covers	342
Working Light.....	338

Miscellaneous

Bolt/Nut Torque Chart	348
Filters	352
Optional Kits.....	352
Parts Manual Change Request	353
Related Publications	352
Replacement O-Ring Chart.....	351
Warranty Registration	356

DECALS

DECAL LOCATION AT/JT4020 RACK & PINION

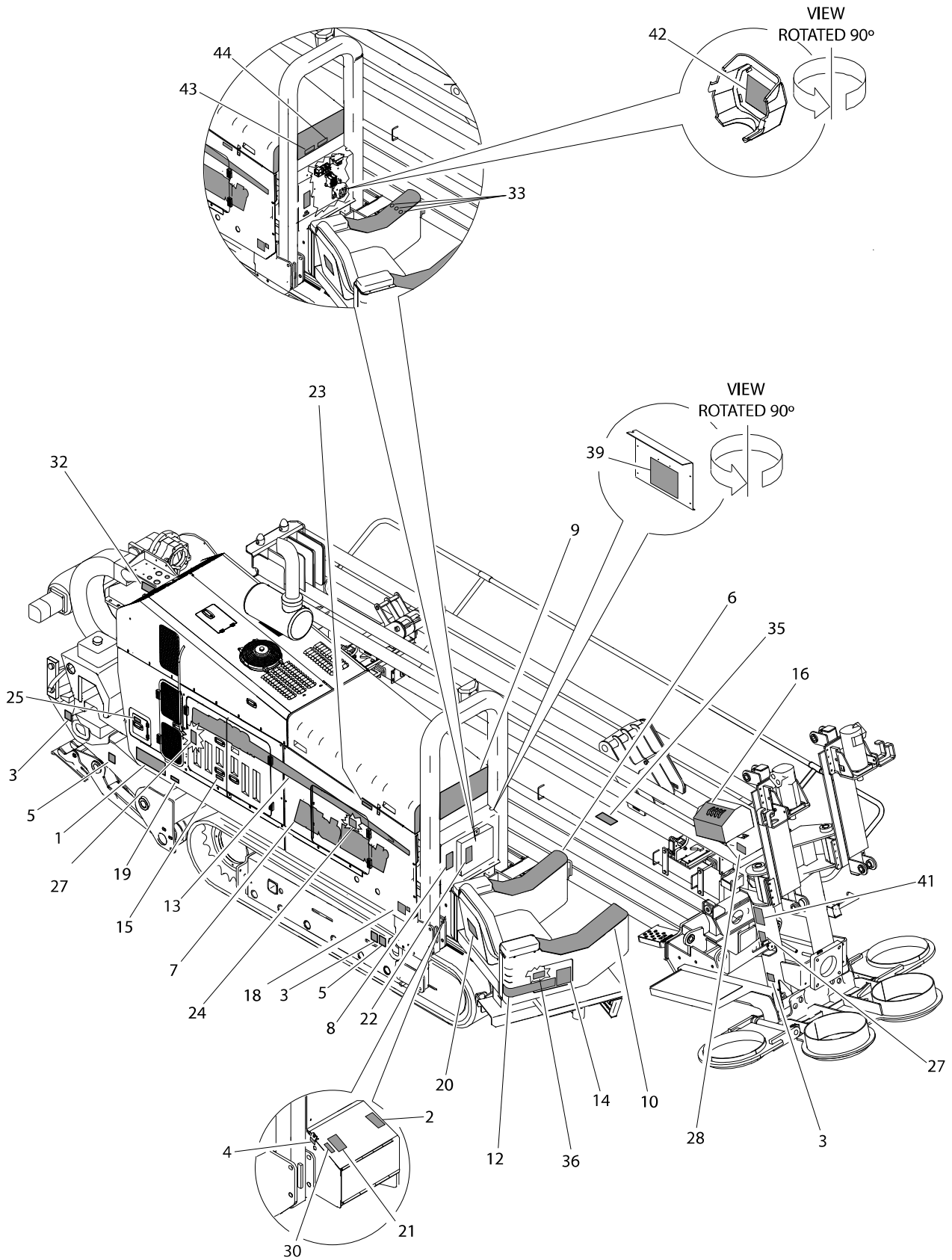

DECAL LOCATION AT/JT4020 RACK & PINION

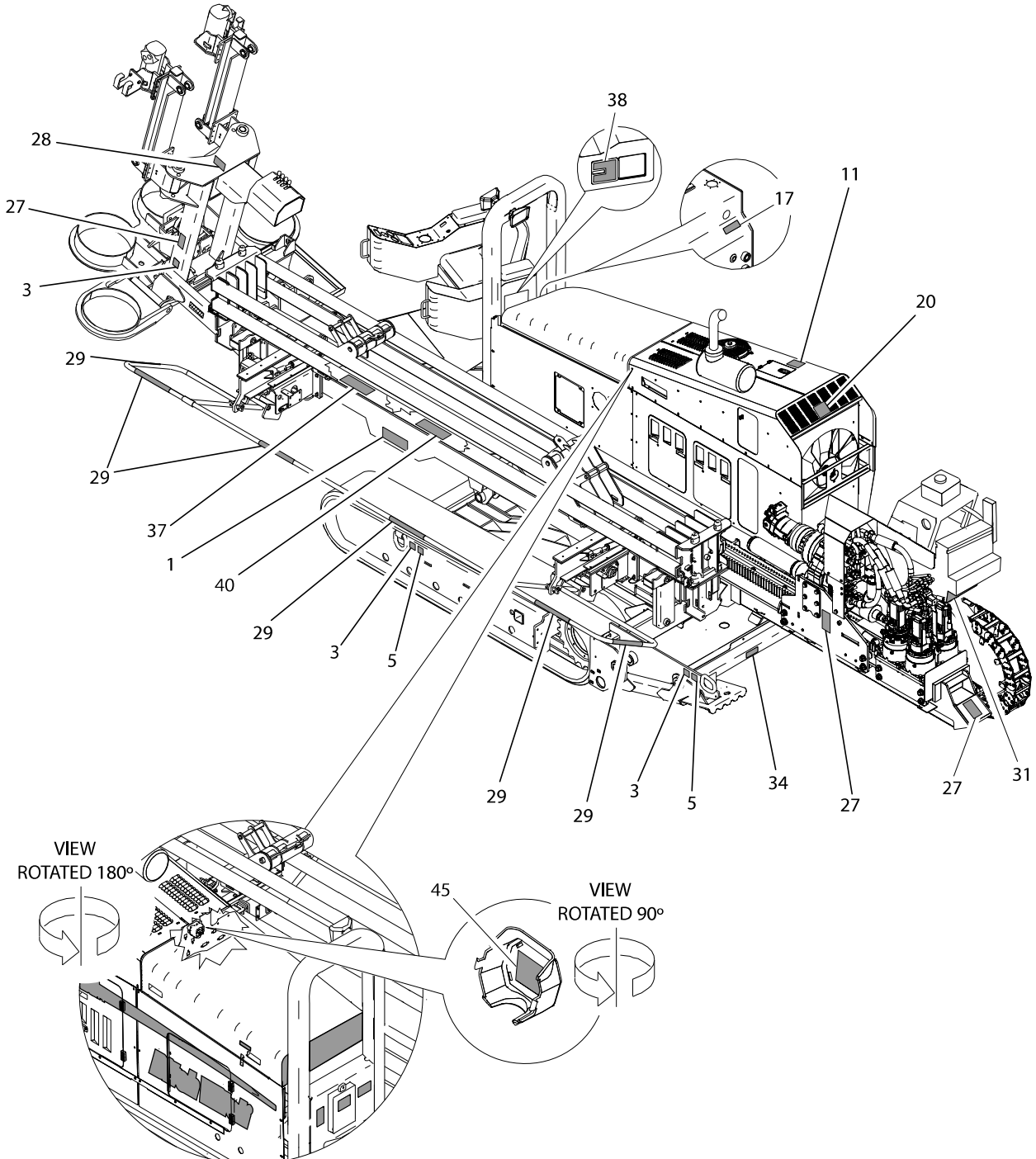

DECAL LOCATION AT/JT4020 RACK & PINION

REF NO.	PART NUMBER	QTY	DESCRIPTION	REMARKS
	270-1116		DECAL KIT - AT42T3	
	270-1117		DECAL KIT - JT42T3	
1	274-049	2	DANGER ELECTROCUTION	
2	274-050	1	WARNING JOB SITE HAZARD	
3	274-318	6	TIE DOWN LOCATION	
4	274-375	1	MASTER DISCONNECT SWITCH	
5	274-442	4	LIFT LOCATION	
6	700-060	1	JT40AT LEFT CONSOLE	
7	273-539	1	DITCH WITCH LOGOTYPE	
8	274-780	1	JET TRAC PATENT (S)	
9	270-1118	1	JT4020 T3 INSTRUMENT PANEL	
10	700-232	1	IGNITION - JOYSTICK - GUAGE	
11	273-452	1	NOTICE COOLANT	
12	274-877	AR	GRAPHIC STRIPE	SEE FOOTNOTE 5
13	270-1115	1	JT4020 MODEL ID W/STRIPE	SEE FOOTNOTE 2
	270-1114	1	JT4020 AT MODEL ID W/STRIPE	SEE FOOTNOTE 1
14	275-307	1	DITCH WITCH EMLEM	
15	275-400	1	NOTICE OIL LEVEL	
16	273-181	1	ANCHOR ROTATION - THRUST	
17	274-198	1	NOTICE OIL LEVEL	
18	273-016	1	SOUND POWER II	SEE FOOTNOTE 3
19	275-497	1	OIL DRAIN I.D.	
20	275-449	2	DITCH WITCH LOGO PLACARD	
21	275-033	1	NOTICE ELECTRICAL SYSTEM	
22	275-048	1	IMPORTANT SAFETY RULES	
23	275-120	1	RESERVOIR (THF)	
24	273-275	1	AT/JT INNER SPINDLE	SEE FOOTNOTE 1
25	275-148	1	FUEL TANK (DIESEL)	
26	273-267	2	DITCH WITCH BATTERY	SEE FOOTNOTE 4
27	275-184	5	WARNING MOVING PARTS	
28	275-197	2	DANGER ROTATING SHAFT	
29	275-230	6	WARNING STRIPE (1.750" X 18")	
30	275-203	1	BATTERY	
31	700-061	1	WASH WAND	
32	275-341	1	WARNING SLIDING PARTS	
33	274-940	3	INDICATOR DECAL	SEE FOOTNOTE 1
	274-940	2	INDICATOR DECAL	SEE FOOTNOTE 2
34	275-372	1	IMPORTANT CYLINDER LOCK	
35	273-227	1	SHUTTLE STOP INDICATOR	
36	273-198	1	TRACKER CONTROL	
37	273-233	1	FRONT WRENCH VALVE	
38	270-1086	1	4020 T3 ELECTRICAL BLOCK	
39	270-1087	1	4020 T3 ELECTRICAL BLOCK	
40	273-384	1	PIPELOADER VALVE	
41	273-278	1	DANGER WRENCH	
42	270-1120	1	AT/JT42T3 FUSE BLOCK (FRONT	
43	270-1131	1	AT/JT42T3 LED DISPLAY A	
44	270-1132	1	AT/JT42T3 LED DISPLAY B	
45	270-1119	1	AT/JT42T3 FUSE BLOCK (BACK	

FOOTNOTES

1. PART OF KIT NUMBER 270-1116
2. PART OF KIT NUMBER 270-1117
3. NOT PART OF KIT.
4. LOCATE DECAL ON BATTERY SO THAT DECAL IS VISIBLE WHEN VIEWING BATTERY .
5. USE 17"

ENGINE COMPONENTS

ENGINE

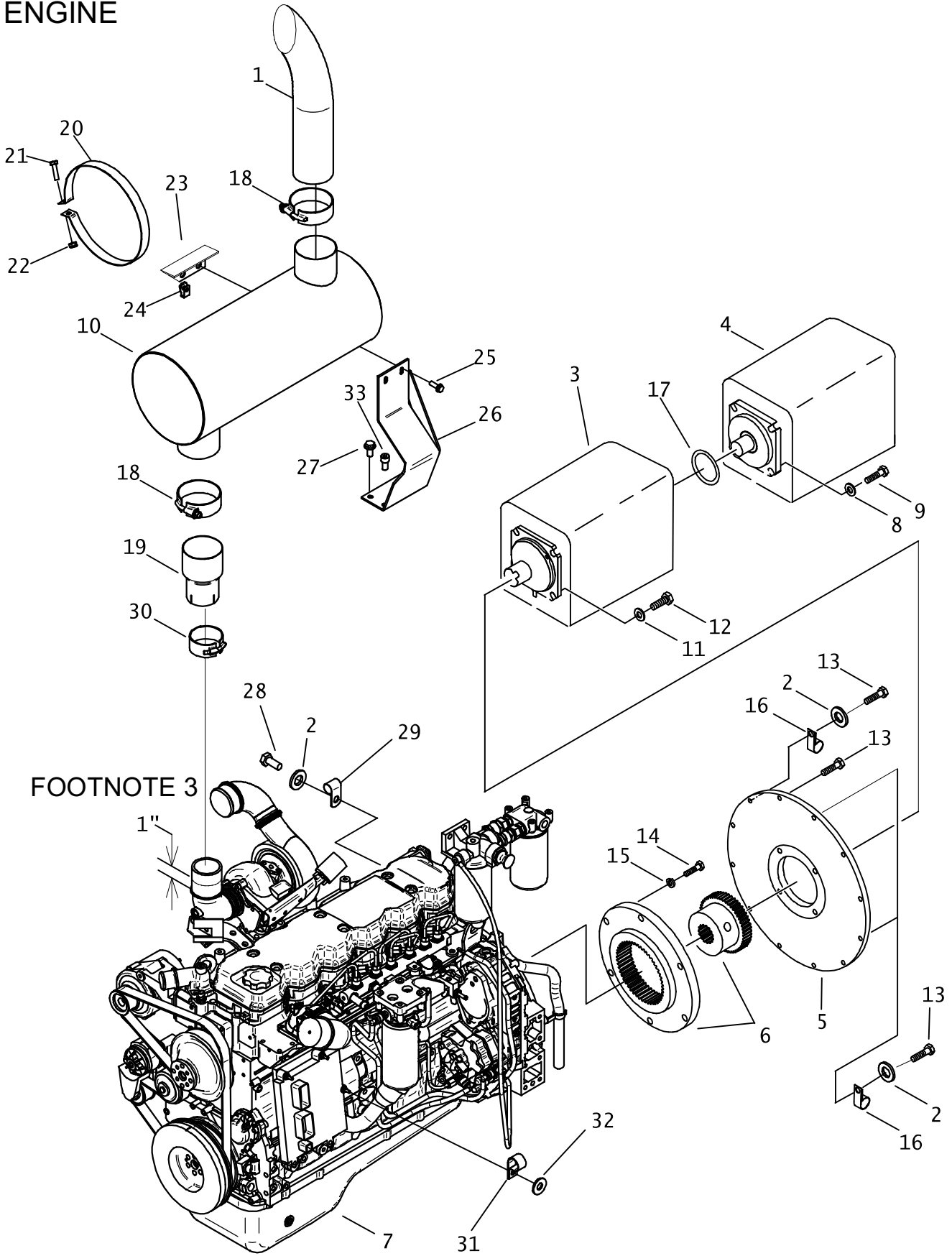

FOOTNOTE 3

1"

ENGINE

REF NO.	PART NUMBER	QTY	DESCRIPTION	REMARKS
1.	194-468	1	EXHAUST ELBOW (4" DIA.)	
2.	106-390	3	WASHER (M10)	
3.	153-340	1	HYDRAULIC PUMP	SEE FOOTNOTE 2
	149-939	1	FILTER ELEMENT	
4.	150-2180	1	HYDRAULIC PUMP LS	
	190-1371	-	PUMP SEAL KIT	
5.	336-051	1	FLY WHEEL HOUSING COVER	
6.	160-897	1	DRIVE COUPLING	SEE FOOTNOTE 1
7.	194-662	1	ENGINE-CUMMINS QSB6.7	
	500-1411	-	FUEL FILTER HEAD	
	195-1034	-	FILTER, ENGINE OIL	
	195-1035	-	FUEL FILTER (PRIMARY)	
	195-1036	-	FUEL FILTER (SECONDARY)	
	195-1074	-	OIL FILL CAP	
	195-1075	-	OIL DIP STICK	
	195-1076	-	BELT	
	195-1077	-	THERMOSTAT	
	195-1078	-	ALT	
8.	106-398	2	WASHER (M16, HARDENED)	
9.	105-456	2	BOLT (5/8-NC X 1-3/4", GD8)	LOCTITE 242
10.	195-1496	1	MUFFLER	
11.	105-244	4	WASHER (1/2")	
12.	105-048	4	BOLT (1/2-NC X 1-1/2")	USE 242 LOCTITE
13.	106-383	12	FLG LK SCREW (M10-1.50 X 30mm)	USE 242 LOCTITE
14.	105-156	8	BOLT (3/8-NC X 1-1/2")	USE 242 LOCTITE, TORQUE TO 30 FT LBS
15.	105-072	8	LOCK WASHER (3/8")	SEE FOOTNOTE 3
16.	110-333	3	BOLT-ON CLAMP (1")	
17.	157-084	-	O-RING (159 D70)	
18.	194-027	2	MUFFLER CLAMP	
19.	194-876	1	EXHAUST ADAPTER	
20.	300-2421	1	BAND	
21.	106-332	1	SCREW (M10-1.50 X 70mm)	
22.	106-758	1	LK NUT (M10-1.5)	
23.	300-2450	1	SUPPORT BRACKET	
24.	106-558	2	CLIP NUT (M10-1.5)	
25.	106-164	2	FLG SCREW (M10-1.50 X 30mm)	
26.	300-2409	1	SUPPORT	
27.	106-382	2	FLG SCREW (M10-1.50 X 20mm)	
28.	105-245	1	SCREW (M10-1.50 X 25mm)	
29.	110-333	1	BOLT-ON CLAMP (1")	
30.	194-049	1	CLAMP ASSEMBLY	
31.	110-373	1	BOLT-ON CLAMP (13/16")	
32.	105-095	1	WASHER (1/4")	
33.	106-080	2	SCREW (M10*1.50 X 20MM, SOC)	

FOOTNOTES:

- TORQUE CROSSBOLT TO 85-90 FT LB, MOUNT FLUSH WITH END OF SHAFT
- ON THE BACK OF THE PUMP OF SOME EARLY MACHINES A DIFFERENT MOUNT PAD WAS USED. IF THE BOLTS HOLDING THE PAD TO THE PUMP HAVE A WASHER UNDER THE BOLT HEAD USE O-RING 157-201 BETWEEN THE PUMPS.
- SET ADAPTER 1.0" FROM 90° BEND IN ELBOW

NOTE:

REFER TO O-RING CHART (800-301) IN BACK OF THE BOOK FOR REPLACEMENT OF O-RINGS.

FAN DRIVE

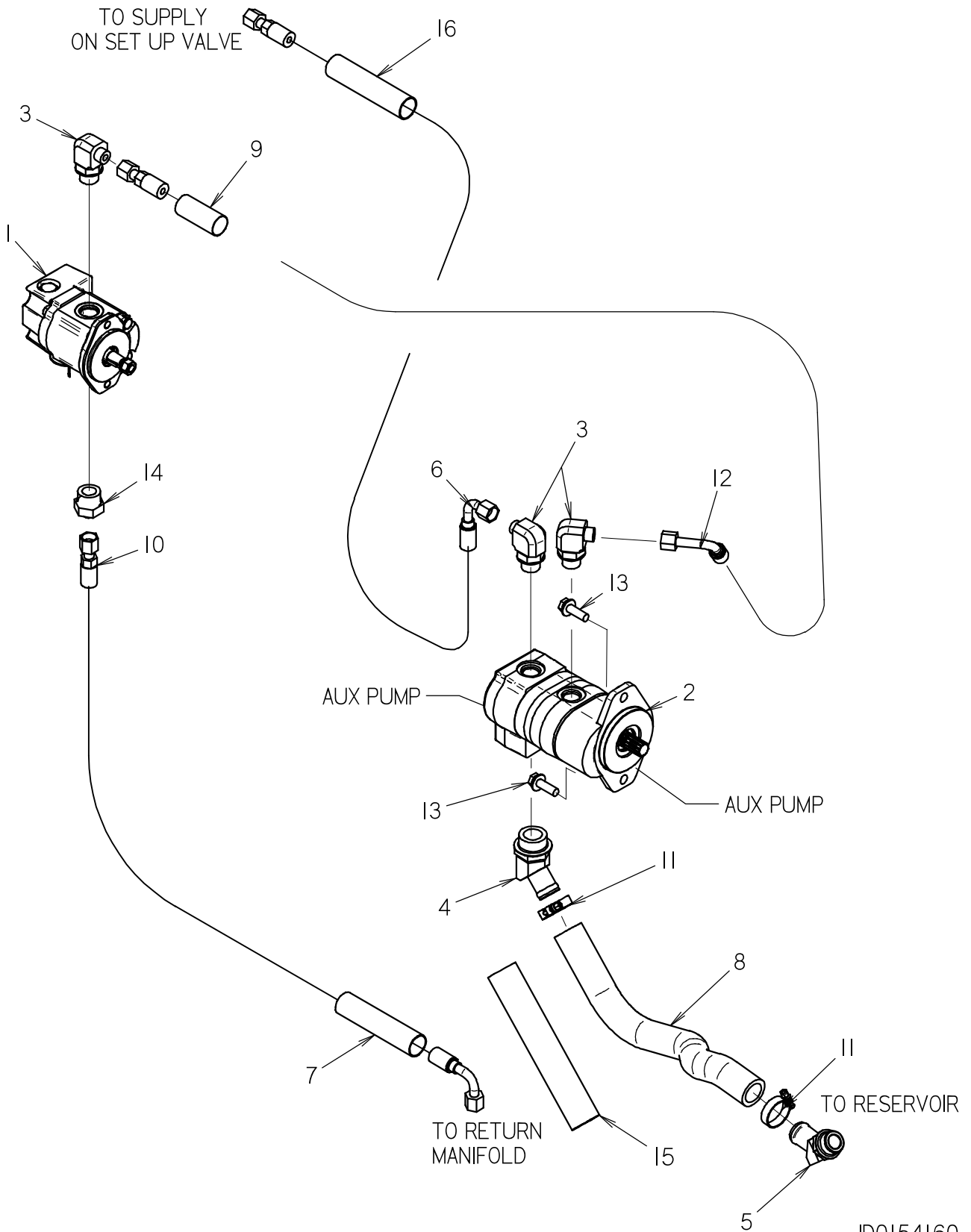

FAN DRIVE

REF NO.	PART NUMBER	QTY	DESCRIPTION	REMARKS
1	I50-I05I	1	HYDRAULIC MOTOR	SEE FOOTNOTE I
2	I52-I63	1	TANDEM PUMP	
3	I54-236	3	CONNECTOR (080-I2S90)	
4	514-426	1	ELBOW (20S-20H45)	
5	115-281	1	SO COUPLER (16S-20H45)	
6	515-550	1	HOSE (080FX90-98"-3000)	
7	117-211	1	ABRASION SLEEVE (1.25" X 90")	
8	116-587	1	BULK HOSE (1-1/4",SOLD PER FT)	USE I @ 56"
9	117-389	1	ABRASION SLEEVE (1.25" X 104")	
10	I54-877	1	HOSE (080FX90-90"-3000)	
11	I49-342	2	T-BOLT CLAMP (1.687")	
12	I50-I344	1	HOSE (080FXL-I08"-3000)	
13	I06-632	2	FLG LK SCR (M12-1.75X35MM,SER)	USE LOCTITE 242
14	I54-307	1	CONNECTOR (16S-080)	
15	117-669	1	ABRASION SLEEVE (1.75" X 55")	
16	117-210	1	ABRASION SLEEVE (1.25" X 100")	

NOT SHOWN:

FOOTNOTES:

- I. SERVICE PARTS FOR I50-I05I:
- 500-I316 - SEAL SERVICE KIT
 - 500-I317 - SOLENOID
 - 500-I318 - PROP, RELIEF VALVE
 - 500-I319 - SPEED SENSOR ASSEMBLY

NOTE:

FAN & SHROUD ASSEMBLY

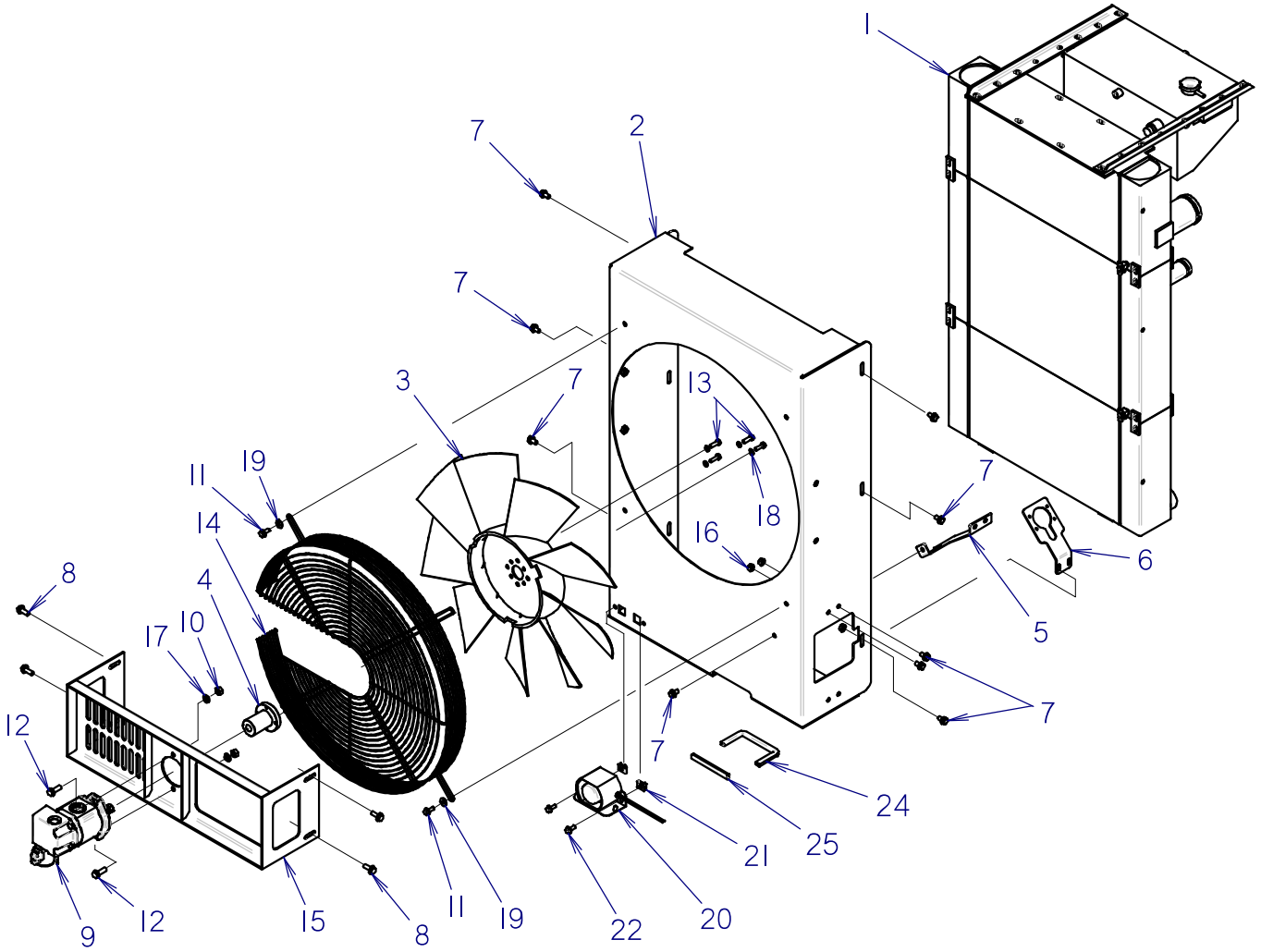

FAN & SHROUD ASSEMBLY

REF NO.	PART NUMBER	QTY	DESCRIPTION	REMARKS
1	195-1004	1	CAC/RAD/HOC	
2	300-1124	1	FAN SHROUD ASSEMBLY	
3	194-134	1	FAN (26.0" OD, 2.50" BC)	
4	194-1000	1	FAN HUB	
5	300-1418	1	ACCESS SHIELD	
6	364-487	1	FUEL FILL BRACKET	
7	501-153	9	FLG LK BOLT (3/8-NC X 5/8")	
8	106-724	4	FLG SCREW (M10-1.50 X 25MM)	
9	150-1051	1	HYDRAULIC MOTOR	
10	105-894	2	LOCKNUT (M10-1.50, PRV TRQ, 10.9)	
11	106-162	4	FLG SCREW (M8-1.25 X 20MM, GD8)	
12	106-383	2	FLG LK SCREW (M10-1.50 X 30MM)	
13	105-806	4	SCREW (M8-1.25 X 25MM)	TORQUE TO 20 FT/LBS
14	195-1049	1	FAN GUARD (27")	
15	300-1119	1	FAN MOTOR MOUNT ASSEMBLY	
16	105-834	3	FLG LOCKNUT (3/8-NC)	
17	106-396	2	WASHER (M10, HARDENED)	
18	105-091	4	LOCK WASHER (5/16")	
19	105-117	4	WASHER (5/16")	
20	306-602	1	ALARM	SEE FOOTNOTE 1
21	106-551	2	CLIP NUT (M8-1.25)	
22	106-991	2	FLG LK SCREW (M8-1.25 X 20MM)	
24	115-686	AR	BULK EDGE (5/32", SOLD PER 1")	USE 1 @ 5"
25	115-686	1	BULK EDGE (5/32", SOLD PER 1")	USE 1 @ 10"

NOT SHOWN:

FOOTNOTES:

- | | | |
|------------|---|------------------------|
| I. 214-104 | 1 | PACKARD MALE TERMINAL |
| 214-103 | 2 | (2-WAY) MALE CONNECTOR |
| 157-645 | 2 | WEATHER-PAC SEAL |

NOTE:

ENGINE MOUNTS

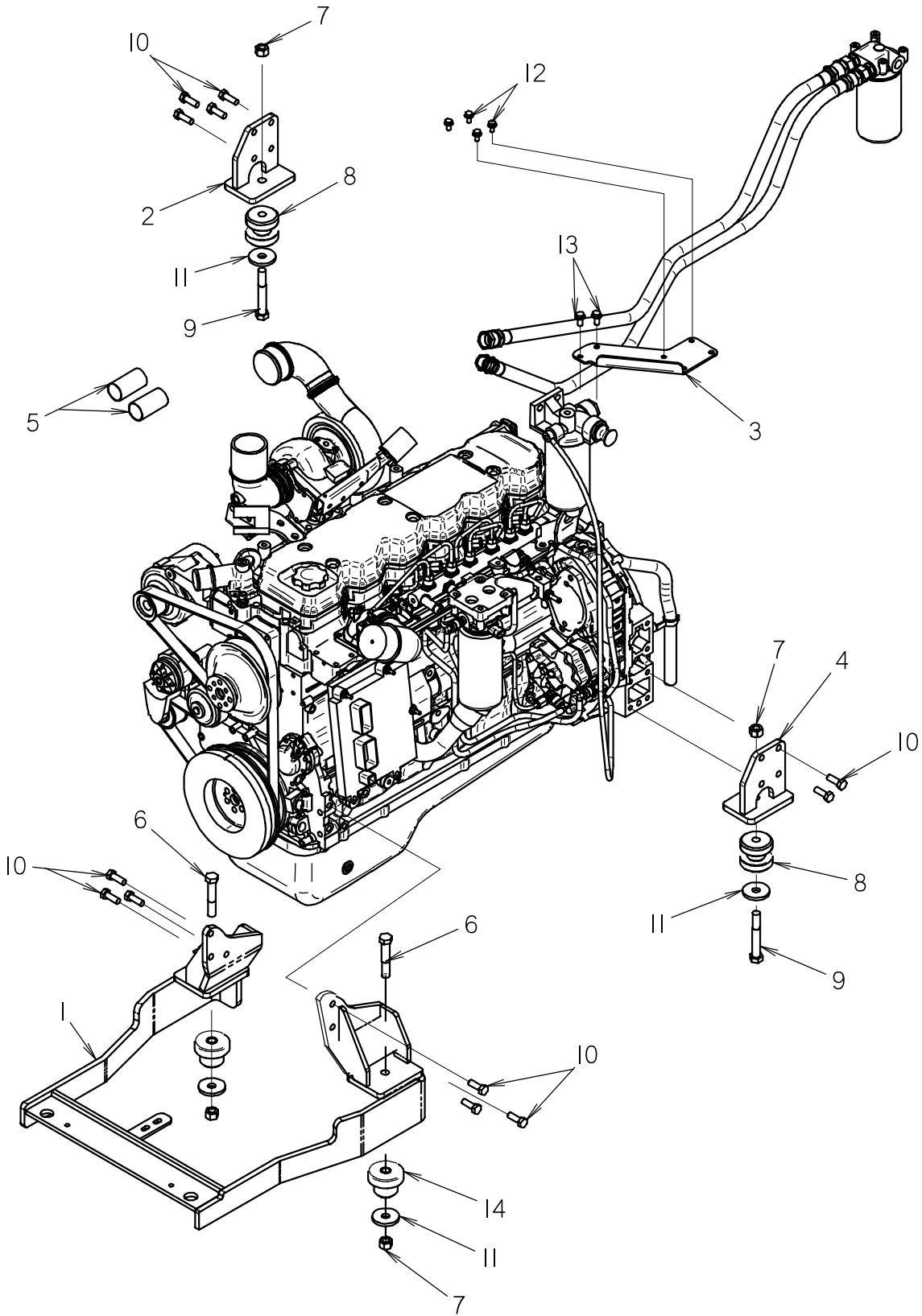

ENGINE MOUNTS

REF NO.	PART NUMBER	QTY	DESCRIPTION	REMARKS
1	327-383	1	FRONT ENGINE MOUNT	
2	327-381	1	ENGINE MOUNT, RIGHT REAR	
3	300-1568	1	FILTER BRACKET	
4	327-380	1	ENGINE MOUNT, LEFT REAR	
5	117-720	2	ABRASION SLEEVE (1.59" X .48")	
6	106-342	2	SCREW (M16-2.00 X 90MM)	
7	106-545	4	LOCKNUT (M16-2.0.PRV TRQ,10.9)	
8	116-127	2	H-MOUNT ISOLATOR 116-127	
9	106-343	2	SCREW (M16-2.00 X 110MM)	
10	105-247	14	SCREW (M12-1.75 X 35MM)	USE LOCTITE 242
11	105-416	4	WASHER (5/8")	
12	106-380	4	FLG LK SCREW (M8-1.25 X 16MM)	
13	106-382	2	FLG LK SCREW (M10-1.50 X 20MM)	
14	116-726	2	T-mount , Rubber Isolator	

NOT SHOWN:

FOOTNOTES:

NOTE:

ENGINE SKID

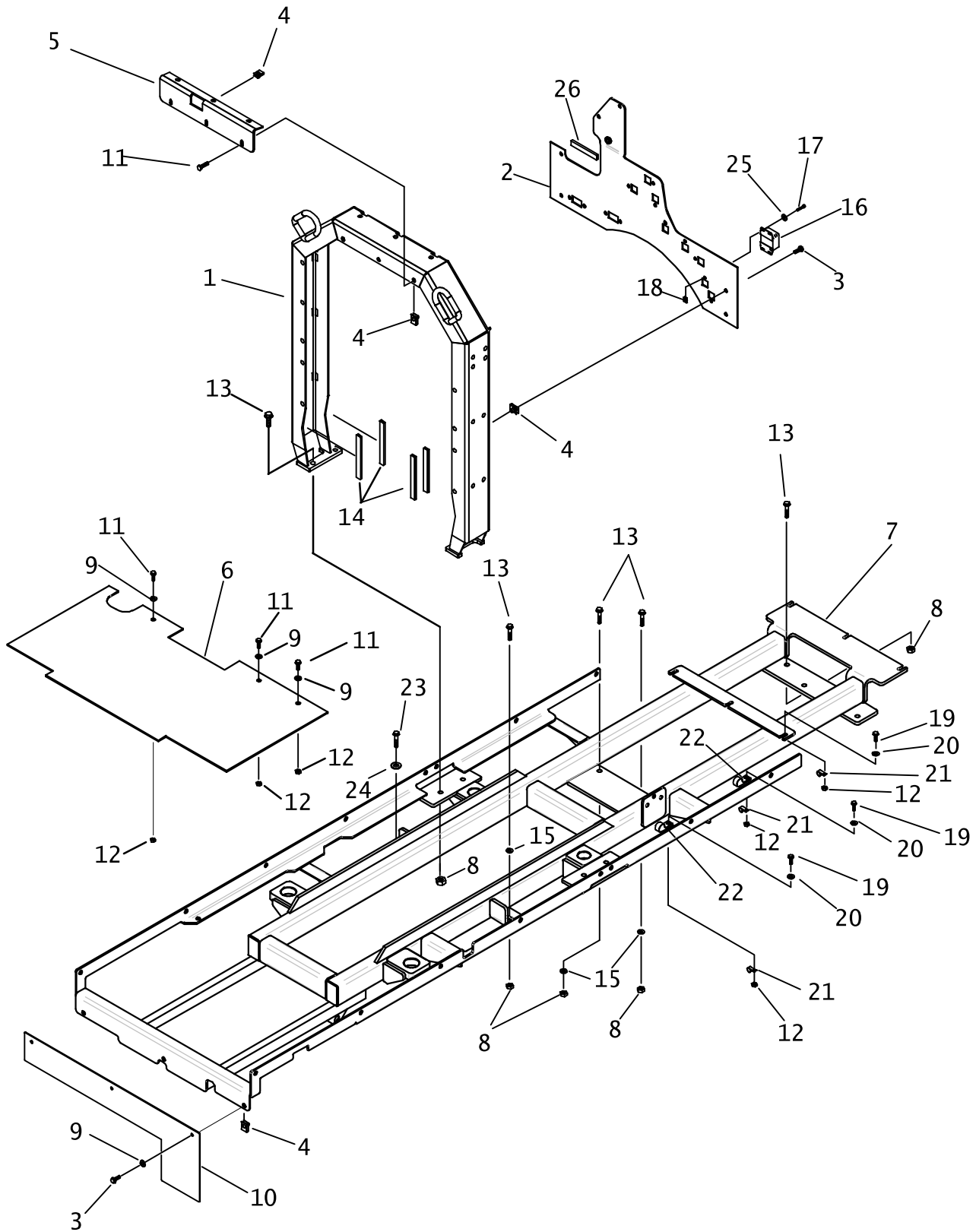

ENGINE SKID

REF NO.	PART NUMBER	QTY	DESCRIPTION	REMARKS
1.	322-482	1	SKID LIFT	
2.	300-1762	-	FIREWALL	
3.	106-991	10	FLG LK SCREW (M8-1.25 X 20mm)	
4.	106-551	48	CLIP NUT (M8-1.25)	
5.	323-620	1	HOOD SUPPORT	
6.	105-1063	1	AIR BARRIER	
7.	300-1563	1	ENGINE SKID	
8.	106-685	12	LOCKNUT (M12-1.75, PRV TRQ, 10.9)	
9.	105-118	9	WASHER (3/8")	
10.	350-410	1	DEFLECTOR FLAP	
11.	106-162	5	FLG SCREW (M8-1.25 X 20mm, GD 8)	
12.	106-561	5	LOCKNUT (M8-1.25, PRV TRQ, 10.9)	
13.	106-632	12	FLG LK SCR (M12-1.75 X 35MM, SER)	
14.	115-686	AR	BULK EDGE (5/32", SOLD PER 1")	USE 4 @ 7.0"
15.	106-391	4	WASHER (M12)	USED ON SLOTTED HOLES
16.	211-017	1	12V-5V VOLTAGE CONVERTOR	
17.	107-268	2	SCREW (M4-0.70 X 20MM, SOC)	
18.	107-516	2	CLIP NUT (M4-.7)	
19.	106-381	5	FLG LK SCREW (M8-1.25 X 25MM)	
20.	106-390	5	WASHER (M10)	
21.	110-333	3	BOLT-ON CLAMP (1")	
22.	110-126	2	BOLT-ON CLAMP (1/2")	
23.	105-743	1	FLG LK SCREW (M12-2.00 X 45mm)	
24.	106-397	1	WASHER (M12, HARDENED)	
25.	106-205	2	WASHER (.191")	
26.	115-686	AR	BULK EDGING (5/32", SOLD PER 1")	

NOT SHOWN:

FOOTNOTES:

NOTE:

ENGINE SKID EDGING

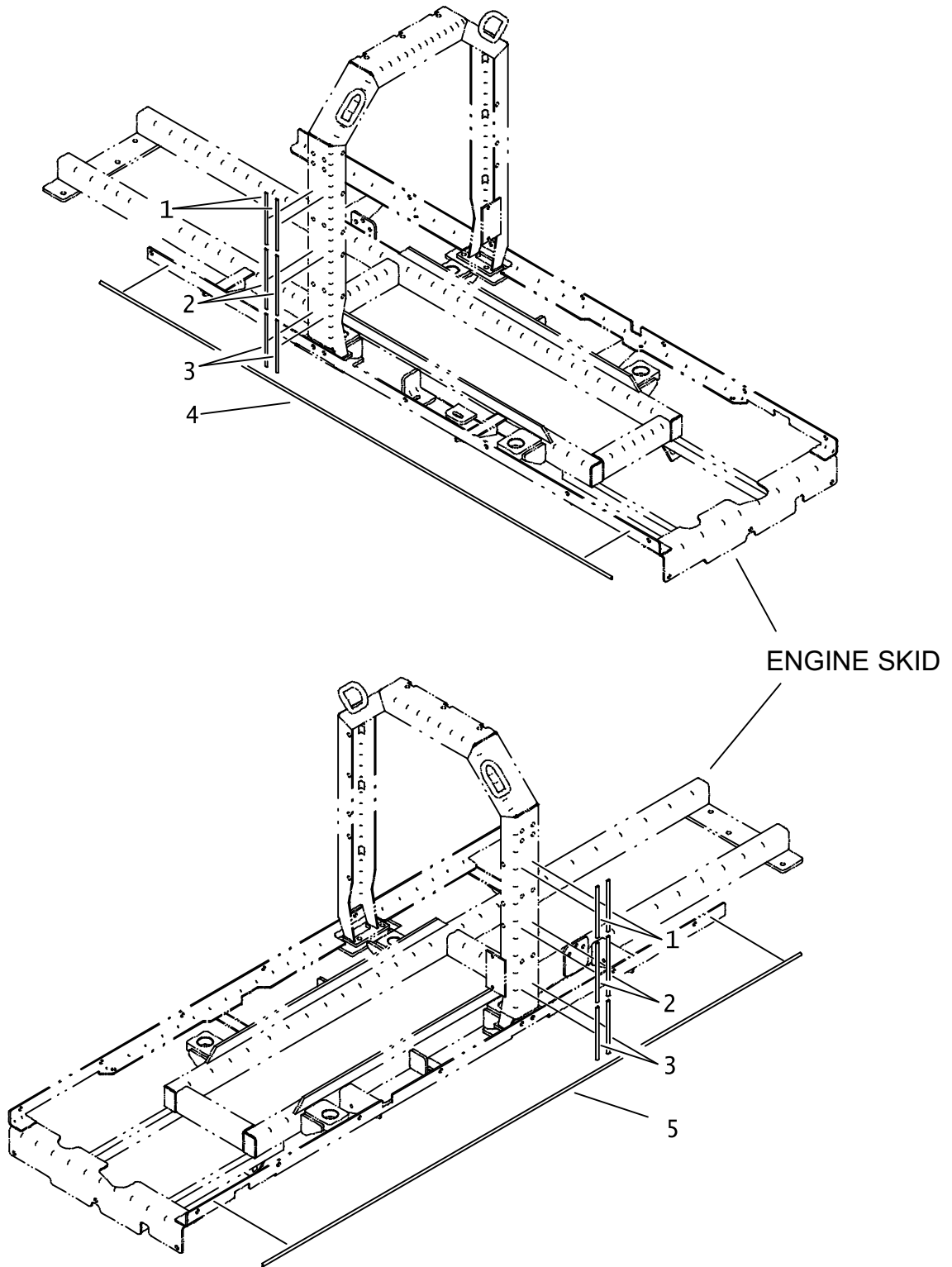

ENGINE SKID EDGING

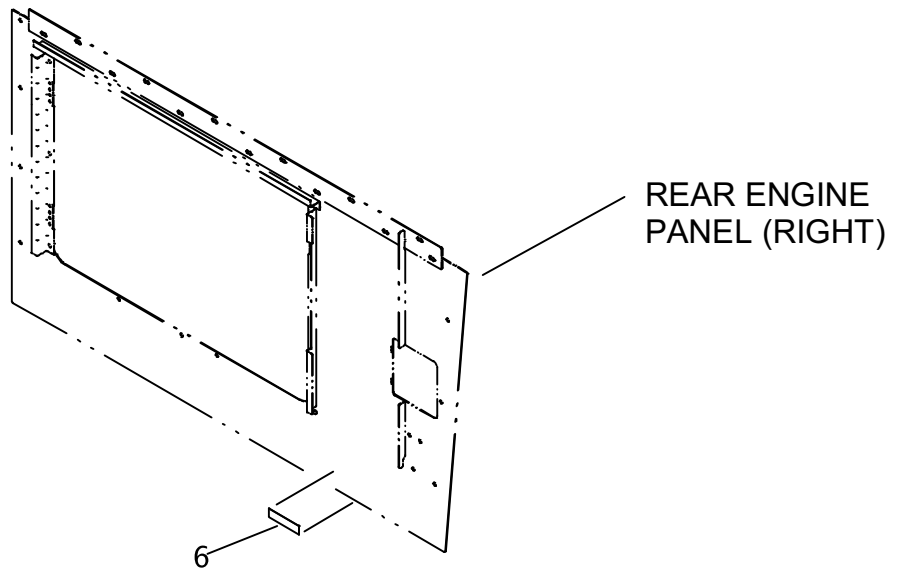
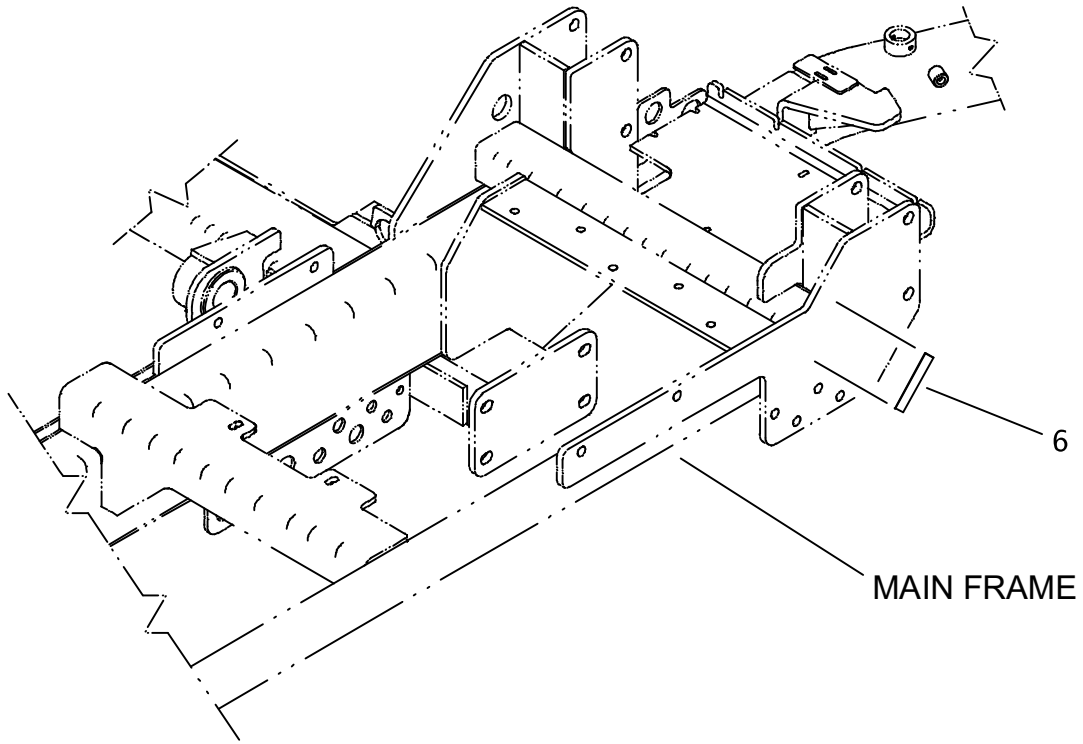

ENGINE SKID EDGING

REF NO.	PART NUMBER	QTY	DESCRIPTION	REMARKS
1.	116-724	AR	BULK SEAL (3/32", SOLD PER 1')	USE 4 @ 7.2"
2.	116-724	AR	BULK SEAL (3/32", SOLD PER 1')	USE 4 @ 8.4"
3.	116-724	AR	BULK SEAL (3/32", SOLD PER 1')	USE 4 @ 7.4"
4.	116-724	AR	BULK SEAL (3/32", SOLD PER 1')	USE 1 @ 83.8"
5.	116-724	AR	BULK SEAL (3/32", SOLD PER 1')	USE 1 @ 88.2"
6.	391-322	AR	.040 X 1.0" UHMW-PE ADHES BACK	USE 8 @ 4"

NOT SHOWN:

FOOTNOTES:

NOTE:

ENGINE OIL DRAIN

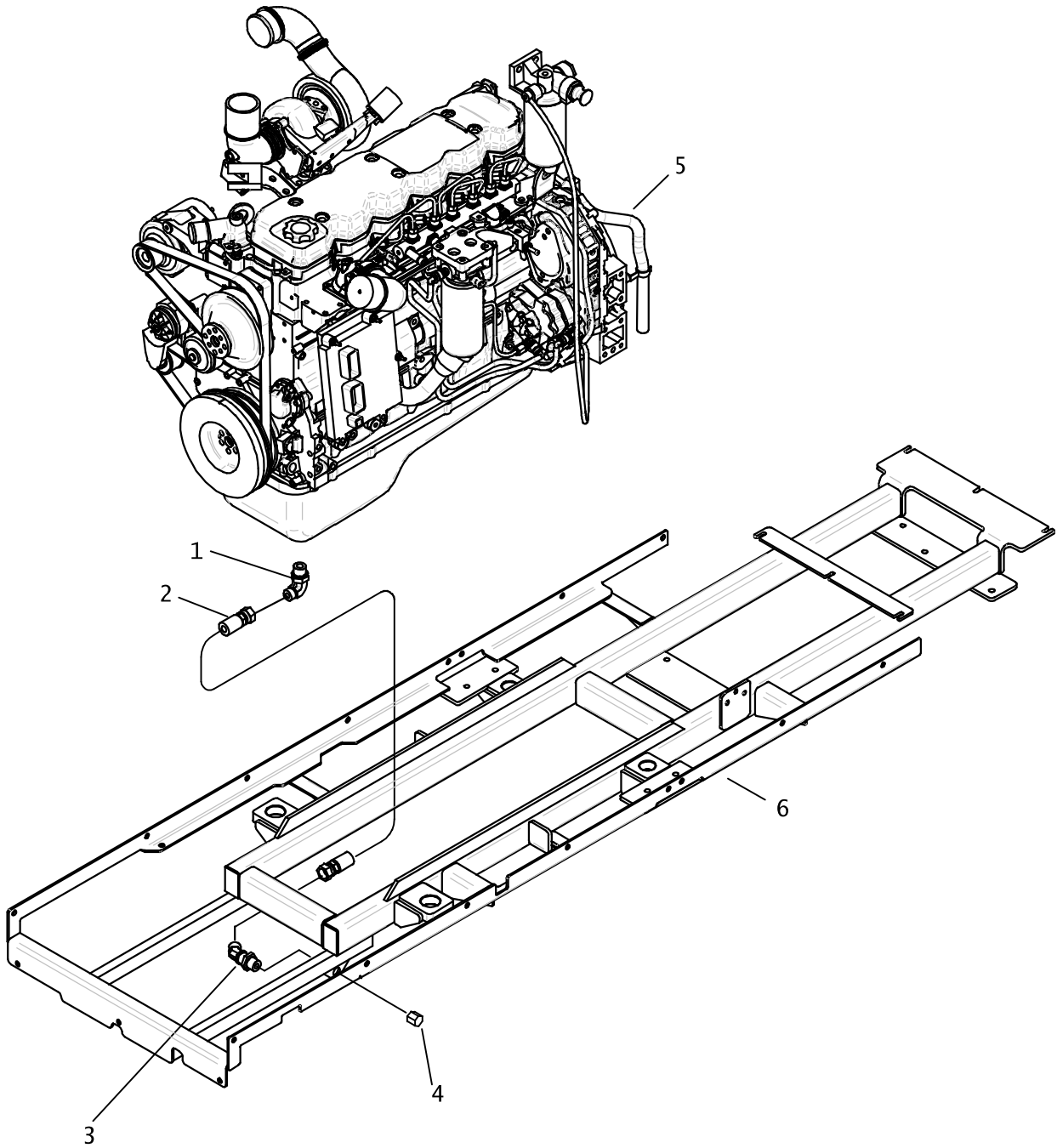

ENGINE OIL DRAIN

REF NO.	PART NUMBER	QTY	DESCRIPTION	REMARKS
1.	153-166	1	CONNECTOR (M18-1.50-08J90)	
2.	150-1261	1	HOSE (08JFX-8.5"-2000)	
3.	154-393	1	BK CONNECTOR (08J-08J90BK)	
4.	154-327	1	CAP (080F)	
5.	194-662	-	ENGINE, CUMMINS QSB6.7	
6.	300-1563	-	ENGINE SKID	

NOT SHOWN:

FOOTNOTES:

NOTE:

REFER TO O-RING CHART (800-301) IN BACK OF THE BOOK FOR REPLACEMENT OF O-RINGS.

AIR FILTER SYSTEM

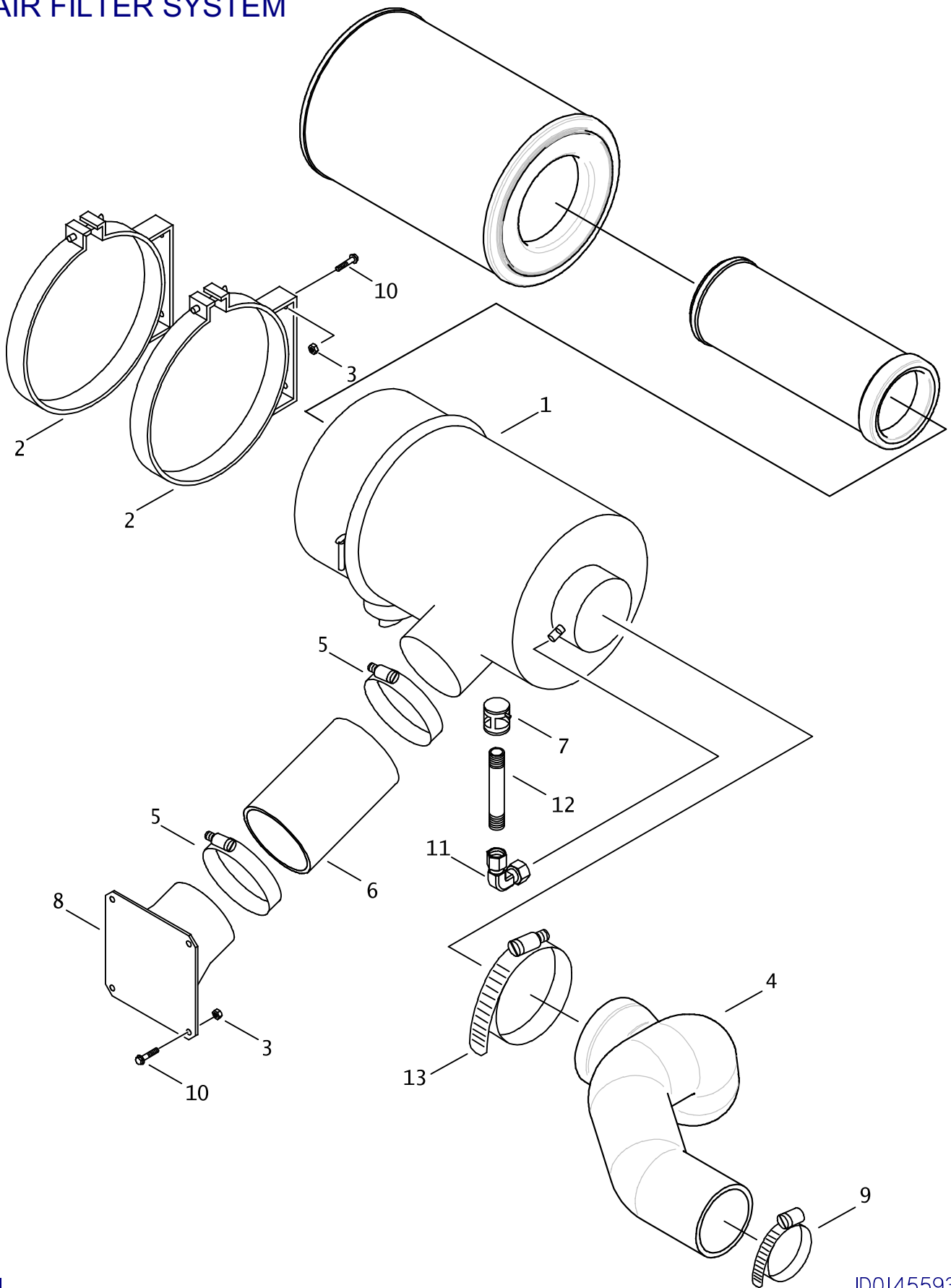

AIR FILTER SYSTEM

REF NO.	PART NUMBER	QTY	DESCRIPTION	REMARKS
1.	194-672	1	ENGINE AIR CLEANER	
			AIR CLEANER ELEMENT(REPLACEMENT FILTERS)	
	500-1086	1	PRIMARY AIR FILTER	
	500-1087	1	SAFETY AIR FILTER	
2.	194-673	2	MOUNTING BAND (13")	
3.	106-561	8	LOCKNUT (M8-1.25, PRV TRQ, 10.9)	
4.	118-485	1	HOSE - AIR FILTER	
5.	195-757	3	WORM CLAMP (? TO 8-1/2")	
6.	105-1075	1	FLEX HOSE (6" I.D. X 12" LG)	
7.	194-788	1	RESTRICTION INDICATOR (25", H2O)	
8.	327-379	1	INTAKE	
9.	110-170	1	WORM CLAMP (4-1/8" TO 5")	
10.	106-162	8	FLG SCREW (M8-1.25 X 20MM)	
11.	156-228	1	ELBOW (02NF-02NF90)	
12.	115-188	1	NIPPLE (02N-4.250")	
13.	110-391	1	WORM CLAMP (4-3/4" TO 5-5/8")	

NOT SHOWN:

FOOTNOTES:

NOTE:

RADIATOR

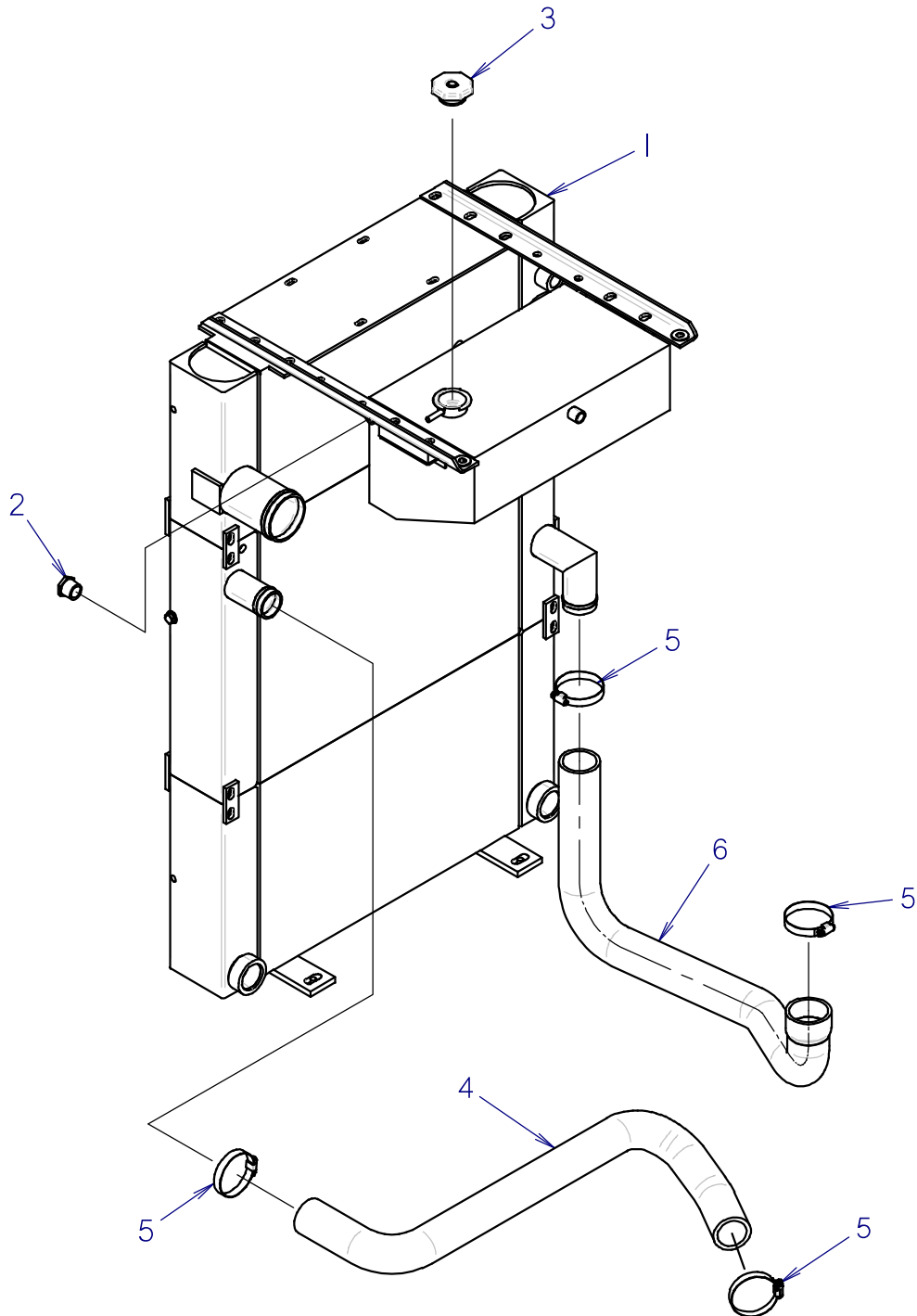

RADIATOR

REF NO.	PART NUMBER	QTY	DESCRIPTION	REMARKS
1	195-1004	1	CAC/RAD/HOC	SEE FOOTNOTE 1 FOR SERVICE PARTS
2	110-549	1	SIGHT GAUGE (12N)	
3	111-084	1	RADIATOR CAP (16 PSI)	INCLUDED WITH RADIATOR
4	118-484	1	HOSE, COOLANT OUTLET	
5	110-134	4	WORM CLAMP (2.062" TO 2.750")	INCLUDED WITH RADIATOR
6	118-483	1	HOSE - COOLANT INLET	

NOT SHOWN:

FOOTNOTES:

1. 195-1238 SURGE TANK

NOTE:

RADIATOR MOUNT

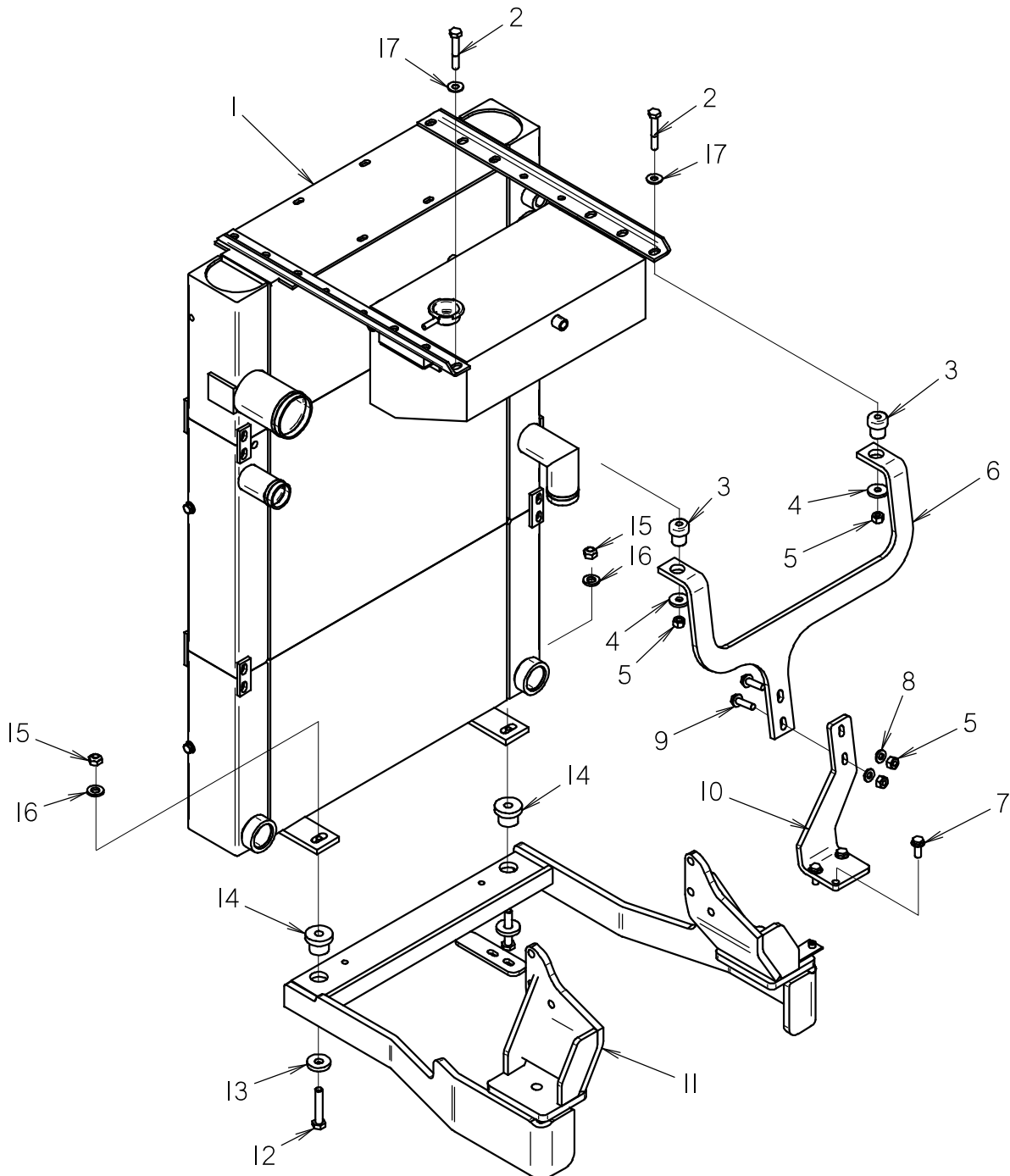

RADIATOR MOUNT

REF NO.	PART NUMBER	QTY	DESCRIPTION	REMARKS
1	195-1004	1	CAC/RAD/HOC	
2	106-142	2	SCREW (M10-1.50 X 65MM)	
3	117-906	2	SHOCK MOUNT (70D)	
4	106-622	2	WASHER (3/8")	
5	105-894	4	LOCKNUT(M10-1.50,PRV TRQ,10.9)	
6	300-1263	1	TOP RADIATOR SUPPORT	
7	106-724	3	FLG SCREW (M10-1.50 X 25MM)	
8	106-396	2	WASHER (M10, HARDENED)	
9	107-111	2	FLG SCREW (M10-1.50 X 35MM)	
10	327-516	1	LOWER RADIATOR BRACKET	
11	327-383	1	FRONT ENGINE MOUNT	
12	107-507	2	SCREW (M12-1.75 X 65MM)	
13	105-398	2	WASHER (1/2")	
14	317-032	2	GROMMET (1-1/8", T-MOUNT)	
15	106-685	2	LOCKNUT(M12-1.75,PRV TRQ,10.9)	
16	106-397	2	WASHER (M12, HARDENED)	
17	105-118	2	WASHER (3/8")	

NOT SHOWN:

FOOTNOTES:

NOTE:

CHARGE AIR

JT4020 T3

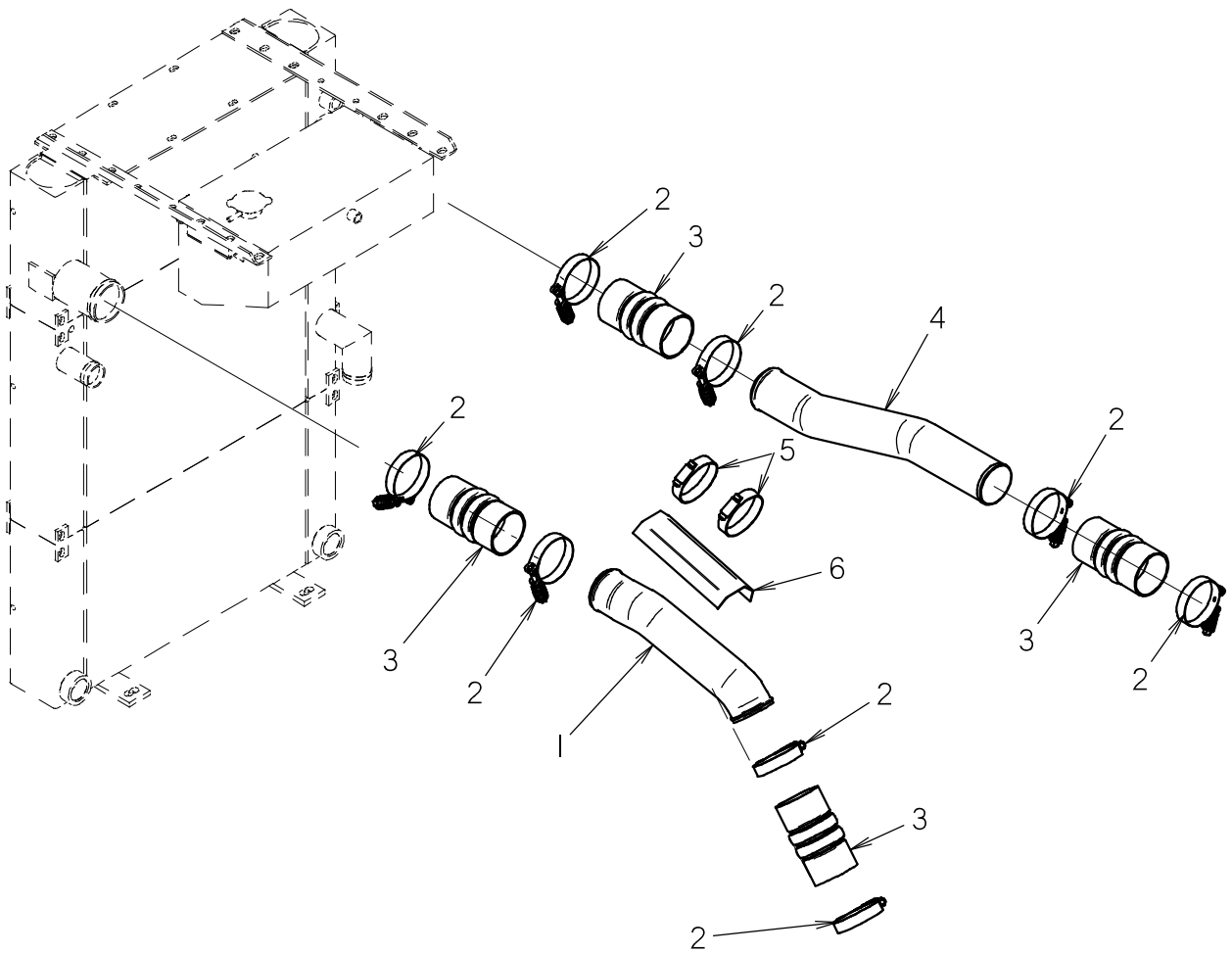

CHARGE AIR

JT4020 T3

REF NO.	PART NUMBER	QTY	DESCRIPTION	REMARKS
1	152-166	1	TUBE - CHARGE AIR INLET	
2	118-490	8	T-BOLT CLAMP (3.06" TO 3.30")	
3	116-703	4	CHARGE AIR COOLER HOSE	
4	152-167	1	TUBE, CHARGE AIR- OUTLET	
5	110-311	2	WORM CLAMP (1-5/16" TO 3-1/4")	
6	300-2201	1	COVER PLATE WELDMENT	

NOT SHOWN:

FOOTNOTES:

NOTE:

DEAREATION JT4020 T3

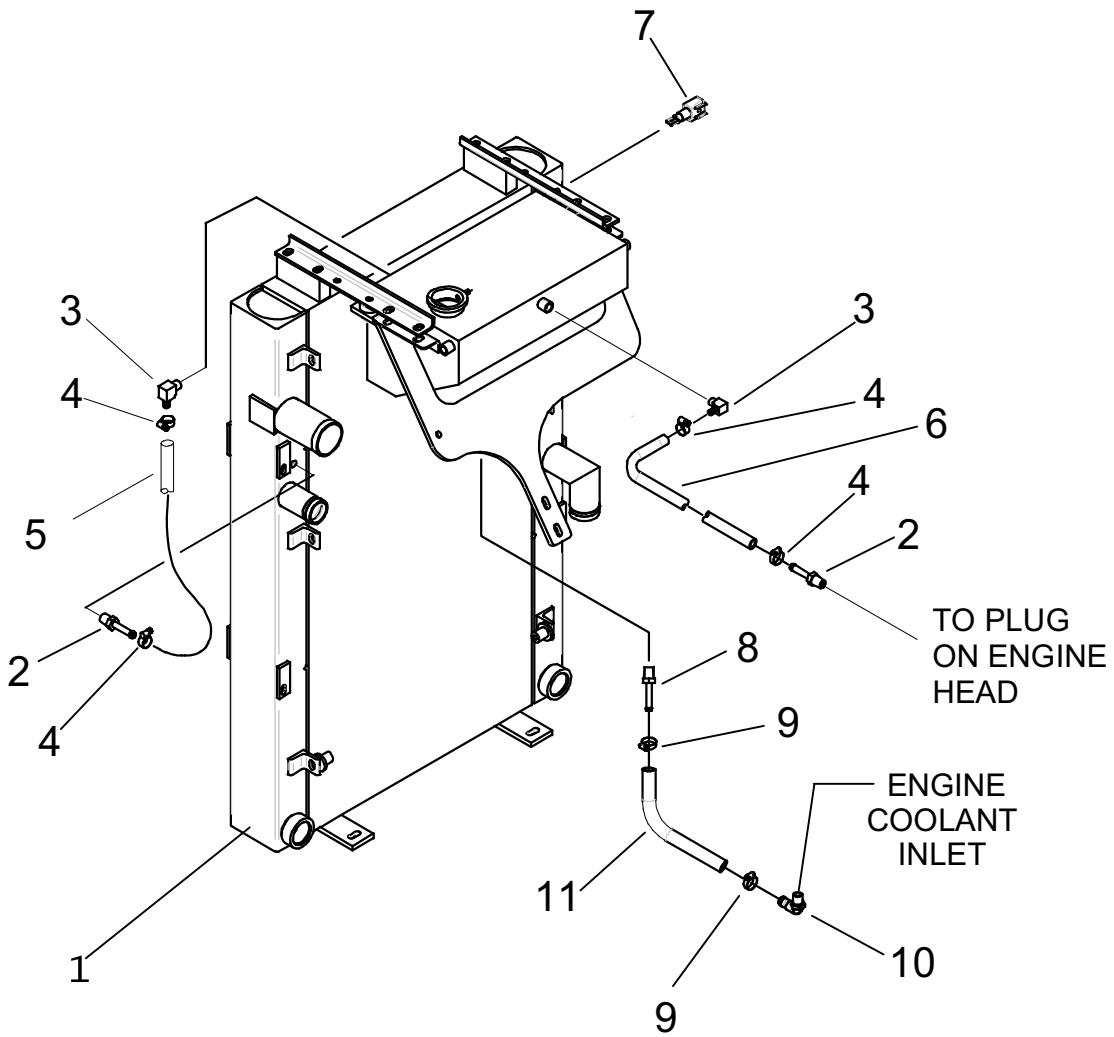

DEAREATION

JT4020 T3

REF NO.	PART NUMBER	QTY	DESCRIPTION	REMARKS
1.	195-1004	-	RADIATOR	
2.	155-162	2	S/O COUPLER (04N-05H)	USE 567 LOCTITE
3.	155-164	2	S/O COUPLER (04N-05H90)	USE 567 LOCTITE
4.	110-249	4	WORM CLAMP (1/4" TO 5/8")	
5.	116-108	AR	BULK HOSE (5/16", SOLD PER 1")	USE 1 @ 16"
6.	116-108	AR	BULK HOSE (5/16", SOLD PER 1")	USE 1 @ 29"
7.	213-366	1	COOLENT LEVEL SWITCH	USE 567 LOCTITE
8.	155-136	1	S/O COUPLER (16N-16H)	USE 567 LOCTITE
9.	110-353	2	WORM CLAMPS (3/4" TO 1-1/2")	
10.	150-1333	1	S/O COUPLER (12N-16H90)	USE 567 LOCTITE
11.	116-094	AR	BULK HOSE (1" SOLD PER 1")	USE 1 @ 36"

NOT SHOWN:

FOOTNOTES:

NOTE:

ENGINE COVERS

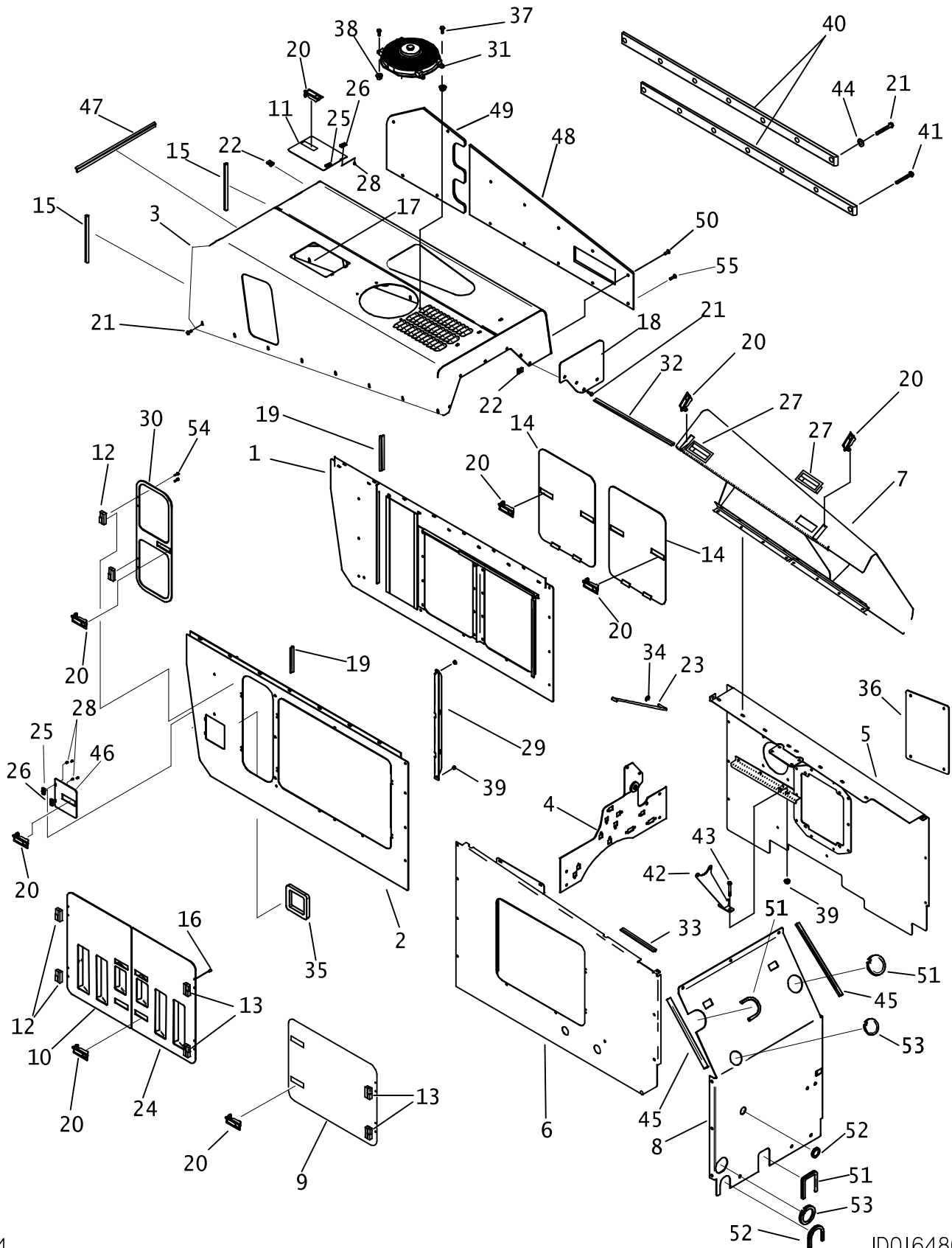

ENGINE COVERS

REF NO.	PART NUMBER	QTY	DESCRIPTION	REMARKS
1.	329-884	1	REAR ENGINE PANEL (LEFT)	
2.	329-885	1	REAR ENGINE PANEL (RIGHT)	
3.	329-886	1	ENGINE PANEL (TOP)	
4.	300-1763	1	FIRE WALL	
5.	310-452	1	FRONT ENGINE PANEL (LEFT)	
6.	310-448	1	FRONT ENGINE PANEL (RIGHT)	
7.	350-611	1	FRONT HOOD	
8.	300-1311	1	AIR BARRIER	
9.	354-579	1	DOOR PANEL	
10.	300-1905	1	LEFT DOOR	
11.	354-875	1	DOOR PANEL	
12.	111-002	4	LIFT-OFF HINGE (OFF-SET)	
13.	105-617	4	LIFT-OFF HINGE (OFF-SET)	
14.	300-1265	2	LEFT DOOR	
15.	116-421	AR	BULK EDGE (1/8",SOLD PER 1 FT)	USE 2 @ 12"
16.	106-228	28	SCREW (M5-.80 X 10mm)	
17.	116-489	AR	BULK EDGE (1/8",SOLD PER 1')	USE 1 @ 35.5"
18.	300-2704	1	END PLATE	
19.	116-421	AR	BULK EDGE (1/8",SOLD PER 1')	USE 2 @ 27.5"
20.	117-558	15	ADJUST LEVER LATCH (LOCKING)	
	214-961		KEY, PAIR (BASE CODE)	
	217-309		LOCK PLUG 4/LATCH (BASE CODE)	
21.	106-991	81	FLG LOCK SCREW (M8-1.25 X 20mm)	
22.	106-551	71	CLIP NUT (M8-1.25)	
23.	354-884	1	PROP BAR	
24.	300-1904	1	RIGHT DOOR WELDMENT	
25.	111-051	2	HINGE	
26.	111-052	2	HINGE	
27.	110-989	2	POCKET PULL	
28.	105-650	16	SCREW (M4-.70 X 10mm)	
29.	300-2556	1	BACKUP BAR	

NOT SHOWN:

FOOTNOTES:

NOTE:

ENGINE COVERS

REF NO.	PART NUMBER	QTY	DESCRIPTION	REMARKS
30.	329-880	1	DOOR ASSEMBLY	
31.	215-205	1	FAN, OIL COOLER	
32.	115-686	AR	BULK EDGE (5/32", SOLD PER 1")	USE 1 @ 35.5"
33.	115-686	AR	BULK EDGE (5/32", SOLD PER 1")	USE 1 @ 8.0"
34.	115-477	1	GRIP RING (.375")	
35.	105-1070	1	DOOR SEAL	
36.	308-718	1	DOOR	
37.	106-379	4	FLG LK SCREW (M6-1.00 X 20mm)	
38.	106-237	4	LOCKNUT (M6-1.00, PRV TRQ, NLK)	
39.	106-386	4	FLG LOCKNUT (M8-1.25)	
40.	318-791	2	WEAR STRIP	SEE FOOTNOTE 1
41.	106-992	7	FLG LK SCREW (M8-1.25 X 25MM)	SEE FOOTNOTE 1
42.	318-481	-	SUPPORT	
43.	106-162	2	FLG SCREW(M8-1.25 X 20MM, GD8)	
44.	105-117	14	WASHER (5/16")	SEE FOOTNOTE 1
45.	116-421	AR	BULK EDGE (1/8", SOLD PER FT.)	USE 2 @ 20"
46.	354-581	1	DOOR PANEL	
47.	116-421	AR	BULK EDGE (1/8", SOLD PER FT.)	USE 1 @ 28"
48.	327-1081	1	WEAR PLATE	SEE FOOTNOTE 2
49.	327-1080	1	WEAR PLATE	SEE FOOTNOTE 2
50.	106-916	7	SCREW(M8-1.25 X 25MM,CSK,SOC)	SEE FOOTNOTE 2
51.	116-489	AR	BULK EDGE (1/8", SOLD PER FT.)	USE 3 @ 11"
52.	116-489	AR	BULK EDGE (1/8", SOLD PER FT.)	USE 2 @ 6.5"
53.	116-489	AR	BULK EDGE (1/8", SOLD PER FT.)	USE 2 @ 9"
54.	106-430	4	FLG SCREW(#12-14 X 3/4", SLF-TAP)	
55.	106-1002	7	SCREW(M8-1.25 X 30MM,CSK,SOC)	SEE FOOTNOTE 2

NOT SHOWN:

FOOTNOTES:

1. USE ON 4020 WITH OUT RACK AND PINION
2. USE ON 4020 WITH RACK AND PINION

NOTE:

SOUND INSULATION ENGINE COVERS

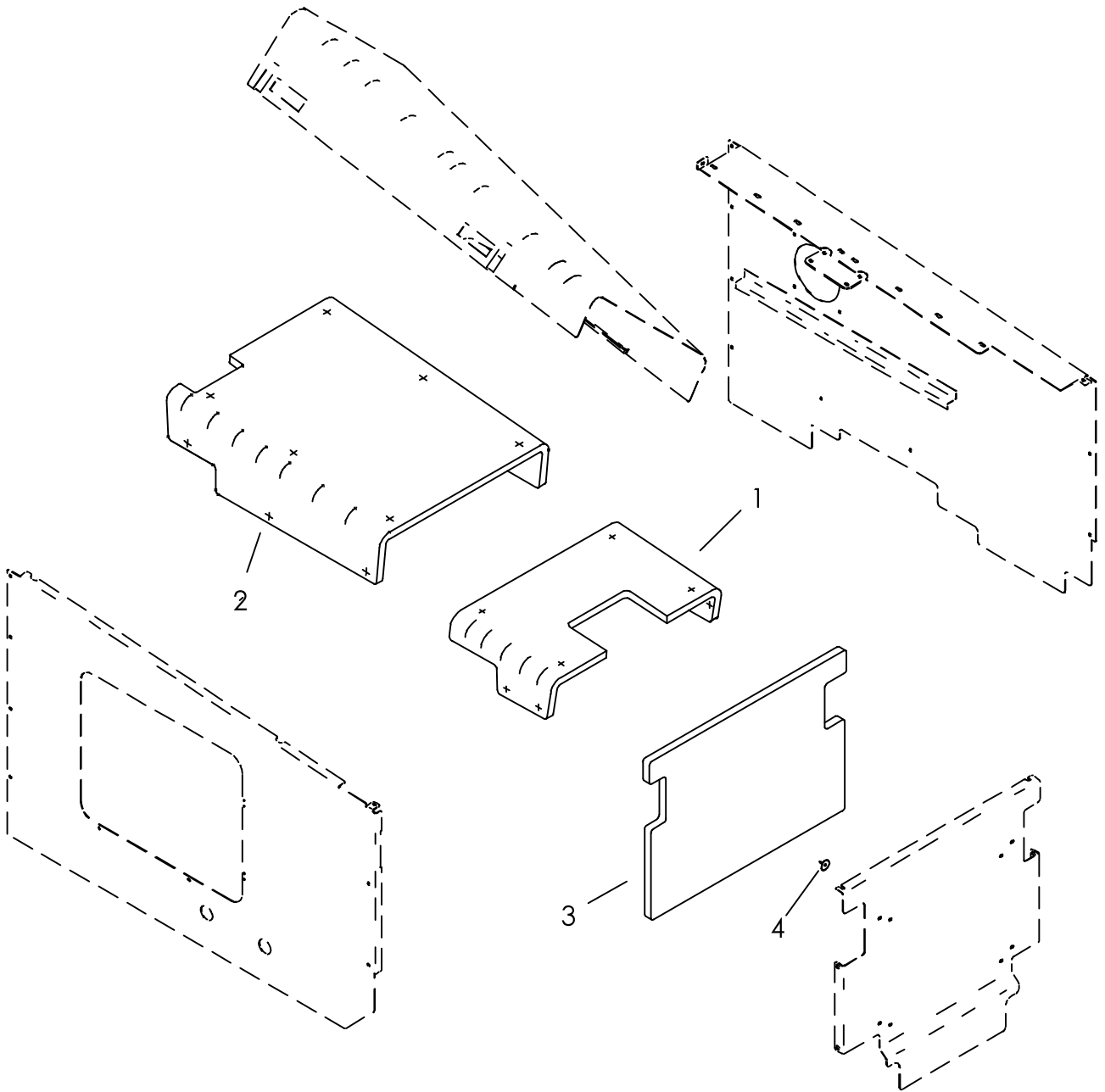

SOUND INSULATION ENGINE COVERS

REF NO.	PART NUMBER	QTY	DESCRIPTION	REMARKS
1.	354-937	1	SOUND INSULATION (HOOD-FRONT)	SEE FOOTNOTE 1, 2
2.	354-938	1	SOUND INSULATION (HOOD-REAR)	SEE FOOTNOTE 1, 2
3.	354-939	1	SOUND INSULATION (BATTERY PANEL)	
4.	107-950	20	INSULATION STUD	SEE FOOTNOTE 2

NOT SHOWN:

FOOTNOTES:

1. FIBERGLASS MUST BE SCORED ALONG BEND LINE TO ACHIEVE ACCEPTABLE BEND RESULTS
2. "X" MARKS ON INSULATION INDICATE APPROX LOCATION OF INSULATION STUDS

NOTE:

BATTERY COVERS

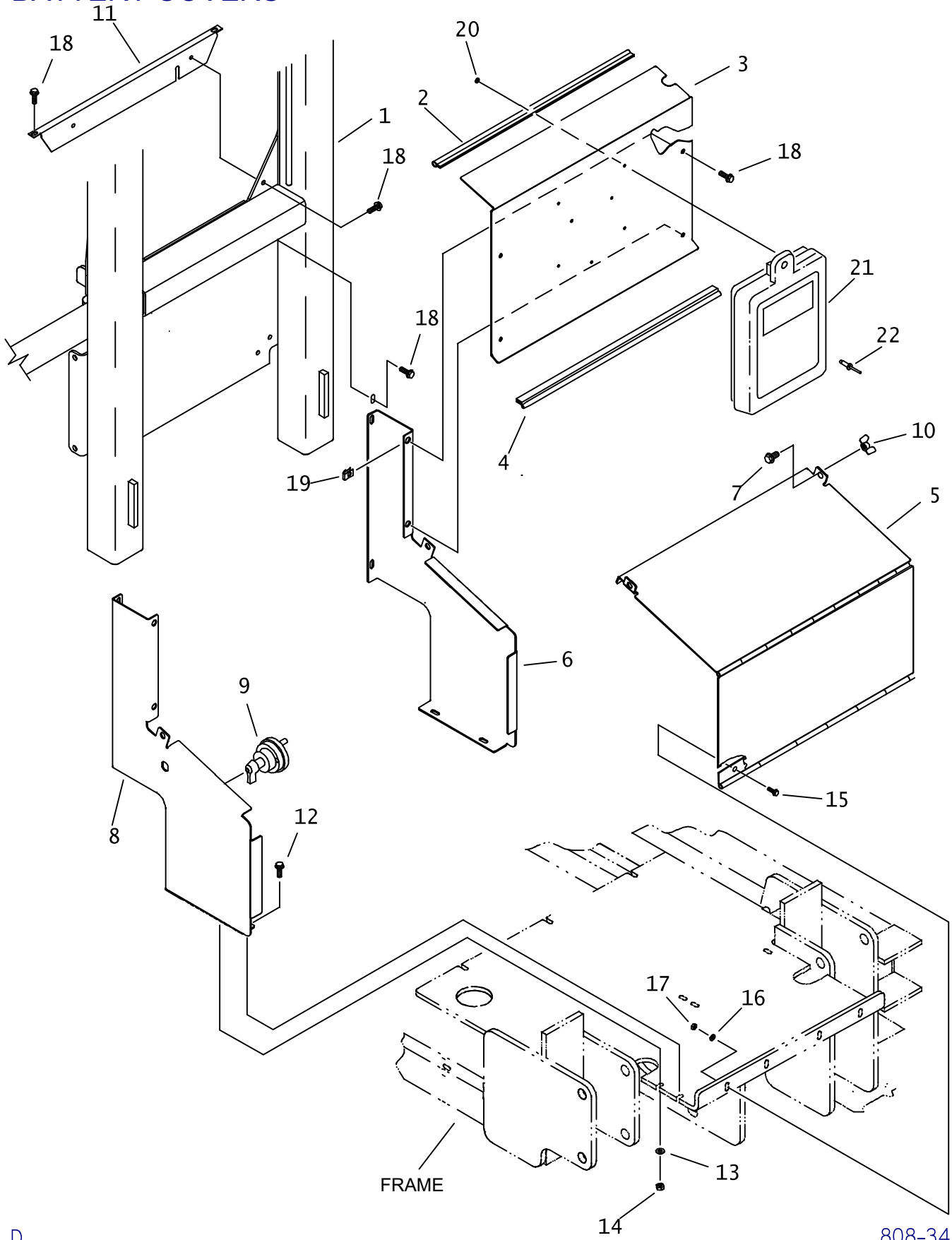

D

808-341

BATTERY COVERS

REF NO.	PART NUMBER	QTY	DESCRIPTION	REMARKS
1.	309-190	-	2-POST ROPS	
2.	116-421	AR	BULK EDGE (1/8", SOLD PER 1')	USE 1 @ 21.5"
3.	354-467	1	RELAY BOARD COVER	BEFORE S/N
	320-998	-	RELAY COVER	
4.	116-489	AR	BULK EDGE (1/8", SOLD PER 1')	USE 1 @ 22"
5.	354-880	1	BATTERY COVER	BEFORE S/N
	320-999	-	BATTERY COVER	
6.	354-469	1	BATTERY SIDE PANEL (LEFT)	BEFORE S/N
	322-370	-	BATTERY SIDE PANEL (LEFT)	
7.	105-825	2	FLG LK BOLT (3/8-NC X 3/4")	
8.	354-468	1	BATTERY SIDE PANEL (RIGHT)	BEFORE S/N
	322-371	-	BATTERY SIDE PANEL (RIGHT)	
9.	217-819	-	BATTERY DISCONNECT SWITCH	
10.	105-180	2	WING NUT (3/8-NC)	
11.	309-189	1	COVER PLATE	
12.	106-381	4	FLG LK SCREW (M8-1.25 X 25MM)	
13.	105-117	4	WASHER (5/16")	
14.	106-561	4	LOCKNUT (M8-1.25, PRV TRQ, 10.9)	
15.	106-988	4	FLG LK SCREW (M6-1.00 X 20MM)	
16.	105-117	4	WASHER (5/16")	
17.	106-538	4	LOCKNUT (M6-1.00, PRV TRQ, 10.9)	
18.	106-991	12	FLG LK SCREW (M8-1.25 X 20mm)	
19.	106-551	4	CLIP NUT (M8-1.25)	
20.	106-205	3	WASHER (.191")	
21.	318-588	1	MANUAL COMPARTMENT	
22.	110-560	4	POP RIVET (3/16" X 1/2", ALUM)	

FOOTNOTES

NOTE:

D

808-341

GAUGE PANEL

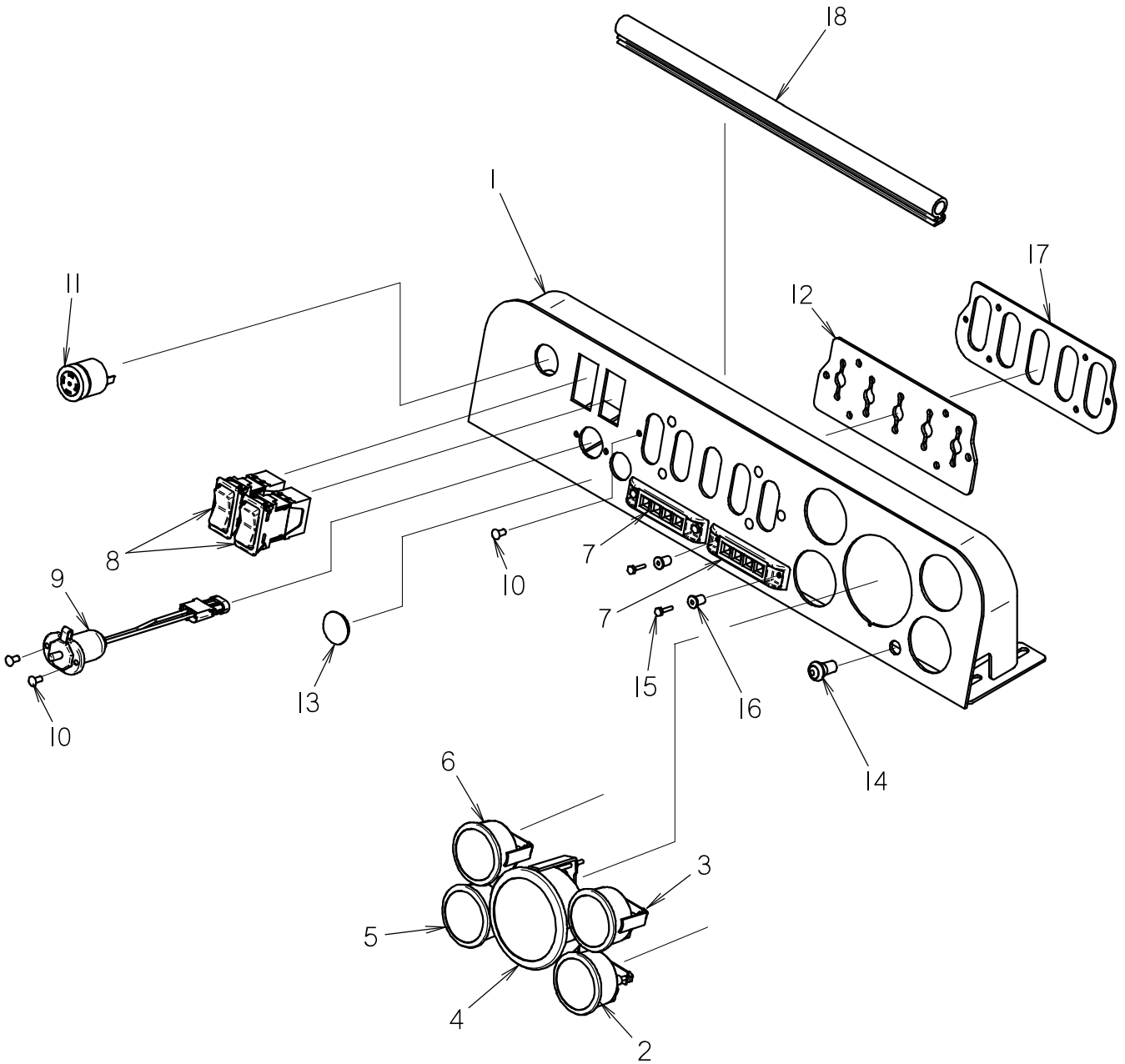

GAUGE PANEL

REF NO.	PART NUMBER	QTY	DESCRIPTION	REMARKS
I	300-1342	I	INSTRUMENT PANEL ASSEMBLY	
2	215-1268	I	2.06" CAN ENG OIL PRESS GAUGE	
3	215-1267	I	2.06" CAN COOLANT TEMP GAUGE	
4	211-325	I	3.5" CAN TACHOMETER W/ DISPLAY	
5	211-328	I	2.06" VOLTMETER GAUGE	
6	211-329	I	2.06" FUEL GAUGE	
7	220-664	2	INDICATOR ASSEMBLY	
8	217-907	2	ROCKER SWITCH (DPDT) ON-ON	
9	214-301	I	ACCESSORY SOCKET	
10	110-560	8	POP RIVET (3/16" X 1/2", ALUM)	
11	306-603	I	AUDIO ALARM	
12	117-383	I	CONTROL HANDLE SEAL	
13	111-112	I	PLUG (1.00)	
14	215-1015	I	MOMENTARY PUSH BUTTON SWITCH	SEE FOOTNOTE I
15	107-393	4	SCREW (M4-0.70 X 16MM, BX)	
16	107-358	4	WELLNUT (M4-0.7 X 12.67MM LG)	
17	310-126	I	SEAL BACK-UP PANEL	
18	116-489	AR	BULK EDGE (1/8",SOLD PER FT)	USE I @ 32.5"

NOT SHOWN:

FOOTNOTES:

I	217-291	2	TERMINAL SOCKET
	217-290	I	CONNECTOR
	217-289	I	SECONDARY LOCK

NOTE:

NOTES:

OPERATOR'S STATION

OPERATOR STATION

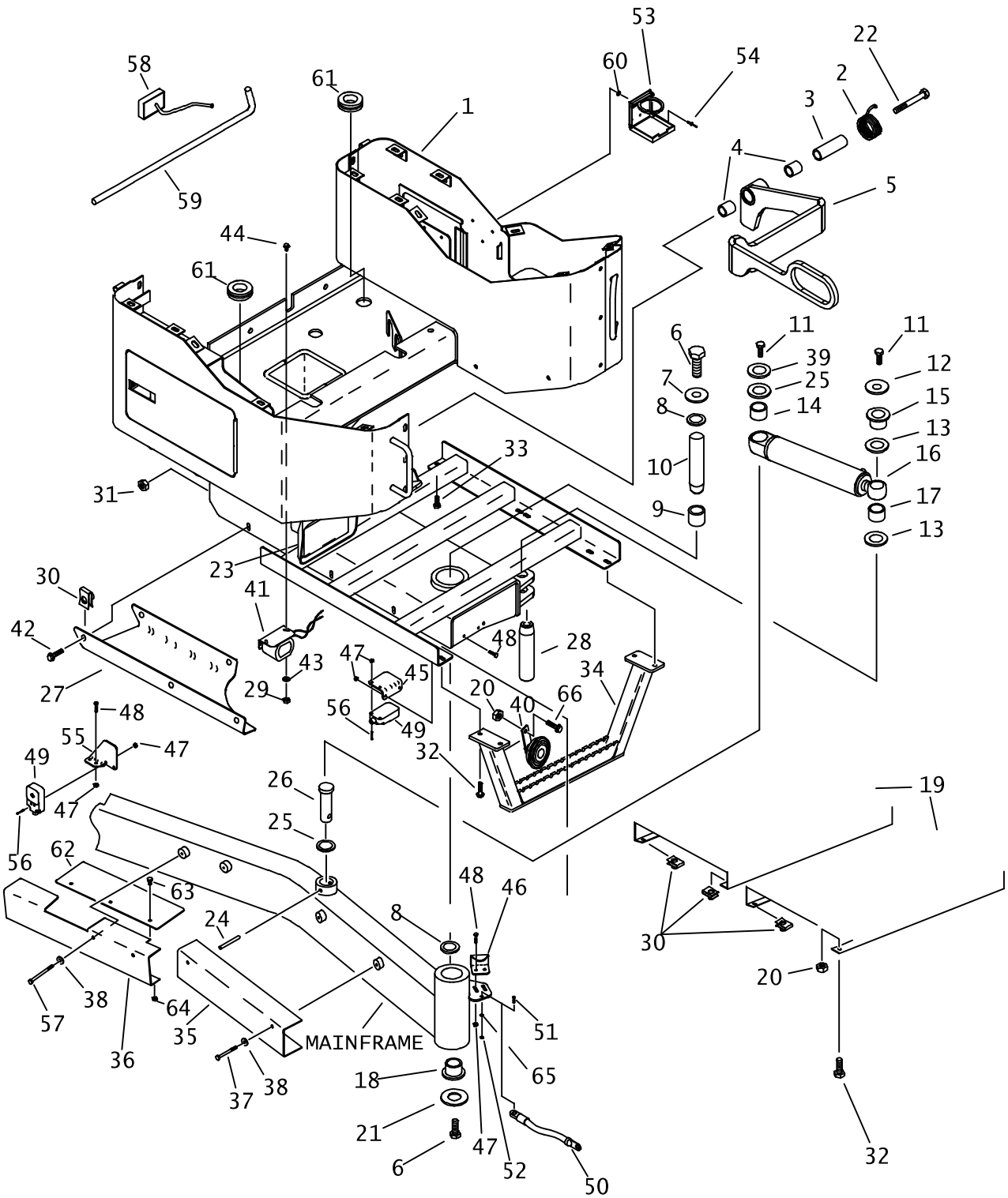

OPERATOR STATION

REF NO.	PART NUMBER	QTY	DESCRIPTION	REMARKS
1.	313-733	1	OPERATOR FRAME	
2.	117-156	1	TORSION SPRING	
3.	354-454	1	HANDLE SPACER	
4.	125-813	2	COMPOSITION BUSHING (1")	
5.	319-499	1	HANDLE	
6.	106-345	2	SCREW (M20-2.50 X 50mm)	
7.	105-423	1	WASHER (3/4")	
8.	111-001	2	WASHER (M51.2)	
9.	125-754	1	COMPOSITION BUSHING (2")	
10.	179-226	1	TAPERED PIN (50.8mm X 272mm)	
11.	105-245	2	SCREW (M10-1.50 X 25mm)	
12.	106-396	1	WASHER (M10, HARDENED)	
13.	110-084	2	BRASS BUSHING (1-5/32")	
14.	125-771	1	COMPOSITION BUSHING (1.25")	
15.	181-981	1	TAPERED INSERT (1")	
16.	151-031	1	CYL (2" X 1" X 8")	
17.	125-770	1	COMPOSITION BUSHING (1")	
18.	184-064	1	TAPERED INSERT (2")	
19.	350-989	2	FLOOR TREADS	
20.	106-561	5	LOCKNUT (M8-1.25, PRV TRQ, 10.9)	
21.	106-399	1	WASHER (M20, HARDENED)	
22.	106-336	1	SCREW (M12-1.75 X 90mm)	
23.	217-007	1	WORKING LIGHT (CLEAR, RECT)	
24.	105-503	1	ROLL PIN (1/4" X 2")	
25.	110-093	2	MACHINERY BUSHING (1-1/4", 18GA)	
26.	179-225	1	PIN (31.75mm X 60mm)	
27.	350-988	1	CHANNEL COVER	
28.	183-767	1	TAPERED PIN (25.4mm X 60mm)	
29.	106-538	2	LOCKNUT (M6-1.00, PRV TRQ, 10.9)	
30.	106-551	11	CLIP NUT (M8-1.25)	
31.	106-685	1	LOCKNUT (M12-1.75, PRV TRQ, 10.9)	
32.	106-381	5	FLG LK SCREW (M8-1.25 X 25MM)	
33.	106-992	6	FLG LK SCREW (M8-1.25 X 25MM)	
34.	354-488	1	STEP	
35.	354-500	1	WIRE COVER	
36.	314-723	1	COVER	
37.	106-595	2	SCREW (M6-1.00 X 60mm)	
38.	106-388	4	WASHER (M6)	
39.	105-223	1	WASHER (3/8")	
40.	192-006	1	HIGH FREQUENCY HORN	
	192-005	1	HORN BRACKET	
	306-609	1	HIGH FREQUENCY HORN-----	OBSOLETE
41.	214-416	1	HORN (ELECTRIC)	
42.	106-991	5	FLG LK SCREW (M8-1.25 X 20MM)	

NOT SHOWN:

FOOTNOTES:

NOTE:

OPERATOR STATION

REF NO.	PART NUMBER	QTY	DESCRIPTION	REMARKS
43.	106-389	2	WASHER (M8)	
44.	106-161	2	FLG SCREW (M6-1.00 X 20MM)	
45.	307-773	1	BRACKET, SWITCH	
46.	307-771	1	TARGET PLATE	
47.	106-850	10	LOCKNUT (M5-.80)	
48.	107-430	6	SCREW (M5 X 14MM)	
49.	215-1175	2	PROXIMITY SWITCH	
50.	214-088	1	CABLE ASS'Y (6GA X 200 MM)	
51.	106-217	1	BOLT (1/4-NC X 1", SIL BRZ)	
52.	106-455	1	LOCKNUT (1/4-NC, SIL BRZ)	
53.	354-905	1	CUP HOLDER	
54.	110-560	3	POP RIVET (3/16" X 1/2", ALUM)	
55.	307-772	1	BRACKET, SWITCH	
56.	106-427	4	SCREW (M5-0.80 X 22MM, SOC)	
57.	106-945	2	SCREW (M6-1.00 X 100MM)	
58.	211-042	1	CURRENT TRANSFORMER	
59.	215-799	1	VOLTAGE STAKE	
60.	106-205	3	WASHER (.191")	
61.	115-355	2	GROMMET (1-3/8)	
62.	315-649	1	PLATE	
63.	106-234	3	SCREW (M6-1.00 X 12MM)	
64.	106-106	3	NUT (M6-1.00)	
65.	106-221	1	INT STAR WASHER (1/4", SIL BRZ)	
66.	106-162	1	FLG SCREW (M8-1.25 X 20MM)	

NOT SHOWN:

107-269	4	SCREW (#4-40 X 3/4", PAN)
106-277	4	NUT (#4-40, BRASS)
117-283	1	ABRASION SLEEVE (4.000" X 20")

FOOTNOTES:

NOTE:

SEAT-BELT-COVER

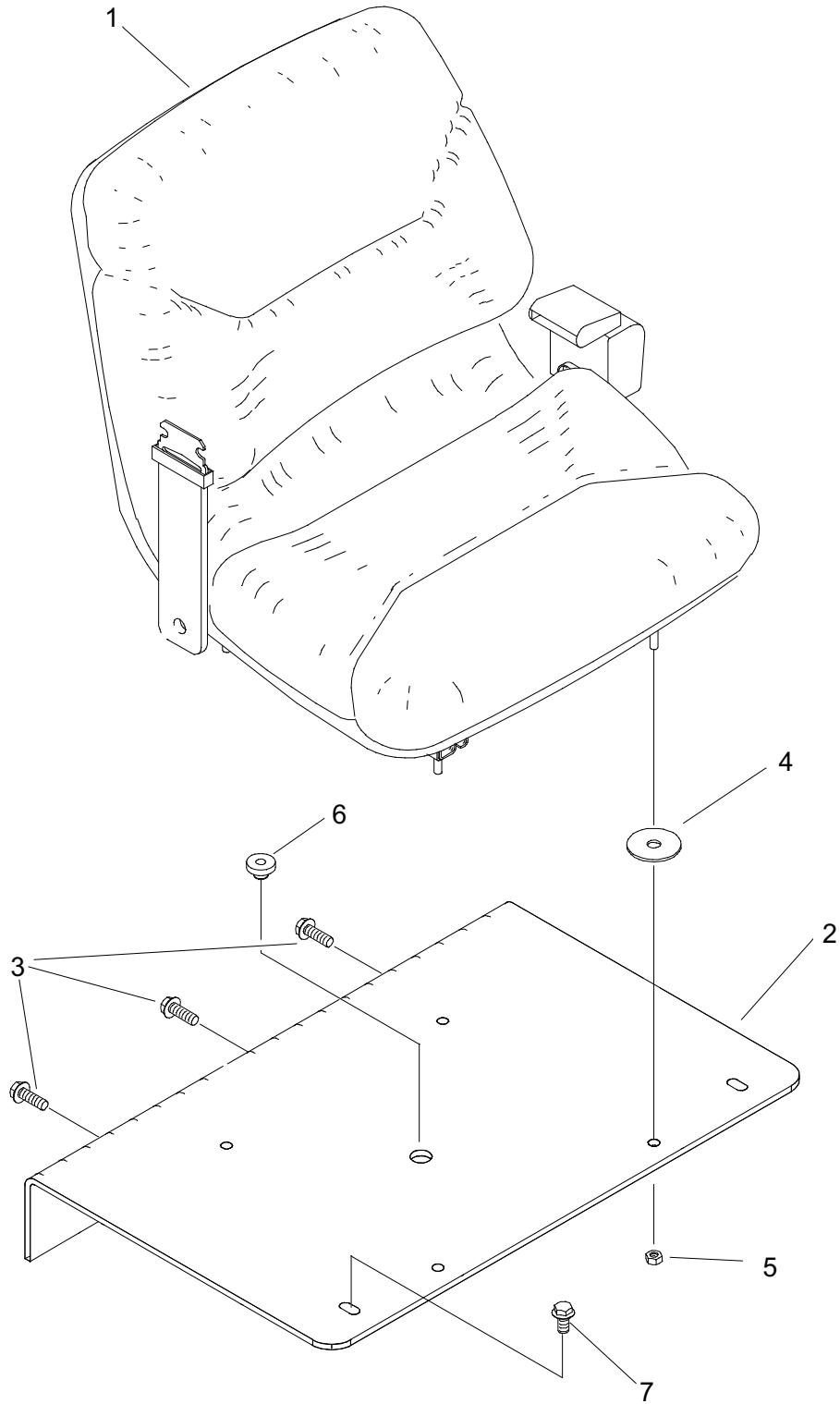

SEAT-BELT-COVER

REF NO.	PART NUMBER	QTY	DESCRIPTION	REMARKS
1.	117-1000	1	SEAT ASS'Y W/ SEAT BELT	INCL SWITCH
	214-964	-	SEAT SWITCH W/ BOOT	
	214-965	-	SEAT SWITCH HARNESS	
2.	308-787	1	SEAT BASE	
3.	107-001	3	FLG LK SCREW (M10-1.50 X 25mm)	
4.	105-267	4	CUP WASHER (5/16")	
5.	106-561	4	LOCKNUT (M8-1.25,PRV TRQ,10.9)	
6.	116-203	1	GROMMET (9/16")	
7.	106-999	2	FLG LK SCREW (M10-1.50 X 20mm)	

NOT SHOWN:

FOOTNOTES:

NOTE:

CONSOLE

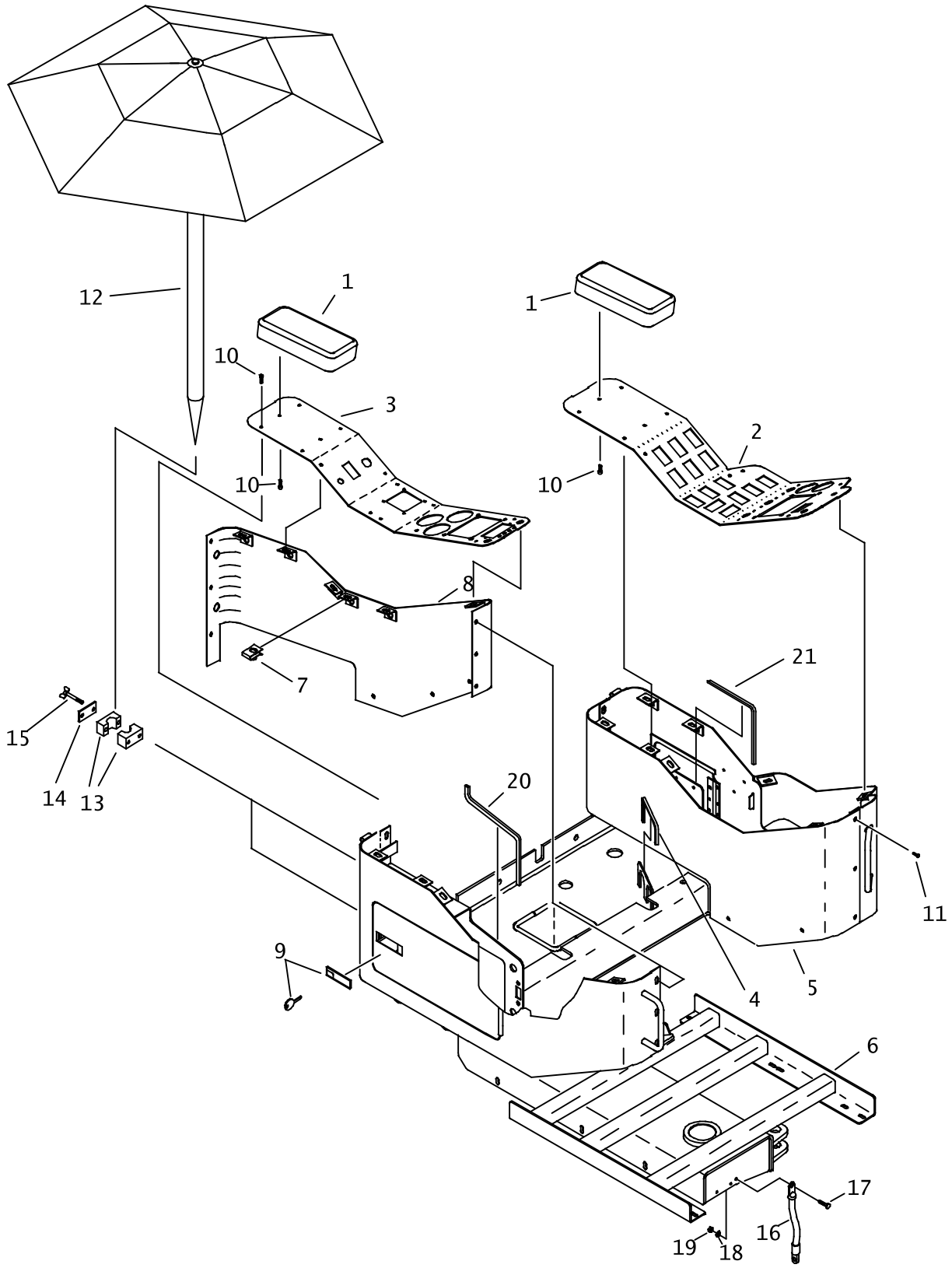

CONSOLE

REF NO.	PART NUMBER	QTY	DESCRIPTION	REMARKS
1.	350-389	2	ARM REST PAD	
2.	313-729	1	LEFT CONSOLE COVER	
3.	211-011	1	RIGHT CONSOLE	
4.	116-789	AR	RUBBER EDGE TRIM 1/8" (12 GA)	USE 2 @ 10"
5.	350-749	1	LEFT CONSOLE	
6.	313-733	-	OPERATOR FRAME	
7.	106-574	37	CLIP NUT (M6-1.00)	
8.	308-790	1	RIGHT CONSOLE	
9.	117-558	2	ADJUST LEVER LATCH (LOCKING)	
	214-961		KEY, PAIR (BASE CODE)	
	217-309		LOCK PLUG 4/LATCH (BASE CODE)	
	<u>110-757</u>	2	LEVER LATCH (ADJUST LOCKING)	INCLUDES KEYS
	110-596	-	KEY (PAIR)	
10.	106-640	24	SCREW (M6-1.00 X 20mm, BUT SOC)	
11.	106-988	17	FLG LK SCREW (M6-1.00 X 20mm)	
12.	344-700	1	UMBRELLA (6.5')	
13.	111-026	2	BOLT-ON CLAMP (1-1/4", PAIR)	
14.	322-362	2	BACKUP SPACER	
15.	105-621	4	WING BOLT (1/4-NC X 3")	
16.	214-088	-	CABLE ASS'Y (6GA X 200 MM)	
17.	106-217	1	BOLT (1/4-NC X 1", SIL BRZ)	
18.	106-221	1	INT STAR WASHER (1/4", SIL BRZ)	
19.	106-455	1	LOCKNUT (1/4-NC, SIL BRZ)	
20.	116-789	AR	RUBBER EDGE TRIM 1/8" (12 GA)	USE 1 @ 19"
21.	116-789	AR	RUBBER EDGE TRIM 1/8" (12 GA)	USE 1 @ 22"

FOOTNOTES

NOTE:

LEFT CONSOLE RELAY PANEL

JT 4020 T3

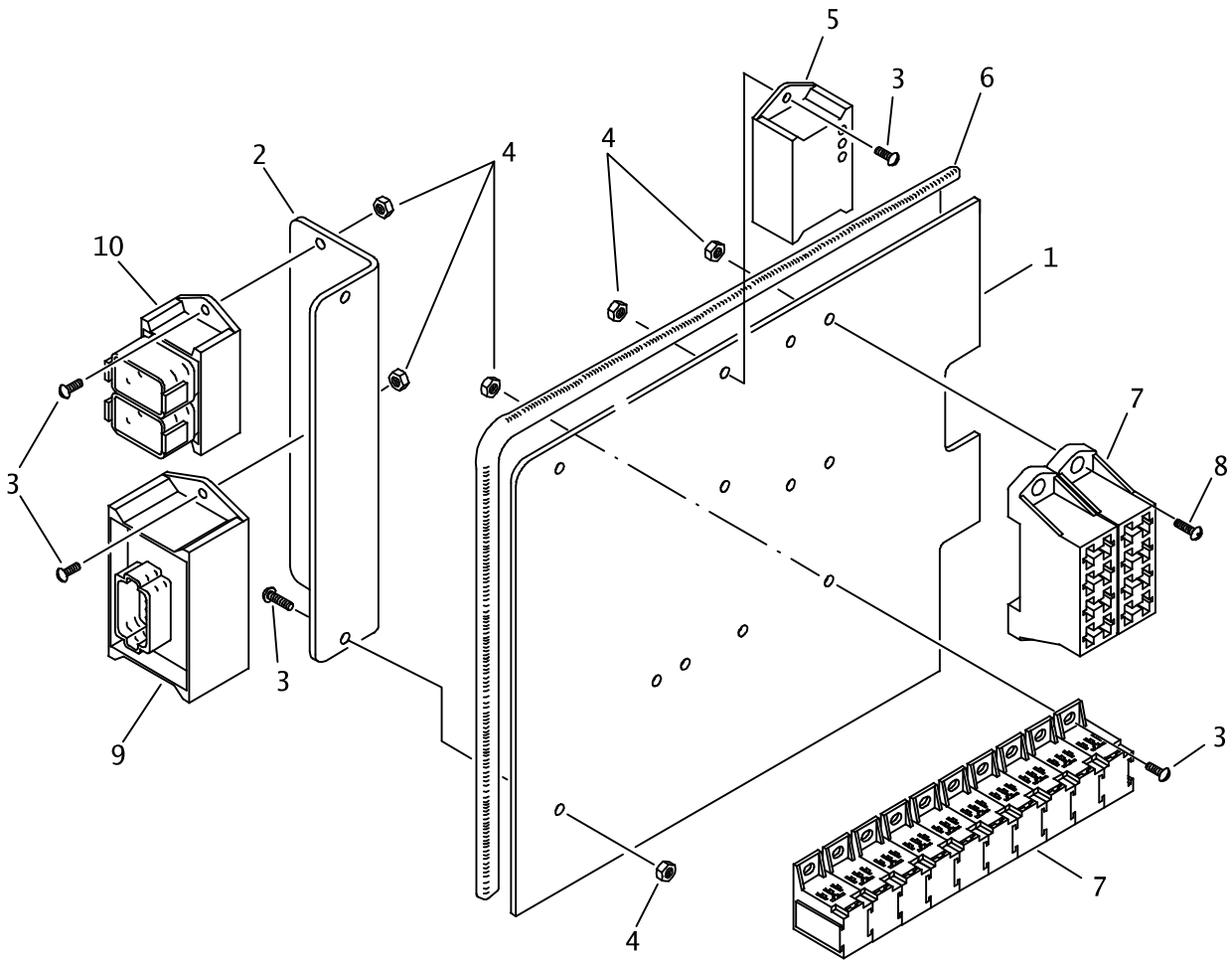

LEFT CONSOLE RELAY PANEL

JT 4020 T3

REF NO.	PART NUMBER	QTY	DESCRIPTION	REMARKS
1.	308-794	-	OPERATOR FRAME	
2.	310-982	1	BRACKET	
3.	105-185	14	BOLT (#10-24 X ", RD SLT)	
4.	106-048	18	LOCKNUT (#10-24)	
5.	217-184	-	DELAY TIMER (2-SECOND)	
6.	116-789	AR	RUBBER EDGE TRIM ", (FT)	USE 1 @ 22.0"
7.	215-1022	-	OPERATOR STATION HARNESS	
8.	106-049	4	BOLT (#10-24 Xf", PLPS)	
9.	211-031	-	BORE/MOBILE RESISTOR PACK	
10	211-026	-	DIODE PACK (DEUTSCH)	

NOT SHOWN:

FOOTNOTES:

NOTE:

CONSOLE GAUGES

JT4020 T3

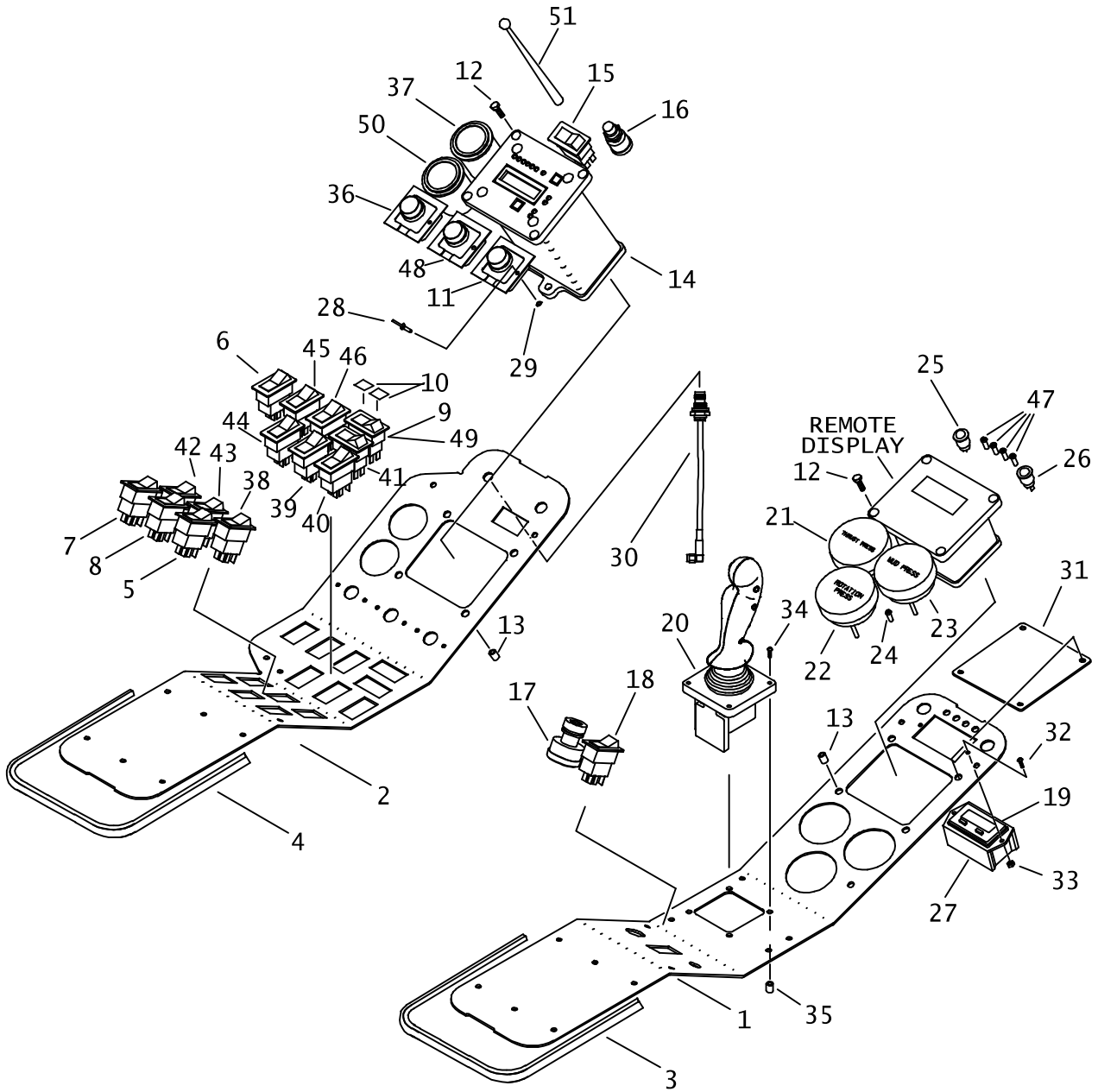

CONSOLE GAUGES

JT4020 T3

REF NO.	PART NUMBER	QTY	DESCRIPTION	REMARKS
1.	211-011	-	RIGHT CONSOLE COVER	
2.	313-729	-	LEFT CONSOLE COVER	
3.	116-789	AR	RUBBER EDGE TRIM 1/8 " (12 GA)	USE 1 @ 86"
4.	116-789	AR	RUBBER EDGE TRIM 1/8 " (12 GA)	USE 1 @ 83"
5.	217-911	-	ROCKER SW (SPDT) ON-OFF-ON	THROTTLE
6.	217-908	1	ROCKER SWITCH (DPDT) ON-ON-ON	INNER SPINDLE ON-OFF-(MAN), AT ONLY
	110-962	-	FILLER PLUG	JT ONLY
7.	217-912	-	ROCKER SWITCH (DPDT) ON-ON-ON	BORE/BACKREAM
8.	217-907	-	ROCKER SWITCH (DPDT) ON-ON	OUTER SPINDLE BRAKE
9.	217-923	-	ROCKER SW (DPDT) ON-OFF-ON	MOBILE/BORE
10.	217-156	2	DIFFUSION LENS (GREEN)	
11.	214-566	-	POTENTIOMETER	DRILL FLUID POT.
12.	106-640	8	SCREW (M6-1.00 X 20MM, BUT SOC)	
13.	105-630	8	NUTSERT(M6X1.0).70-4.20THK	
14.	220-1024	-	ESID MODULE	ELECTRICAL STRIKE SYSTEM
15.	217-911	-	ROCKER SWITCH (SPDT) ON-OFF-ON	SEAT ROTATE
16.	306-607	-	HORN BUTTON	HORN
	306-608	-	BUTTON COVER	
17.	214-852	1	IGNITION SWITCH	
	214-961	-	KEY, PAIR	
	214-962	-	SWITCH MOUNTING NUT	
18.	217-917	-	ROCKER SWTCH (DPDT) OFF-(ON)	ENGINE OVERRIDE
19.	319-412	1	FLOW METER WEATHER COVER	
20.	215-1224	-	DUAL AXIS HALL EFFECT JOYSTICK	JOYSTICK
21.	258-063	-	GAUGE (4000 PSI)	THRUST PRESSURE GAUGE
22.	258-061	-	HYD PRESSURE GAUGE (6000 PSI)	INNER/OUTER ROTATION PRESSURE GAUGE
23.	150-1964	-	PRESSURE GAUGE (2000PSI)	MUD PRESSURE GAUGE
24.	214-701	-	STATUS LIGHT	"MUD ON" LED
25.	214-563	-	RED LED 12V	DIAGNOSTIC LIGHT
26.	214-840	-	GREEN LED (12V DC)	CONTROL CYCLE LIGHT
27.	217-221	-	FLOW METER DISPLAY	MUD FLOW METER
28.	110-560	6	POP RIVET (3/16" X 1/2 ", ALUM)	
29.	106-205	6	WASHER (.191")	
30.	214-413	-	RIG RF CABLE 2130MM	
31.	348-896	1	COVER PLATE	COVER FOR HOLE WHEN REMOTE DISPLAY IS NOT INSTALLED.
32.	106-049	2	BOLT (#10-24 X 3/4 ", PLPS)	
33.	106-048	2	LOCKNUT (#10-24)	
34.	107-414	4	SCREW (M4-0.70 X 30MM, BUT SOC)	
35.	107-635	4	NUTSERT (M4 X 0.7)	
36.	211-089	-	4.5V-12.0V POTENTIOMETER	INNER SPINDLE POT., AT ONLY
37.	217-561	-	SPINDLE TACHOMETER (250 RPM)	OUTER SPINDLE TACH, AT ONLY
	111-067	-	EXPANSION PLUG (2.125")	JT ONLY
38.	214-489	-	ROCKER SW (DPDT) (ON)-OFF-(ON)	PIPE SHUTTLE
39.	217-907	-	ROCKER SWITCH (DPDT) ON-ON	REAR WRENCH

FOOTNOTES:

NOTE:

CONSOLE GAUGES

JT4020 T3

REF NO.	PART NUMBER	QTY	DESCRIPTION	REMARKS
40.	217-907	-	ROCKER SWITCH (DPDT) ON-ON	FRONT WRENCH
41.	214-489	-	ROCKER SW (DPDT) (ON)-OFF-(ON)	LUBER
42.	214-489	-	ROCKER SW (DPDT) (ON)-OFF-(ON)	PIPE LIFT
43.	214-489	-	ROCKER SW (DPDT) (ON)-OFF-(ON)	PIPE GRIP
44.	214-489	-	ROCKER SW (DPDT) (ON)-OFF-(ON)	WRENCH ROTATE
45.	214-489	-	ROCKER SW (DPDT) (ON)-OFF-(ON)	INNER SPINDLE MANUAL CW/CCW, AT ONLY
	110-962	-	FILLER PLUG	JT ONLY
46.	214-489	-	ROCKER SW (DPDT) (ON)-OFF-(ON)	CRUISE CONTROL
47.	214-701	-	STATUS LIGHT	
48.	214-566	-	POTENTIOMETER	OUTER SPINDLE POT.
49.	217-925	-	ROCKER SWITCH (ACTUATOR)	
50.	215-1561	-	SPINDLE TACHOMETER (300 RPM)	INNER SPINDLE TACH, AT ONLY
	111-067	-	EXPANSION PLUG (2.125")	JT ONLY
51.	221-177	-	ANTENNA UHF US-UK EXR450TN CEN	USA
	219-948	-	ANTENNA 420-450MHZ RT ANG TNC	INTERNATIONAL

FOOTNOTES:

NOTE:

DUAL AXIS JOYSTICK

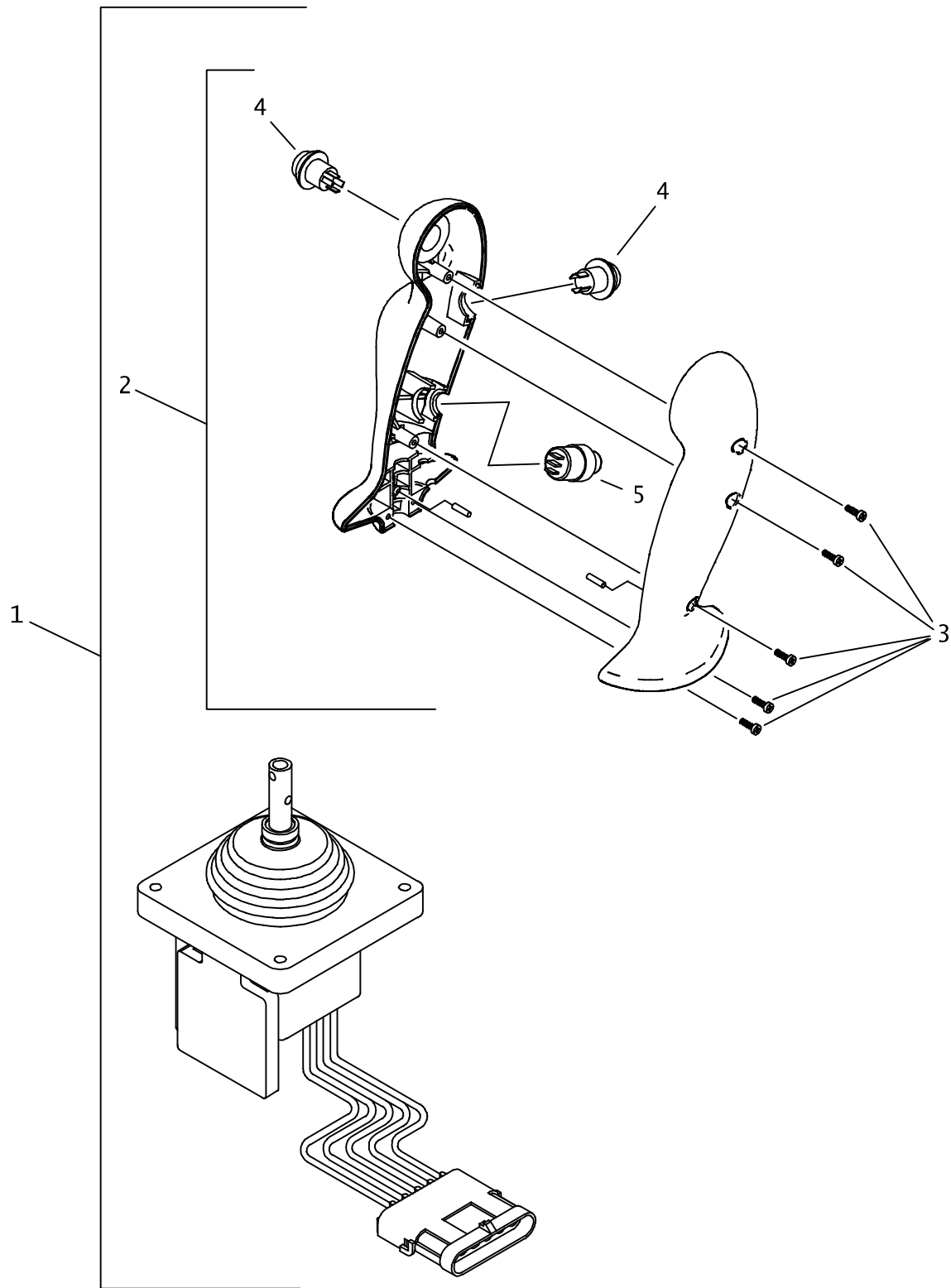

DUAL AXIS JOYSTICK

REF NO.	PART NUMBER	QTY	DESCRIPTION	REMARKS
1.	215-1224	-	DUAL AXIS JOYSTICK	
2.	500-1433	-	JOYSTICK HANDLE ASSEMBLY	INCLUDES REF No's 3,4,& 5
3.	107-410	-	SCREW (#2.5 X 8", PAN, PLASTIC)	
4.	214-614	-	PUSHBUTTON SW (SPST) OFF-(ON)	
5.	214-616	-	PUSHBUTTON SW (SPDT) ON-ON	

NOT SHOWN:

FOOTNOTES:

NOTE:

NOTES:

TRACK FRAME & MAIN FRAME

TRACK GROUP

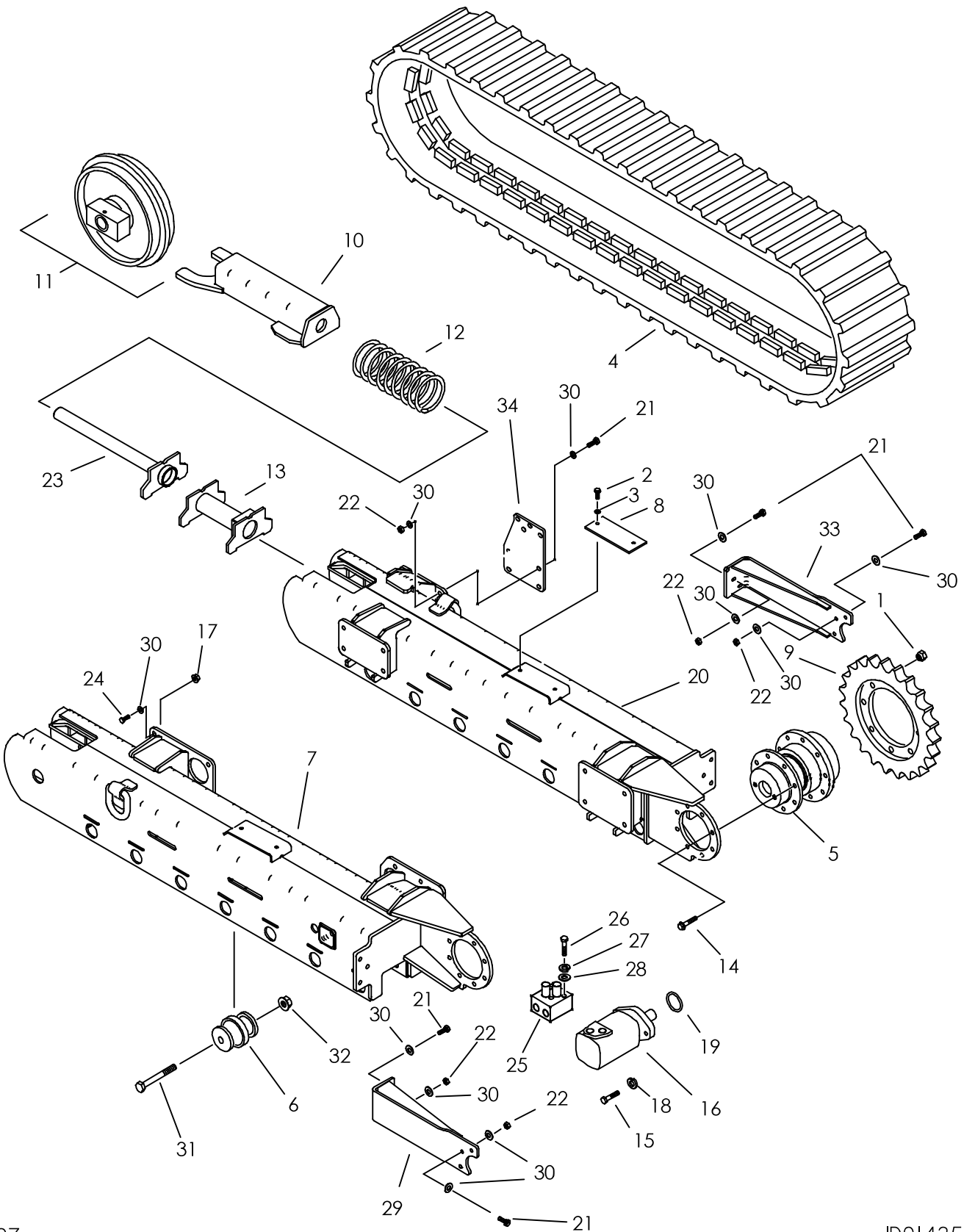

TRACK GROUP

REF NO.	PART NUMBER	QTY	DESCRIPTION	REMARKS
1.	106-066	16	LUG NUT (5/8-NF)	
2.	107-010	4	FLG LOCK SCREW (M12-1.75 X 30mm)	
3.	106-397	4	WASHER (M12, HARDENED)	
4.	354-480	2	RUBBER TRACK (400MM,82P,72MM)	
5.	166-417	2	PLANETARY GEARBOX	TRACK PLANETARY, USE 500-2009 O-RING/GASKET KIT
	500-1755	-	INPUT SHAFT	
6.	354-861	14	ROLLER	
7.	350-757	1	LEFT ROLLER FRAME	
8.	349-314	2	SLIDE PAD	
9.	141-578	2	SPROCKET (20T)	
10.	354-517	2	YOKE	
11.	354-860	2	IDLER PARTS ASS'Y	
12.	117-164	2	COMPRESSION SPRING	COMPRESSED LENGTH 18" +0 -1/4" TO KEEP TRACKS TIGHT
13.	354-531	1	RIGHT GREASE CYLINDER	
	354-530	1	LEFT GREASE CYLINDER	
14.	105-970	16	FLG BOLT (5/8-NC X 2-1/2")	USE 242 LOCTITE
15.	107-773	4	SCREW (1/2-NC X 4.25", GD8)	USE 242 LOCTITE; TORQUE TO 130 FT LB
16.	153-592	1	HYDRAULIC MOTOR	RIGHT SIDE, USE SEAL KIT 500-752
	153-593	1	HYDRAULIC MOTOR	LEFT SIDE
17.	106-442	16	FLG LKNUT (M16-2.00, PRV TRQ, 10.9)	TORQUE SPECS.: SEE FOOTNOTE 1
18.	105-070	4	LOCK WASHER (.500")	
19.	155-768	2	O-RING (155 D70)	
20.	350-758	1	RIGHT ROLLER FRAME	
21.	106-616	20	SCREW (M16-2.00 X 55mm, 10.9)	
22.	106-545	27	LOCKNUT (M16-2.00,PRV TRQ, 10.9)	
23.	354-529	2	SPRING GUIDE	
24.	107-598	16	SCREW (M16 X 60MM 10.9)	
25.	153-767	2	COUNTERBALANCE MANIFOLD	
	158-020	2	HYDRAULIC VALVE	
26.	107-739	8	SCREW (3/8-NF X 5.25", GD 5)	
27.	105-072	8	LOCK WASHER (3/8")	
28.	106-390	8	WASHER (M10)	
29.	354-569	1	LEFT TRACK GUARD	
30.	106-398	56	WASHER (M16, HARDENED)	
31.	105-597	14	BOLT (1-NC X 7.50", GD8)	USE 242 LOCTITE
32.	105-919	14	FLG NUT (1-NC)	
33.	354-570	1	RIGHT TRACK GUARD	
34.	350-831	1	ROPS SUPPORT PLATE	

NOT SHOWN:

FOOTNOTES:

1. APPLY LOCTITE 242;TIGHTEN ALL TRACK-MAIN FRAME JOINT FASTENERS TO 150 FT LB AND FINAL TORQUE OF 225 FT LB AT NUT; OR INITIAL TORQUE TO 125 FT LB AND FINAL TORQUE TO 185 FT LB AT BOLT HEAD. DO NOT DRAW MATING SURFACES TOGETHER WITH A SINGLE NUT-BOLT COMBINATION.

NOTE:

IDLER

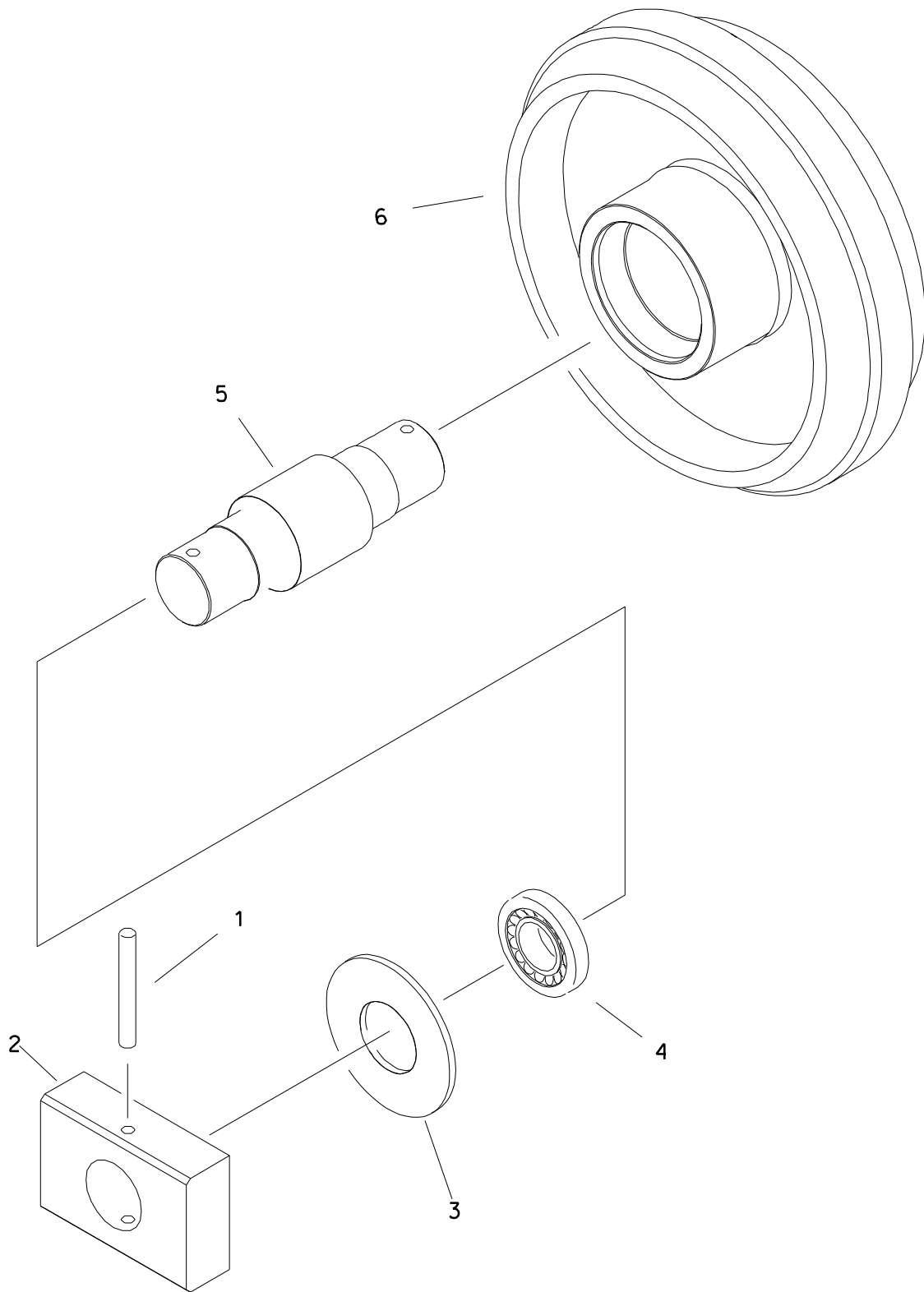

IDLER

REF NO.	PART NUMBER	QTY	DESCRIPTION	REMARKS
	354-860		IDLER	INCL REF NO'S 1 - 6
1.	107-295	2	ROLL PIN (.375" X 3.75")	
2.	354-833	2	OUTER BLOCK	
3.	125-482	2	WASHER (2.283")	
4.	125-134	2	BALL BEARING (2.362")	PACK WITH GREASE
5.	354-827	1	IDLER SHAFT	
6.	350-515	1	IDLER	PACK INSIDE WITH GREASE

FOOTNOTES

ROLLER

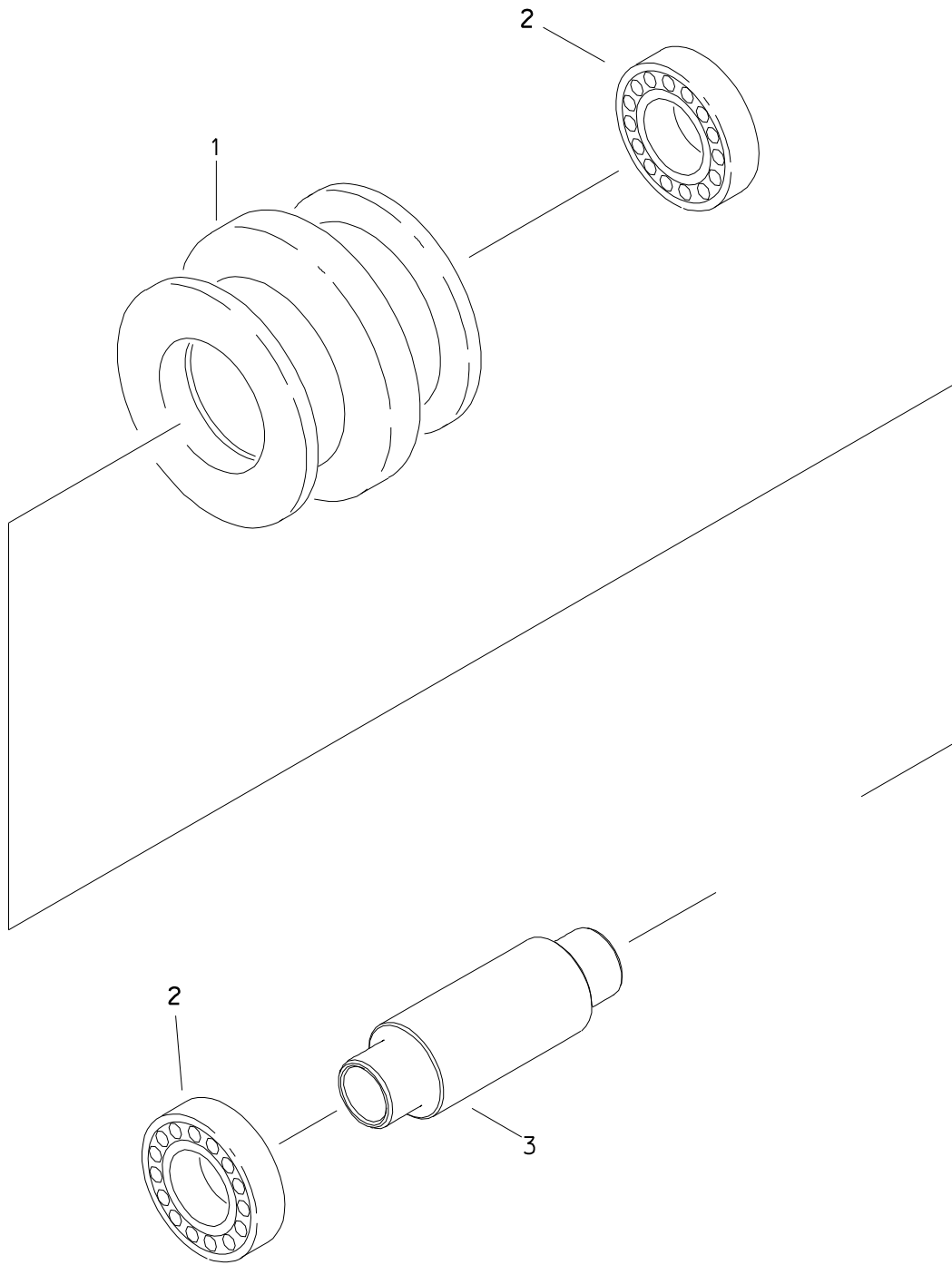

ROLLER

REF NO.	PART NUMBER	QTY	DESCRIPTION	REMARKS
	354-861		ROLLER	INCL REF NO'S 1-3
1.	170-341	1	ROLLER SHELL	
2.	125-138	2	BALL BEARING (1.250")	
3.	167-336	1	SHAFT	

FOOTNOTES

GREASE CYLINDER

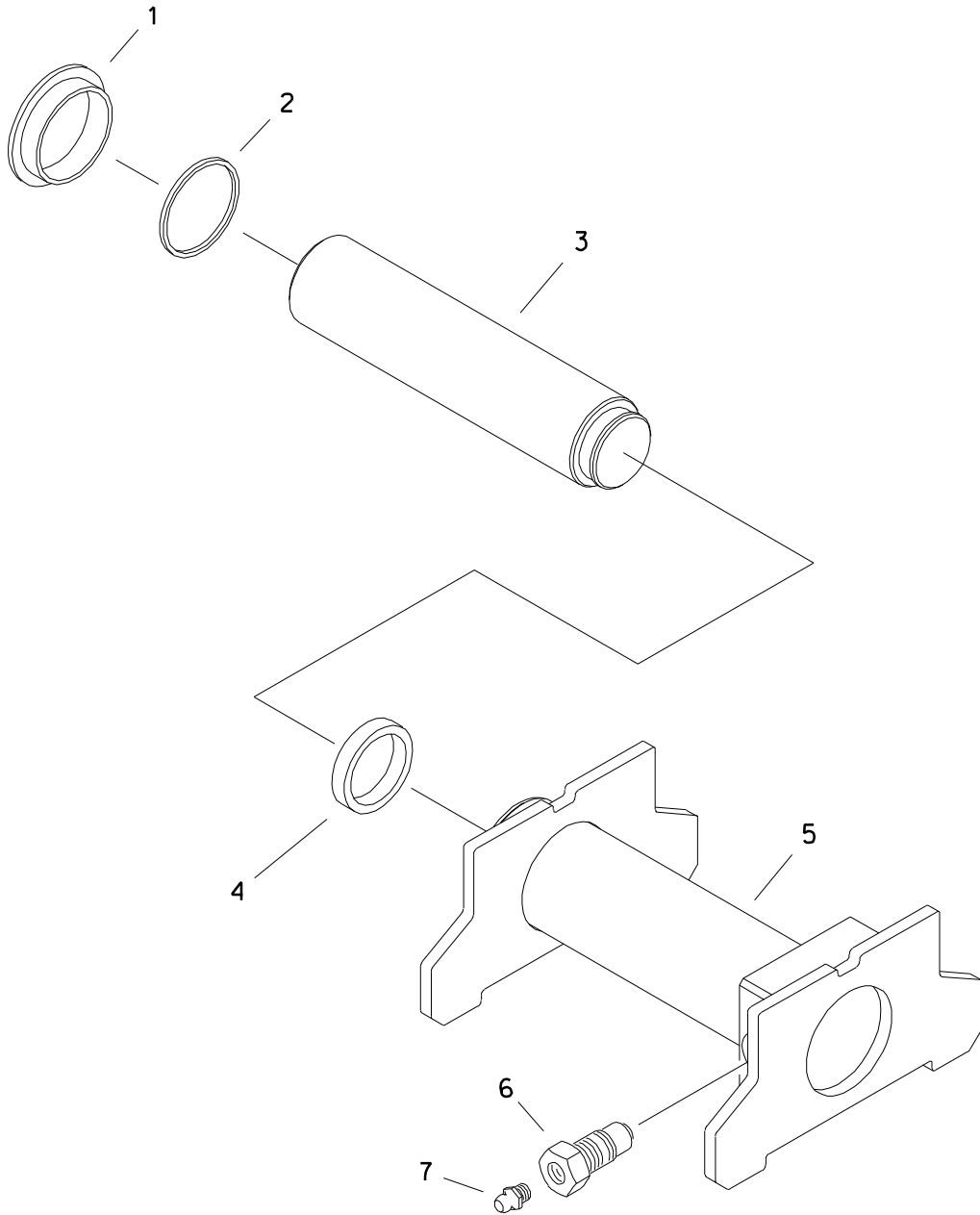

GREASE CYLINDER

REF NO.	PART NUMBER	QTY	DESCRIPTION	REMARKS
	354-530	1	LEFT GREASE CYLINDER	INCL REF NO'S 1 THRU 7
	354-531	1	RIGHT GREASE CYLINDER	INCL REF NO'S 1 THRU 7
1.	157-562	1	RETAINER RING (2.625")	
2.	157-561	1	ROD WIPER (2.492")	
3.	150-682	1	GREASE CYLINDER ROD	
4.	157-560	1	PISTON SEAL (1.975")	
5.	151-184	1	RIGHT BARREL	
	151-183	1	LEFT BARREL	
6.	159-093	1	RELIEF VALVE (5/8-NF, Q2N)	
7.	115-019	1	ZERK (Q2N)	

FOOTNOTES

REAR STABILIZER

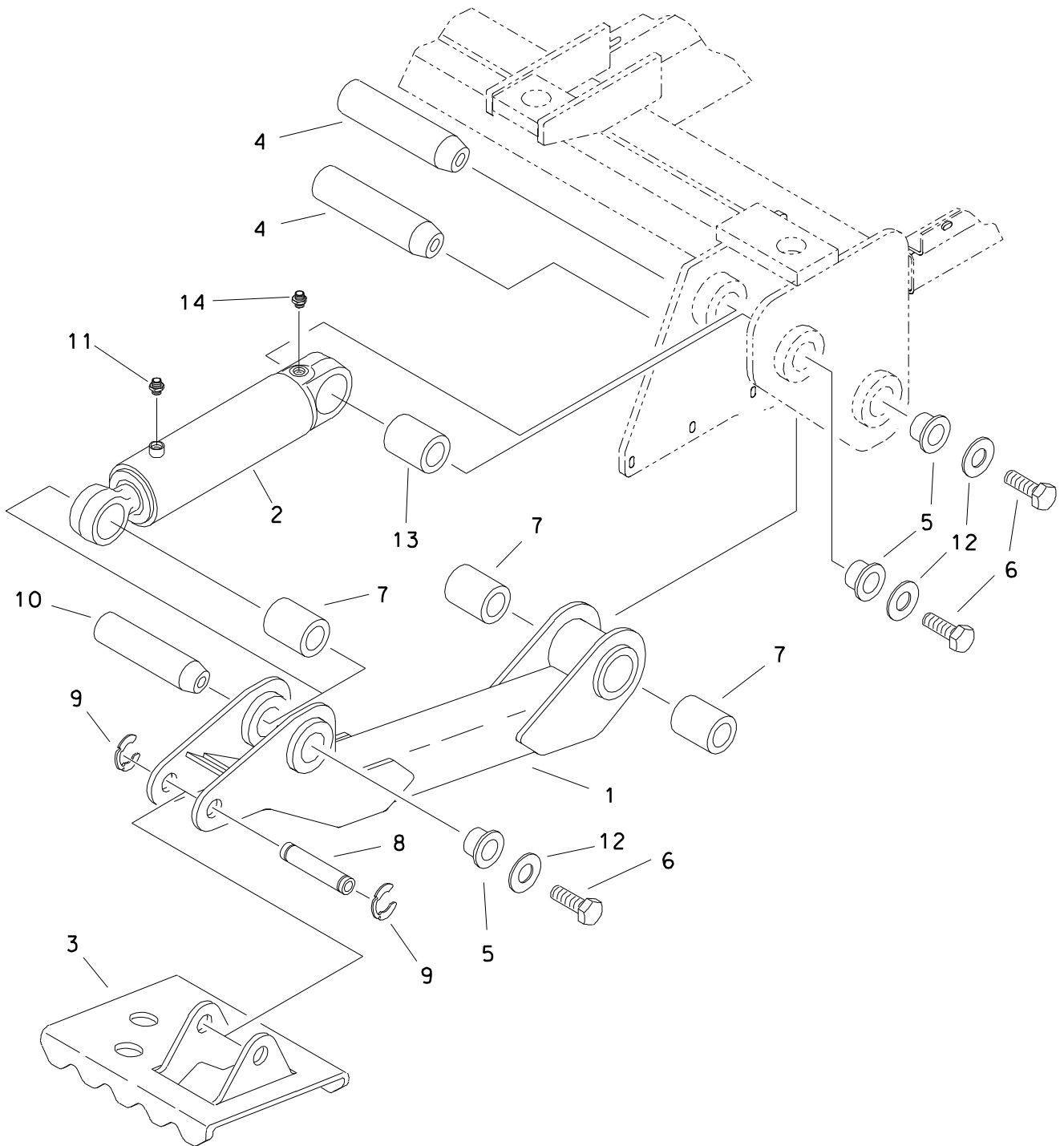

REAR STABILIZER

REF NO.	PART NUMBER	QTY	DESCRIPTION	REMARKS
1.	350-508	1	RIGHT STABILIZER	
	354-537	1	LEFT STABILIZER	
2.	151-187	2	CYLINDER ASSEMBLY	4" X 2" X 10"
3.	350-850	1	RIGHT STABILIZER PAD	
	354-536	1	LEFT STABILIZER PAD	
4.	179-223	4	TAPERED PIN (50.8mm X 208mm)	
5.	184-064	6	TAPERED INSERT (2")	
6.	106-798	6	SCREW (M20-2.50 X 55mm, 10.9)	
7.	125-754	6	COMPOSITION BUSHING (2")	
8.	179-224	2	PAD PIN	
9.	115-483	4	KLIP RING (1.25")	
10.	183-832	2	TAPERED PIN (50.8MM X 135MM)	
11.	154-261	2	CONNECTOR (040-08S)	
12.	106-399	6	WASHER (M20, HARDENED)	
13.	125-844	2	COMPOSITION BUSHING (2")	
14.	154-374	2	CONNECTOR (040-08S, DRF)	

FOOTNOTES

NOTES

REFER TO O-RING CHART (800-301) IN BACK OF BOOK FOR REPLACEMENT OF O-RINGS.

FUEL TANK

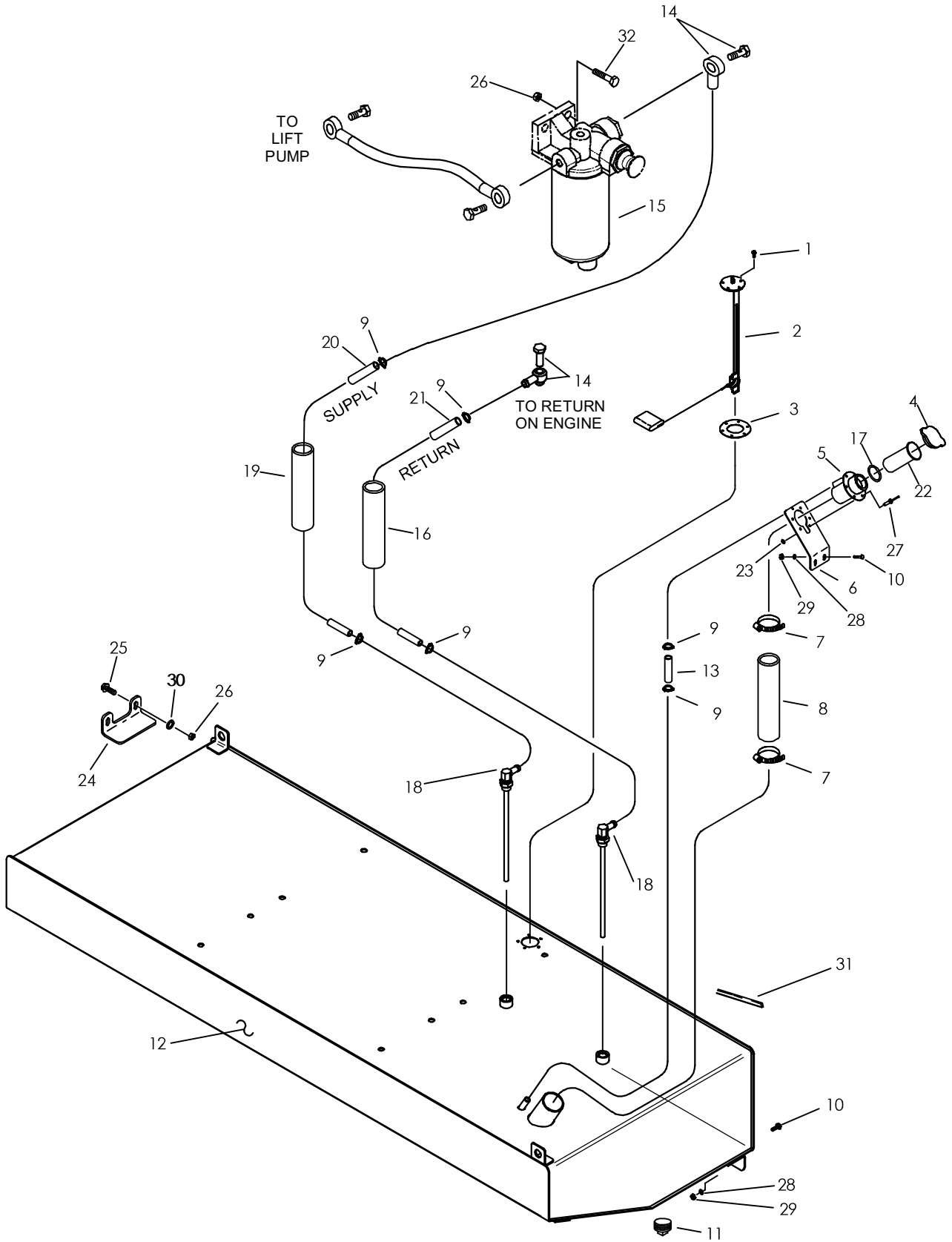

FUEL TANK

REF NO.	PART NUMBER	QTY	DESCRIPTION	REMARKS
1.	105-214	5	FLG SCREW (#10-24 X 1/2")	
2.	217-568	1	FUEL SENDER	
3.	165-704	1	GASKET	
4.	110-010	1	FUEL CAP (1-1/2")	
5.	364-645	1	FILLER NECK	
6.	364-487	1	FUEL FILL BRACKET	
7.	110-134	2	WORM CLAMP (2-1/16" TO 2-3/4")	
8.	105-1110	1	FUEL HOSE (12-1/2")	
9.	110-217	4	WORM CLAMP (7/16" TO 1")	
10.	106-162	6	FLG SCREW (M8-1.25 X 20mm)	
11.	115-152	1	PLUG (12N, SQ, FM)	
12.	300-1949	1	FUEL TANK	
13.	116-322	AR	BULK HOSE (1/2", SOLD PER 1")	USE I @ 16"
14.	150-1231	2	S/O COUPLER (M12-1.5-08H90)	
15.	195-1035		PRIMARY FUEL FILTER	
	195-1036		SECONDARY FUEL FILTER	
16.	118-062	1	ABRASION SLEEVE (1.00" X 62")	
17.	155-708	1	O-RING (218-D70)	
18.	150-1229	2	PICKUP TUBE (08H90)	
19.	117-412	1	ABRASION SLEEVE (1.00" X 34")	
20.	116-322	AR	BULK HOSE (1/2", SOLD PER 1")	USE I @ 36"
21.	116-322	AR	BULK HOSE (1/2", SOLD PER 1")	USE I @ 63"
22.	364-663	1	FILLER NECK SCREEN	
23.	106-205	4	WASHER (.191")	INSTALL ON POP RIVET 110-253
24.	354-973	2	TANK CLAMP	
25.	106-632	4	FLG LK SCREW (M12-1.75 X 35mm, SER)	
26.	106-685	6	LOCKNUT (M12-1.75, PRV TRQ, 10.9)	
27.	110-253	4	POP RIVET (3/16" X 1/2")	
28.	105-117	6	WASHER 5/16")	
29.	106-561	6	LOCKNUT (M8-1.25, PRV TRQ, 10.9)	
30.	106-391	4	WASHER (M12)	
31.	116-789	AR	RUBBER EDGE TRIM (1/8", SOLD PER FT.)	USE I @ 15", SEE FOOTNOTE 1
32.	106-469	2	SCREW (M12-1.75 X 30mm)	

NOT SHOWN:

FOOTNOTES:

1. START EDGING 8" FROM END OF TANK AND USE LOCTITE 401.

NOTE:

2-POST ROPS

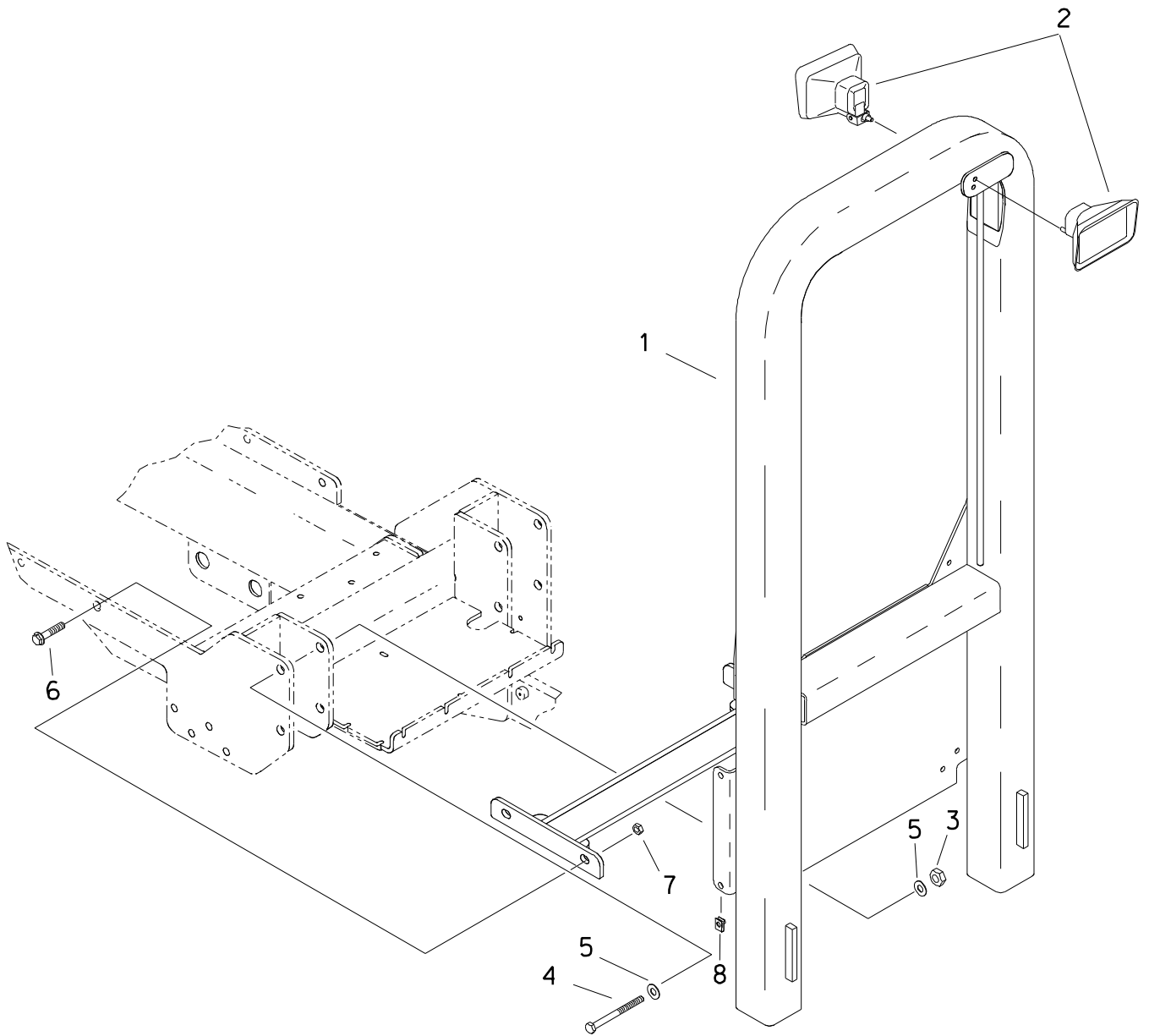

2-POST ROPS

REF NO.	PART NUMBER	QTY	DESCRIPTION	REMARKS
1.	309-190	1	2-POST ROPS	
2.	217-057	-	WORKING LIGHT - CLEAR	
-	105-033	1	BOLT (5/16-NC X 2")	
-	105-091	2	LOCK WASHER (5/16")	
-	105-092	2	NUT (5/16-NC)	
3.	106-665	4	LOCKNUT (M20-2.50, 10.9)	
4.	106-373	4	SCREW (M20-2.5 X 160mm)	
5.	106-399	8	WASHER (M20, HARDENED)	
6.	106-470	4	FLG SCREW (M16-2.00 X 40mm)	
7.	106-545	4	LOCKNUT (M16-2.00, PRV TRQ, 10.9)	
8.	107-687	4	CLIP NUT M8-1.25, LONG, WIDE	

FOOTNOTES

DRILLFRAME COVERS/LCKS/SWITCHES

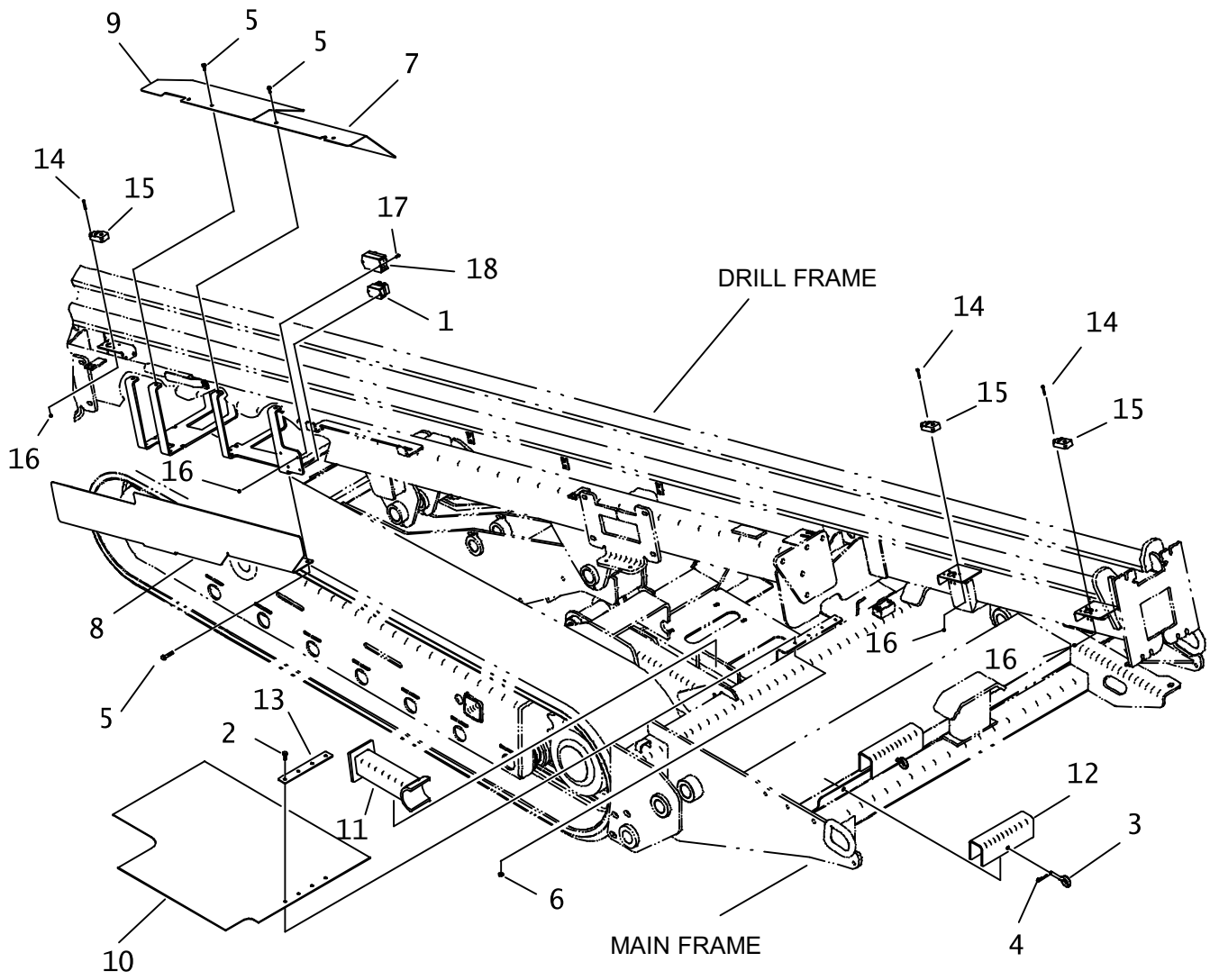

DRILLFRAME COVERS/LCKS/SWITCHES

REF NO.	PART NUMBER	QTY	DESCRIPTION	REMARKS
1.	211-026	1	DIODE PACK (DEUTSCH)	
2.	106-162	4	FLG SCREW (M8-1.25 X 20MM)	
3.	110-034	2	EYE PIN (7/16" X 3")	
4.	110-033	2	HAIR CLIP PIN (1/8" X ")	
5.	106-991	8	FLG LK SCREW (M8-1.25 X 20MM)	
6.	106-561	4	LOCKNUT (M8-1.25, PRV TRQ, 10.9)	
7.	305-948	1	VALVE COVER	
8.	305-949	1	VALVE COVER	
9.	305-947	1	VALVE COVER	
10.	116-863	1	COVER FLAP	
11.	354-562	1	DRILL FRAME STIFF LEG	
12.	354-980	2	CYLINDER LOCK	
13.	350-514	1	CLAMP PLATE	
14.	107-465	6	SCREW (M5-0.80 X 30MM, SOC)	
15.	215-1175	3	PROXIMITY SWITCH	
16.	106-850	10	LOCKNUT (M5-0.80)	
17.	106-542	4	SCREW (M5-0.80X16MM, PAN PLPS)	
18.	211-025	-	IN-LINE DIODE PACK	

NOT SHOWN:

107-451 AR SHIM (.135")
213-103 AT/JT42M1 REAR STOP HARNESS

FOOTNOTES:

NOTE:

HOSE RETAINING CLAMP

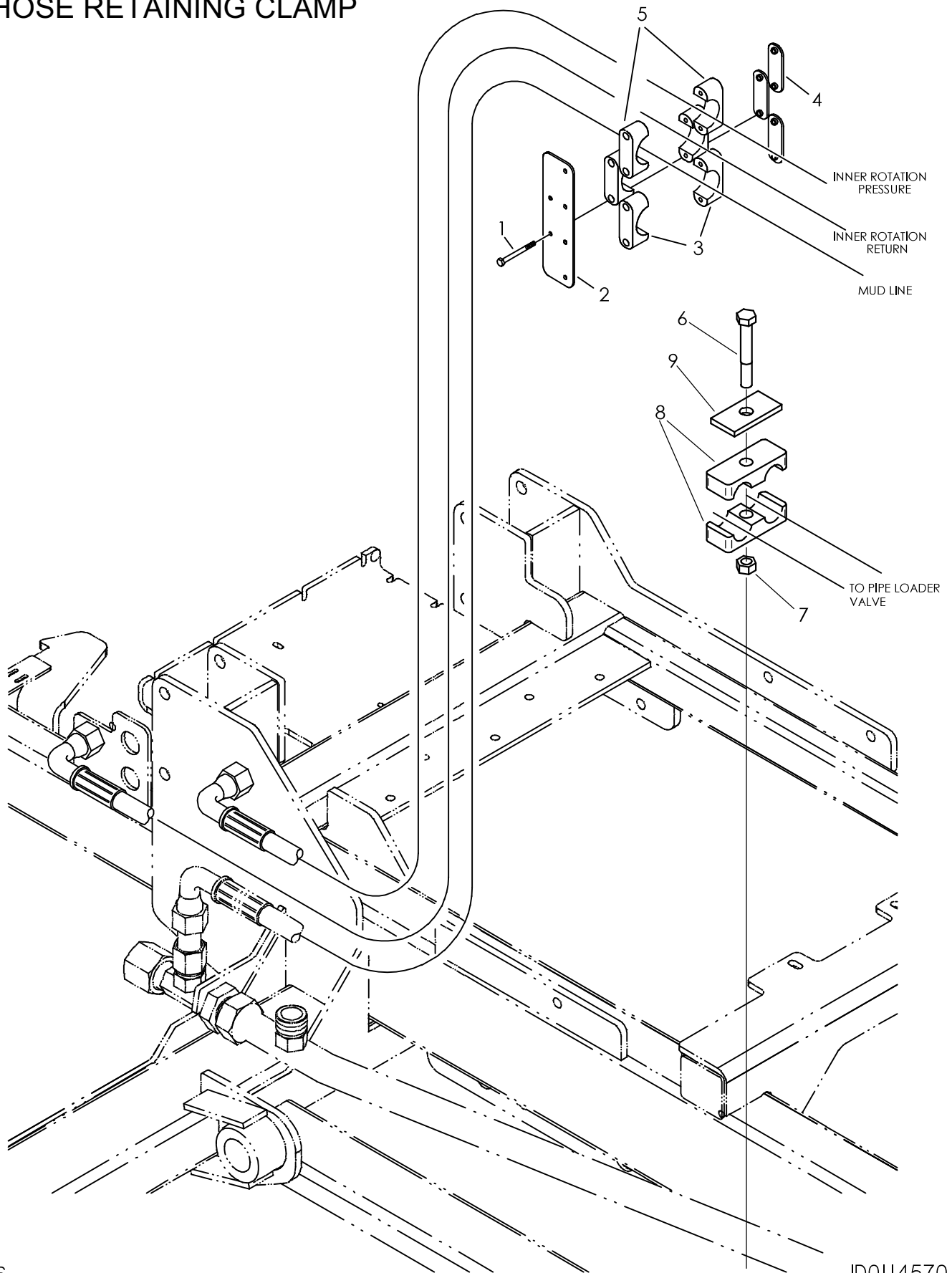

HOSE RETAINING CLAMP

REF NO.	PART NUMBER	QTY	DESCRIPTION	REMARKS
1.	107-743	6	SCREW (1/4-NC X 2.75", GD 5)	
2.	314-794	1	PLATE	
3.	110-970	2	CLAMP (2.00")	
4.	110-972	3	WELD PLATE	
5.	111-010	1	BLT-ON CLAMP(1.750", SET)	
6.	106-570	1	SCREW (M8-1.25 X 60MM)	FOOTNOTE I
7.	106-561	1	LOCKNUT (M8-1.25 PRV TRQ, 10.9)	FOOTNOTE I
8.	110-195	2	BOLT-ON CLAMP (3/4", PER HALF)	FOOTNOTE I
9.	305-256	1	BACKUP SPACER	FOOTNOTE I

NOT SHOWN:

FOOTNOTES:

- I. USE WITH RACK & PINION UNITS ONLY

NOTE:

NOTES:

ANCHOR SYSTEMS

AUGER ANCHOR BASE

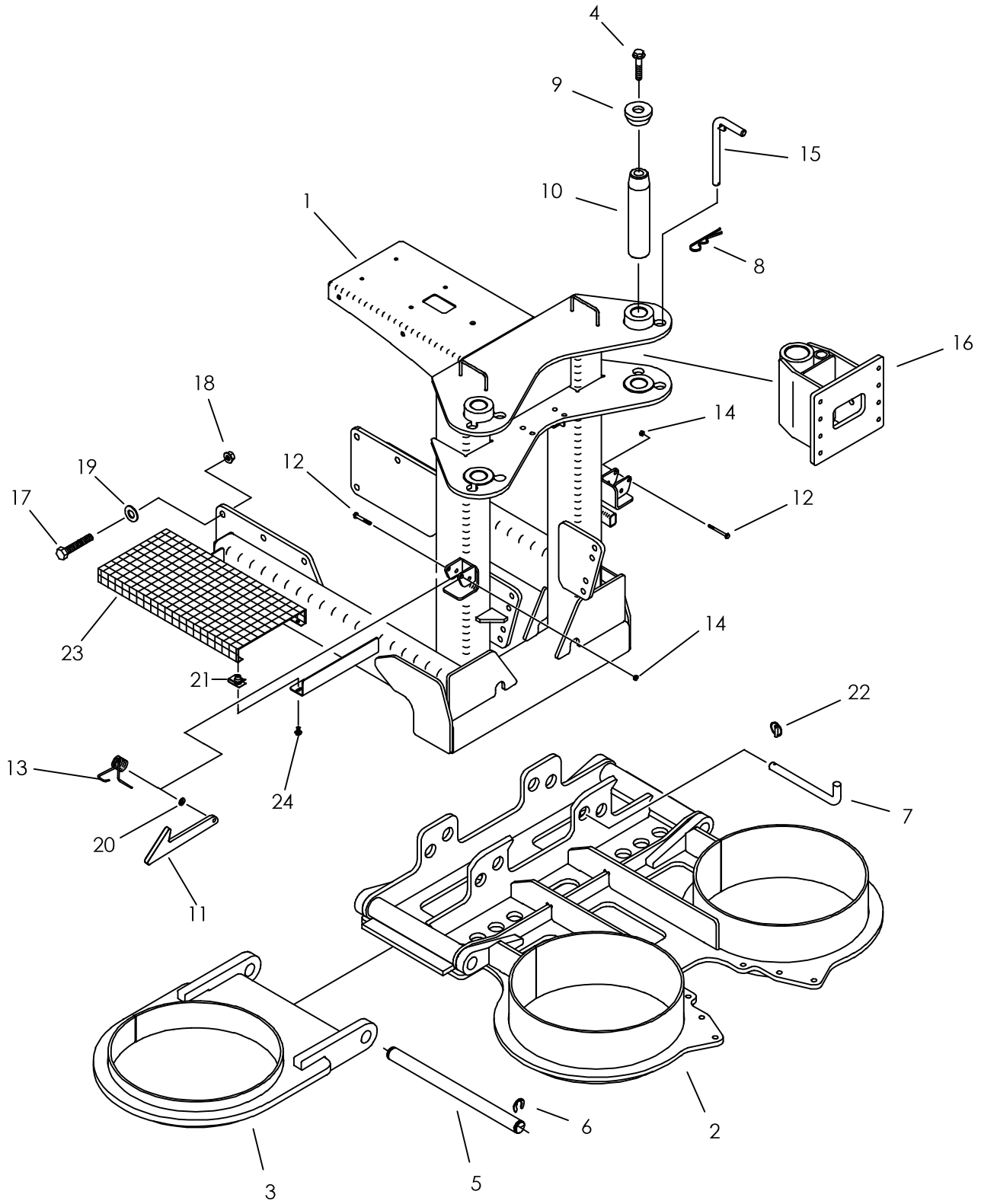

AUGER ANCHOR BASE

REF NO.	PART NUMBER	QTY	DESCRIPTION	REMARKS
1.	310-362	-	ANCHOR ATTACHMENT FRAME	
	327-1059	-	ANCHOR ATTACHMENT FRAME	SEE FOOTNOTE I
2.	313-592	1	ANCHOR BASE	
3.	343-548	2	PIVOT	
4.	106-470	2	FLG SCREW (M16-2.00 X 40mm)	
5.	184-973	2	PIN	
6.	115-483	4	KLIP RING (1.25")	
7.	343-445	2	PIN (31.75MM X 262MM)	
8.	110-128	2	SPRING CLIP PIN (5/32" X 1")	
9.	181-975	2	TAPERED INSERT (1.75")	
10.	179-239	2	TAPERED PIN (44.4mm X 288mm)	
11.	350-371	2	LATCH	
12.	106-332	4	SCREW (M10-1.50 X 70mm)	
13.	115-580	2	TORSION SPRING	
14.	105-894	4	LOCKNUT (M10-1.50, PRV TRQ, 10.9)	
15.	350-516	2	PIN	
16.	309-209	2	ARM	
17.	106-798	8	SCREW (M20-2.50 X 55MM, 10.9)	USE LOC TITE 242
18.	106-356	8	FLG LOCKNUT (M20-2.50, 10.9, PRV TRQ)	
19.	106-399	8	WASHER (M20, HARDENED)	
20.	105-884	6	WASHER (.531")	
21.	106-551	4	CLIP NUT (M8-1.25)	
22.	110-228	2	LYNCH PIN (7/16" X 2")	
23.	350-989	1	FLOOR TREADS	
24.	106-991	4	FLG LK SCREW (M8-1.25 X 20MM)	

NOT SHOWN:

FOOTNOTES:

I. USE ON 4020 WITH RACK AND PINION

NOTE:

ANCHOR VALVE & COVER MOUNT

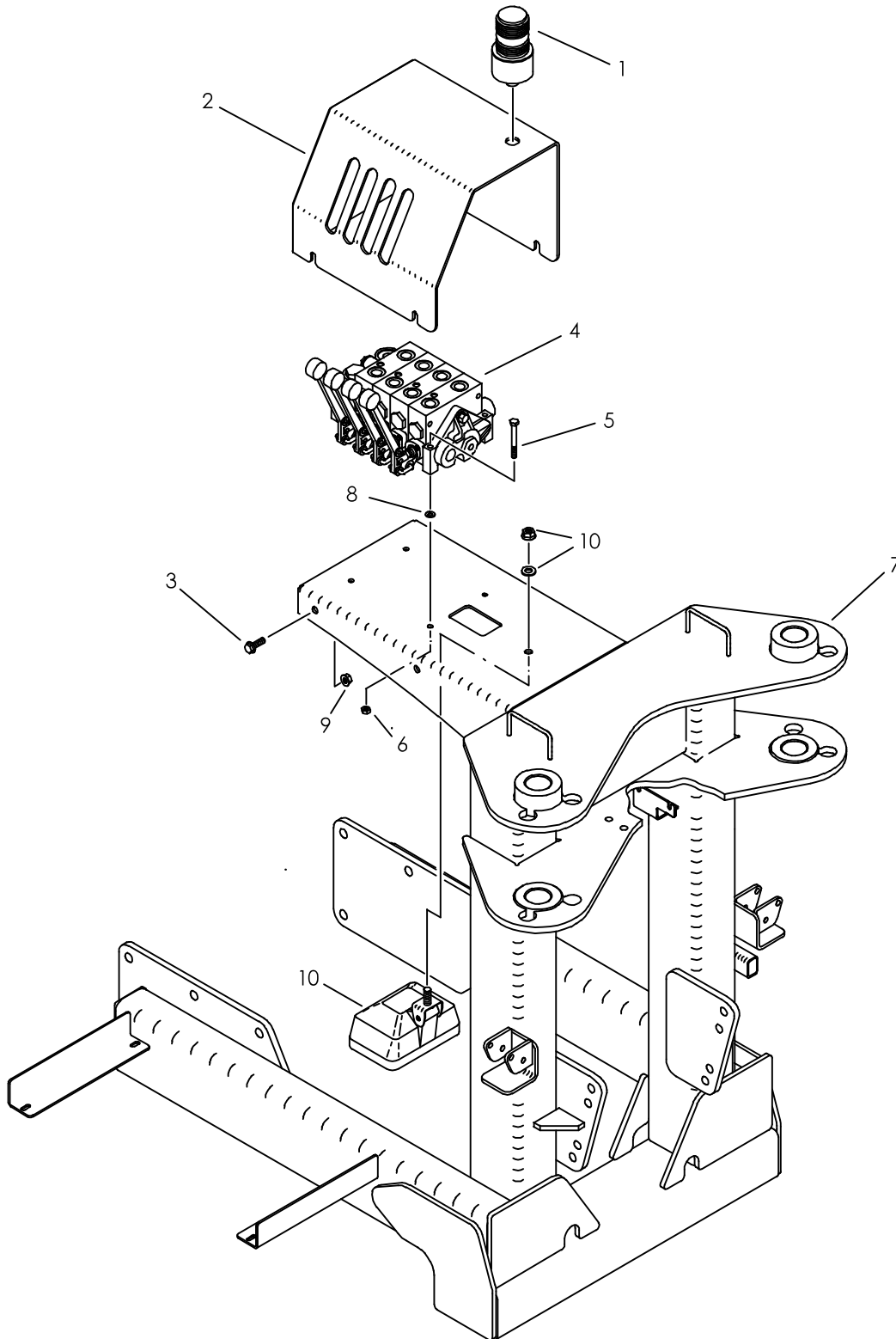

ANCHOR VALVE & COVER MOUNT

REF NO.	PART NUMBER	QTY	DESCRIPTION	REMARKS
1.	214-697	-	STROBE LIGHT (12V, DC, GREEN)	INSTALL ELECTRICAL PLUG AFTER MOUNTING LIGHT
	217-297	-	STROBE LIGHT GREEN MED PROFILE	
	214-103	1	2-WAY MALE CONNECTOR	
	214-991	-	REPLACEMENT FLASH TUBE	
	217-303	-	REPLACEMENT LENS (GREEN)	
	157-645	2	WEATHER-PAC SEAL (2.80MM)	
	214-104	2	PACKARD MALE TERMINAL	
	217-301	-	BRUSH GUARD	
2.	309-254	1	VALVE COVER	
3.	106-383	4	FLG LK SCREW (M10-1.50 X 30MM)	
4.	149-952	-	HYD CONTROL VALVE (4-SPOOL)	SEE FOOTNOTE I
5.	106-330	3	SCREW (M8-1.25 X 70MM)	
6.	106-561	3	LOCKNUT (M8-1.25,PRV TRQ,10.9)	
7.	310-362	-	ANCHOR ATTACHMENT FRAME	
	327-1059	-	ANCHOR ATTACHMENT FRAME	
8.	106-389	3	WASHER (M8)	
9.	106-387	4	FLG LOCKNUT (M10-1.50)	
10.	217-007	1	WORKING LIGHT (CLEAR, RECT)	

NOT SHOWN:

FOOTNOTES:

I. USE ON 4020 WITH RACK AND PINION.

NOTE:

FRONT PIPE GUIDE. ALL TERRAIN ONLY

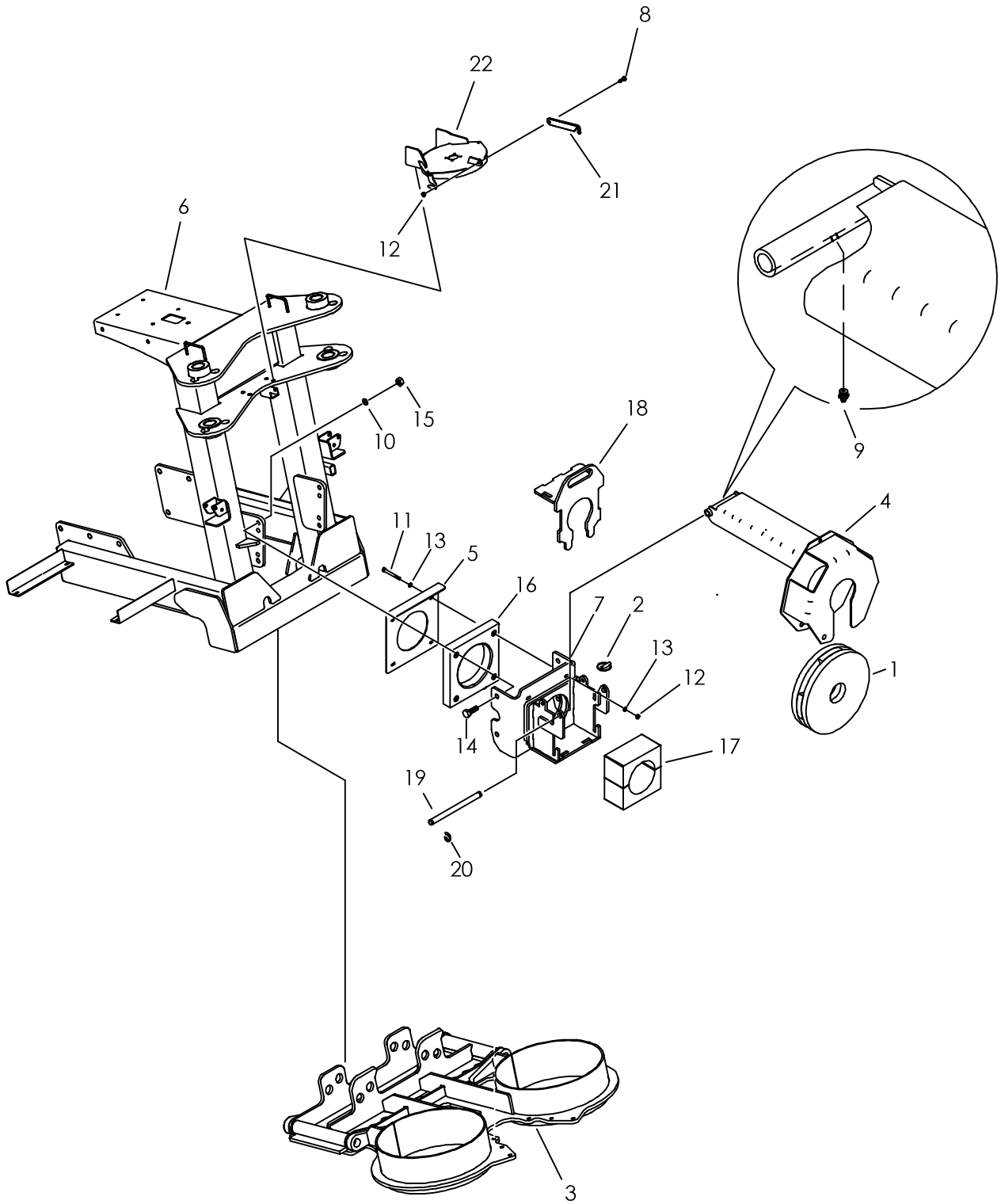

FRONT PIPE GUIDE. ALL TERRAIN ONLY

REF NO.	PART NUMBER	QTY	DESCRIPTION	REMARKS
1.	157-196	1	ROD WIPER	
2.	110-228	2	LYNCH PIN (7/16" X 2")	
3.	313-592	1	ANCHOR BASE	
4.	314-732	1	WIPER MOUNT	
5.	310-366	1	COVER	
6.	310-362	1	ANCHOR ATTACHMENT FRAME	
	327-1059	1	ANCHOR ATTACHMENT FRAME	SEE FOOTNOTE I
7.	319-747	1	GUIDE BEARING MOUNT	
8.	106-381	1	FLG LK SCREW (M8-1.25 X 25MM)	
9.	115-003	1	ZERK (1/4-NF, STR)	
10.	106-397	4	WASHER (M12, HARDENED)	
11.	106-602	4	SCREW (M8-1.25 X 80MM)	
12.	106-561	5	LOCKNUT (M8-1.25, PRV TRQ, 10.9)	
13.	105-117	8	WASHER (5/16")	
14.	107-307	4	BOLT (M12-1.75 X 45MM)	
15.	106-685	4	LOCKNUT (M12-1.75, PRV TRQ, 10.9)	
16.	211-084	1	CURRENT TRANSFORMER	
17.	314-359	2	GUIDE BLOCK (4.13)	
18.	314-387	1	BLOCK RETAINER	
19.	178-863	1	PIVOT PIN	
20.	115-503	2	KLIP RING (.750")	
21.	314-744	1	HOOK	
22.	350-400	-	COVER	

NOT SHOWN:

214-542	CURRENT COIL CABLE
211-042	VOLTAGE LIMITER
215-799	VOLTAGE STAKE

FOOTNOTES:

I. USE ON 4020 WITH RACK AND PINION. USE UPPER SET OF HOLES TO MOUNT 319-747.

NOTE:

FRONT PIPE GUIDE

JT 4020 MACH 1 ONLY

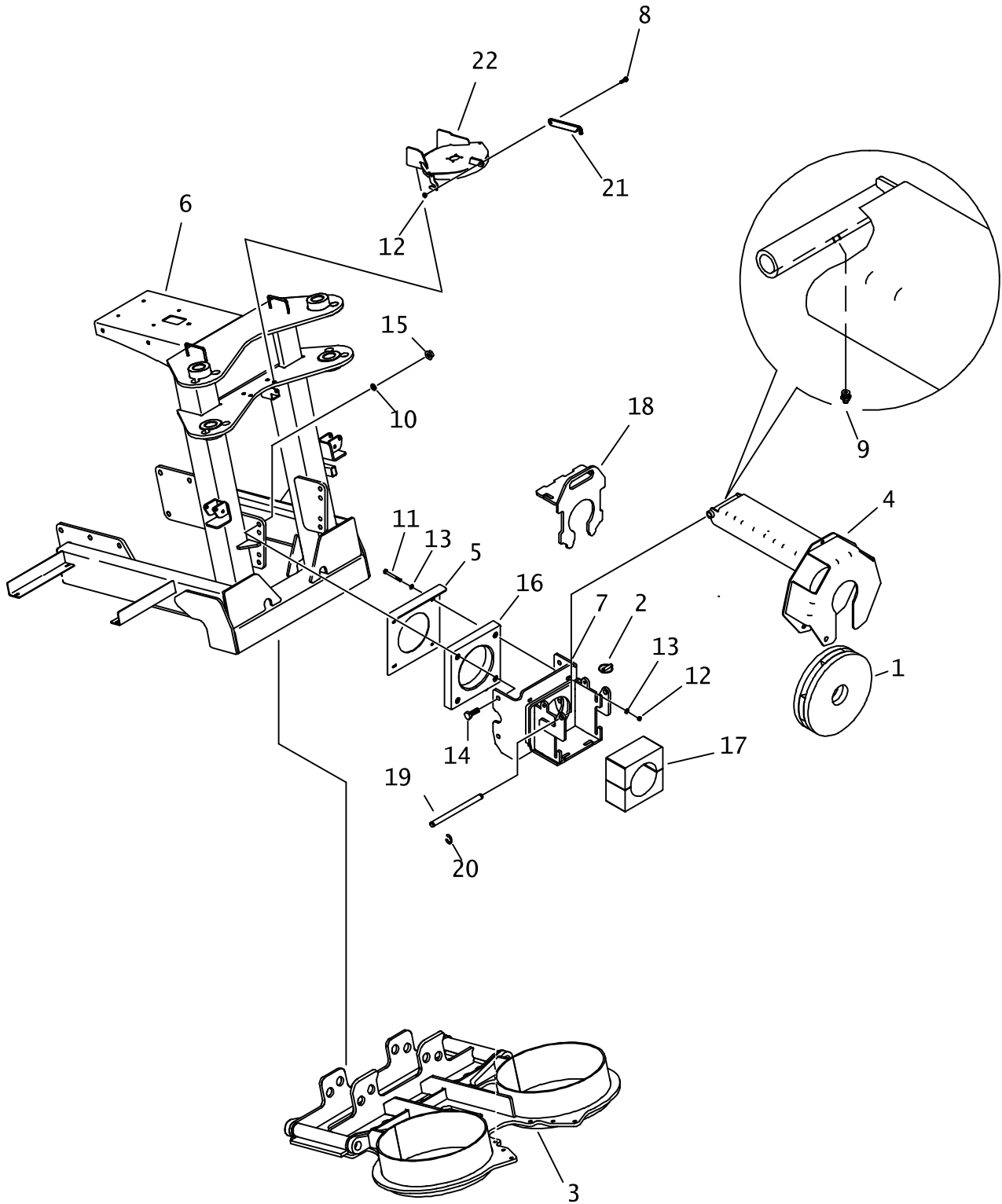

FRONT PIPE GUIDE JT 4020 MACH 1 ONLY

REF NO.	PART NUMBER	QTY	DESCRIPTION	REMARKS
1.	117-627	1	ROD WIPER	
2.	110-228	2	LYNCH PIN (7/16" X 2")	
3.	313-592	1	ANCHOR BASE	
4.	314-732	1	WIPER MOUNT	
5.	310-366	1	COVER	
6.	310-362	1	ANCHOR ATTACHMENT FRAME	
	327-1059	1	ANCHOR ATTACHMENT FRAME	SEE FOOTNOTE I
7.	319-747	1	GUIDE BEARING MOUNT	
8.	106-381	1	FLG LK SCREW (M8-1.25 X 25MM)	
9.	115-003	1	ZERK (1/4-NF, STR)	
10.	106-397	4	WASHER (M12, HARDENED)	
11.	106-602	4	SCREW (M8-1.25 X 80MM)	
12.	106-561	5	LOCKNUT (M8-1.25, PRV TRQ, 10.9)	
13.	105-117	8	WASHER (5/16")	
14.	107-307	4	BOLT (M12-1.75 X 45MM)	
15.	106-685	4	LOCKNUT (M12-1.75, PRV TRQ, 10.9)	
16.	211-084	1	CURRENT TRANSFORMER	
17.	314-360	2	GUIDE BLOCK (3.50)	
18.	314-387	1	BLOCK RETAINER	
19.	178-863	1	PIVOT PIN	
20.	115-503	2	KLIP RING (.750")	
21.	314-744	1	HOOK	
22.	350-400	-	COVER	

NOT SHOWN:

214-542	CURRENT COIL CABLE
211-042	VOLTAGE LIMITER
215-799	VOLTAGE STAKE

FOOTNOTES:

USE ON 4020 WITH RACK AND PINION.

NOTE:

RIGHT AUGER ANCHOR DRIVE

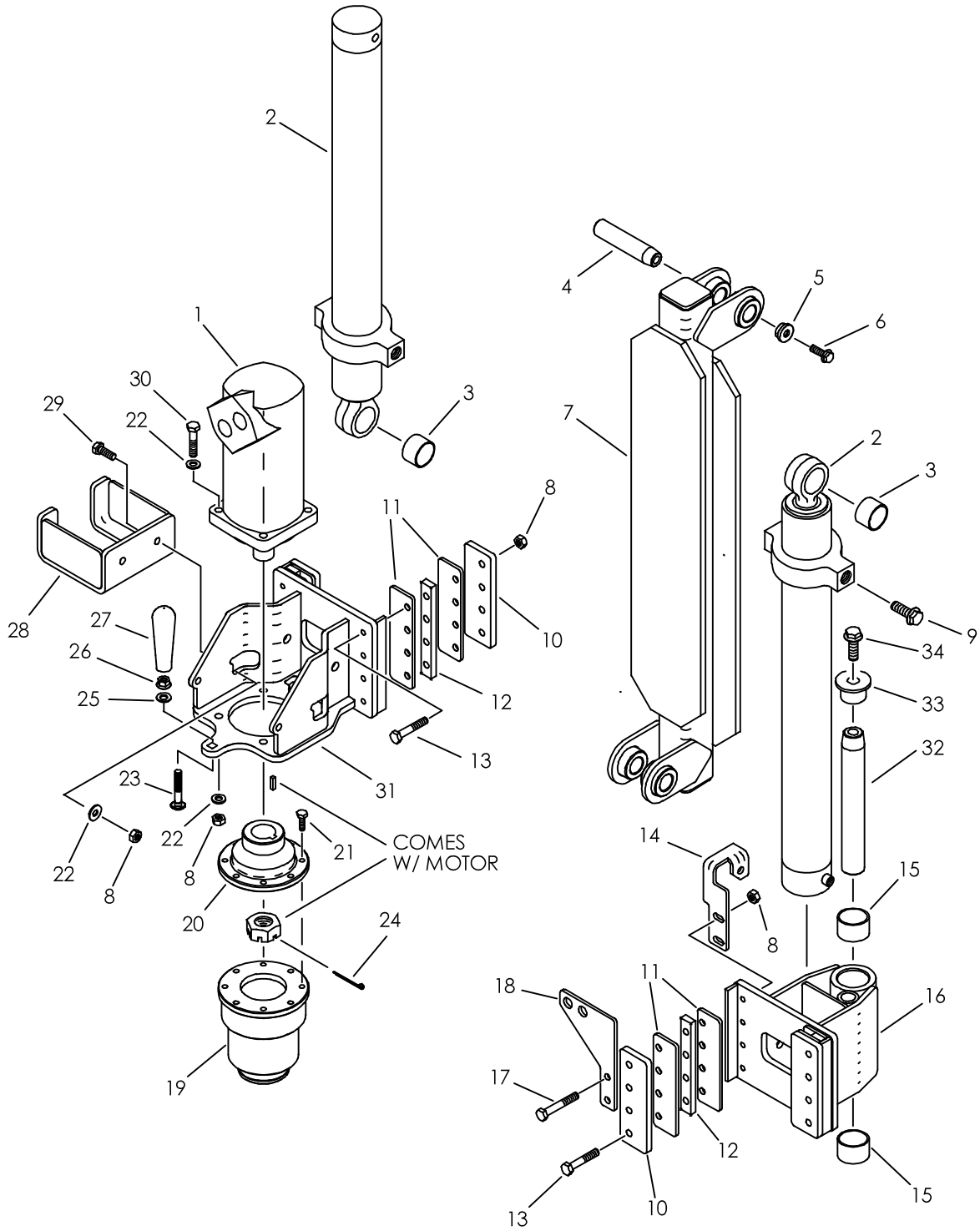

RIGHT AUGER ANCHOR DRIVE

REF NO.	PART NUMBER	QTY	DESCRIPTION	REMARKS
1.	149-895	1	HYD MOTOR	
	500-390		SEAL REPAIR KIT - REAR	
	500-391		SEAL REPAIR KIT - SHAFT	
	502-177		SHAFT AND BEARING ASS'Y	
	107-792		BOLT (5/16"X 1-5/8", DBL HEX)	
	165-900		KEY (7/16" SQ X 1.250")	
	105-917		CASTLE NUT (1-1/4-NF)	SEE FOOTNOTE 1
	500-2123		FRONT RETAINER (ANCHOR MOTOR)	
2.	150-747	2	CYLINDER ASSEMBLY	
3.	125-771	2	COMPOSITION BUSHING (1.25")	
4.	183-765	2	TAPERED PIN (31.7MM X 110MM)	
5.	181-982	2	TAPERED INSERT (1.25")	
6.	106-469	2	FLG SCREW (M12-1.75 X 30MM)	USE LOCTITE 242
7.	359-799	1	MAST	
8.	106-685	23	LOCKNUT(M12-1.75,PRV TRQ,10.9)	
9.	106-471	4	FLG SCREW (M16-2.00 X 30MM)	USE LOCTITE 242
10.	309-194	4	CLAMP PLATE	
11.	309-195	8	GLIDE STRIP	
12.	309-203	4	CARRIAGE SPACER BAR	
13.	106-335	14	SCREW (M12-1.75 X 70MM)	
14.	309-205	1	BULKHEAD PLATE	
15.	125-773	2	COMPOSITION BUSHING (1.75")	
16.	309-209	1	ARM	
17.	106-700	2	SCREW (M12-1.75 X 80MM)	
18.	309-204	1	BULKHEAD PLATE	
19.	309-582	-	FLANGED HEX DRIVER	
20.	178-881	1	FLANGE	
21.	105-245	8	SCREW (M10-1.50 X 25MM)	USE LOCTITE 242
22.	106-397	9	WASHER (M12, HARDENED)	
23.	105-279	1	CARRIAGE BOLT (1/2-NC X 3")	
24.	105-501	1	COTTER PIN (1/8" X 2")	
25.	105-071	1	WASHER (1/2")	
26.	105-833	1	FLG LOCKNUT (1/2-NC)	
27.	110-531	1	HANDLE (1/2-NC, BLACK)	USE LOCTITE 242
28.	309-602	1	ANCHOR HANGER	
29.	106-333	2	SCREW (M12-1.75 X 40MM, 8.8)	
30.	106-594	4	SCREW (M12-1.75 X 60MM)	
31.	309-207	1	MOTOR MOUNT	
32.	179-239	1	TAPERED PIN (44.4MM X 288MM)	
33.	181-975	1	TAPERED INSERT (1.75")	
34.	106-470	1	FLG SCREW (M16-2.00 X 40MM)	USE LOCTITE 242

NOT SHOWN:

FOOTNOTES:

- I. TORQUE NUT TO 375 FT. LB. DRY OR 275 FT. LB. LUBED

NOTE:

LEFT AUGER ANCHOR DRIVE

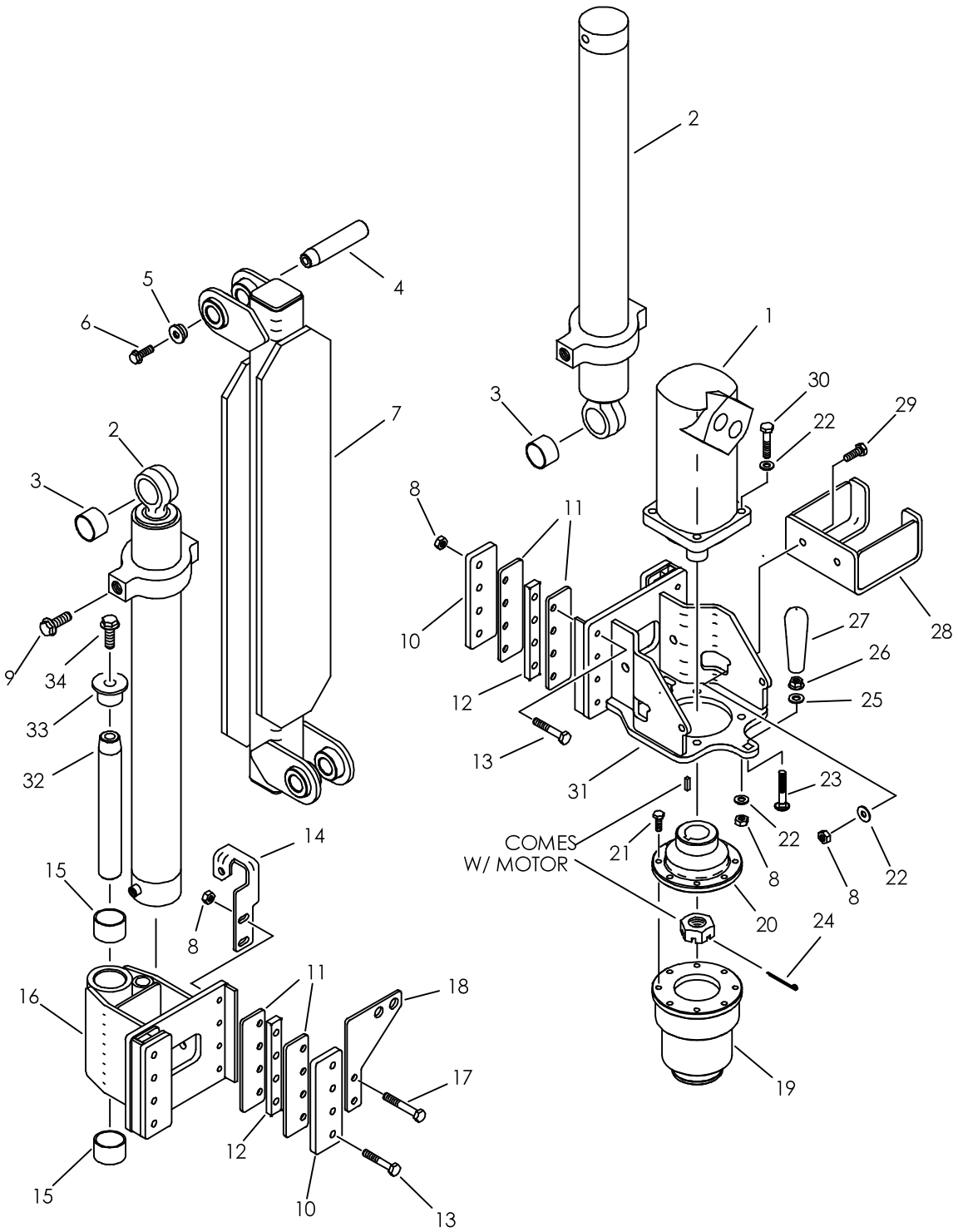

LEFT AUGER ANCHOR DRIVE

REF NO.	PART NUMBER	QTY	DESCRIPTION	REMARKS
1.	149-895	1	HYD MOTOR	
	500-390		SEAL REPAIR KIT - REAR	
	500-391		SEAL REPAIR KIT - SHAFT	
	502-177		SHAFT AND BEARING ASS'Y	
	107-792		BOLT (5/16" X 1-5/8", DBL HEX)	
	165-900		KEY (7/16" SQ X 1.250")	
	105-917		CASTLE NUT (1-1/4-NF)	SEE FOOTNOTE 1
	500-2123		FRONT RETAINER (ANCHOR MOTOR)	
2.	150-747	2	CYLINDER ASSEMBLY	
3.	125-771	2	COMPOSITION BUSHING (1.25")	
4.	183-765	2	TAPERED PIN (31.7MM X 110MM)	
5.	181-982	2	TAPERED INSERT (1.25")	
6.	106-469	2	FLG SCREW (M12-1.75 X 30MM)	USE LOCTITE 242
7.	359-799	1	MAST	
8.	106-685	23	LOCKNUT(M12-1.75,PRV TRQ,10.9)	
9.	106-471	4	FLG SCREW (M16-2.00 X 30MM)	USE LOCTITE 242
10.	309-194	4	CLAMP PLATE	
11.	309-195	8	GLIDE STRIP	
12.	309-203	4	CARRIAGE SPACER BAR	
13.	106-335	14	SCREW (M12-1.75 X 70MM)	
14.	309-206	1	BULKHEAD PLATE	
15.	125-773	2	COMPOSITION BUSHING (1.75")	
16.	309-209	1	ARM	
17.	106-700	2	SCREW (M12-1.75 X 80MM)	
18.	309-204	1	BULKHEAD PLATE	
19.	309-582	-	FLANGED HEX DRIVER	
20.	178-881	1	FLANGE	
21.	105-245	8	SCREW (M10-1.50 X 25MM)	USE LOCTITE 242
22.	106-397	9	WASHER (M12, HARDENED)	
23.	105-279	1	CARRIAGE BOLT (1/2-NC X 3")	
24.	105-501	1	COTTER PIN (1/8" X 2")	
25.	105-071	1	WASHER (1/2")	
26.	105-833	1	FLG LOCKNUT (1/2-NC)	
27.	110-531	1	HANDLE (1/2-NC, BLACK)	USE LOCTITE 242
28.	309-602	1	ANCHOR HANGER	
29.	106-333	2	SCREW (M12-1.75 X 40MM, 8.8)	
30.	106-594	4	SCREW (M12-1.75 X 60MM)	
31.	309-207	1	MOTOR MOUNT	
32.	179-239	1	TAPERED PIN (44.4MM X 288MM)	
33.	181-975	1	TAPERED INSERT (1.75")	
34.	106-470	1	FLG SCREW (M16-2.00 X 40MM)	USE LOCTITE 242

NOT SHOWN:

FOOTNOTES:

1. TORQUE NUT TO 375 FT. LB. DRY OR 275 FT. LB. LUBED

NOTE:

FLANGED HEX DRIVER ASS'Y

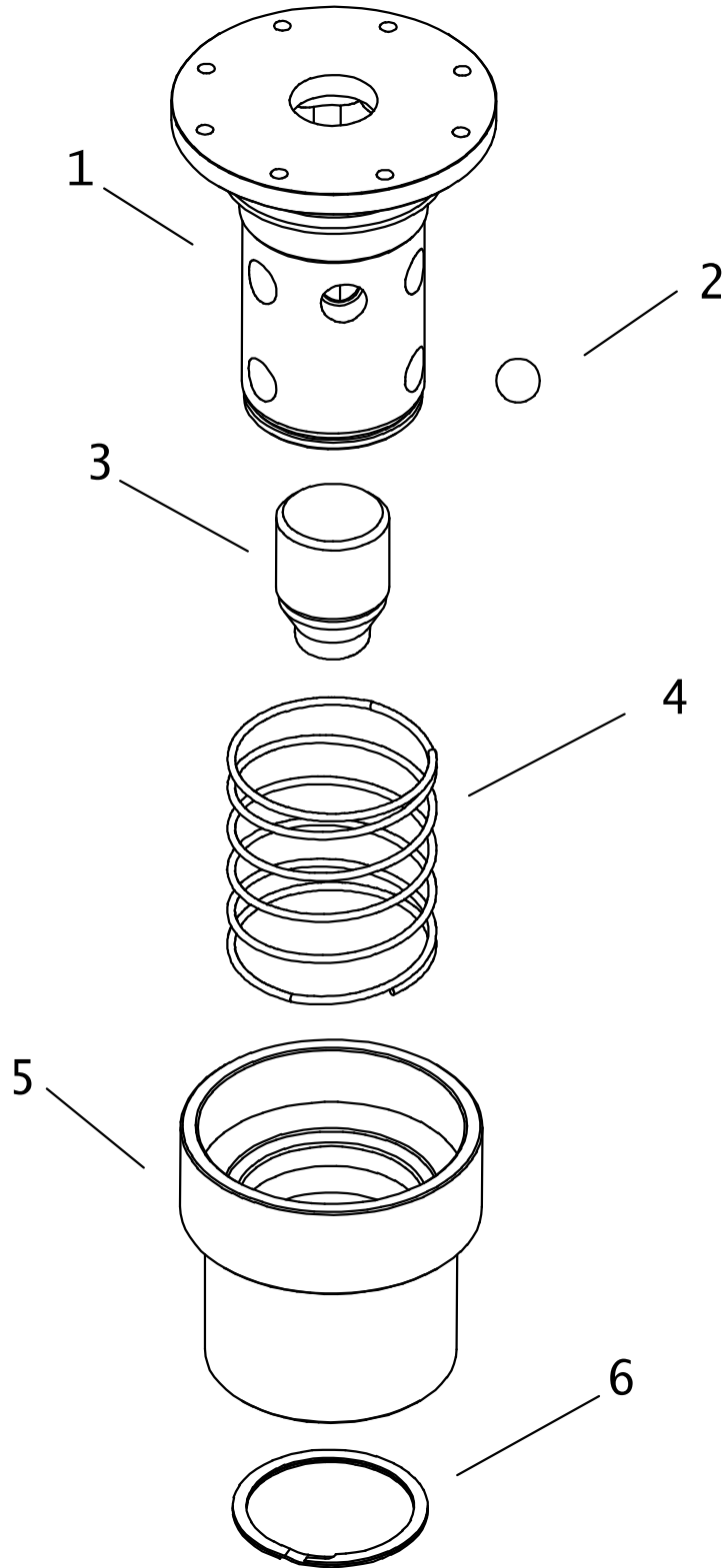

FLANGED HEX DRIVER ASS'Y

REF NO.	PART NUMBER	QTY	DESCRIPTION	REMARKS
	309-582		FLANGED HEX DRIVER	INCLUDEDS REF NO. 1-6
1.	309-093	1	ANCHOR DRIVER	FOOTNOTE 2
2.	125-150	9	DETENT BALL (.875")	
3.	309-095	1	WEIGHT STOP	
4.	117-160	1	COMPRESSION RING	
5.	178-591	1	LOCK COLLAR	
6.	118-054	1	EXTERNAL SNAP RING	
	116-761	1	SPIRAL RETAINING RING	FOOTNOTE 1

NOT SHOWN:

FOOTNOTES:

1. USE WHEN INSTALLING UPDATED 309-093
2. UPDATED VERSION NECKED-DOWN FOR THICKER 116-761

NOTE:

ANCHOR

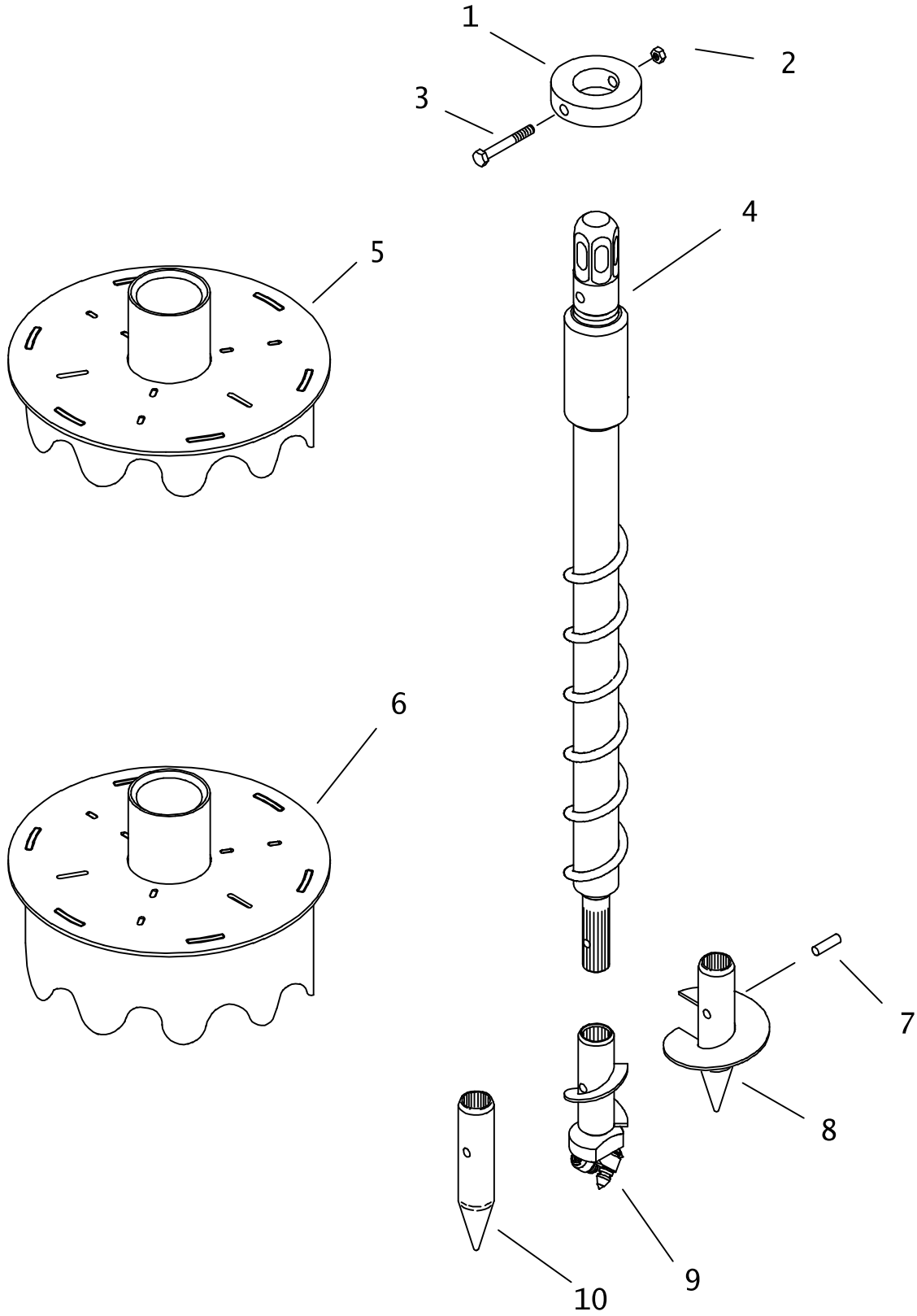

ANCHOR

REF NO.	PART NUMBER	QTY	DESCRIPTION	REMARKS
	309-250	-	ANCHOR SHAFT	INCL REF NO'S 1-4
1.	178-513	1	COLLAR	
2.	106-685	1	LOCKNUT(M12-1.75,PRV TRQ,10.9)	
3.	106-645	1	SCREW (M12-1.75 X 110MM, 10.9)	
4.	308-902	1	ANCHOR STAKE	
5.	309-750	1	CENTERING CAP	SHORT - USED IN SIDE POSITIONS
6.	308-903	1	CENTERING CAP	TALL - USED IN FRONT POSITIONS
7.	183-860	AR	ROLL PIN (1/2" X 1-7/8")	
8.	356-366	AR	AUGER (150MM}	
	356-365	AR	AUGER (225MM)	
	356-364	AR	AUGER (380MM)	
9.	369-438	AR	3.5" CAP ANCHOR BIT	ROCK BITS
	136-113	-	INSERT BIT - CARBIDE TIPPED	REPLACEMENT BIT FOR 369-438
	131-259	-	INSERT BIT- CARBIDE TIPPED	
	136-112	-	CLIP RETAINER	REPLACEMENT CLIP FOR 369-438
10.	357-330	AR	STAKE POINT	DIRT BITS

NOT SHOWN:

FOOTNOTES:

NOTE:

LUBRICATOR SYSTEMS

GREASE PUMP MOUNTING

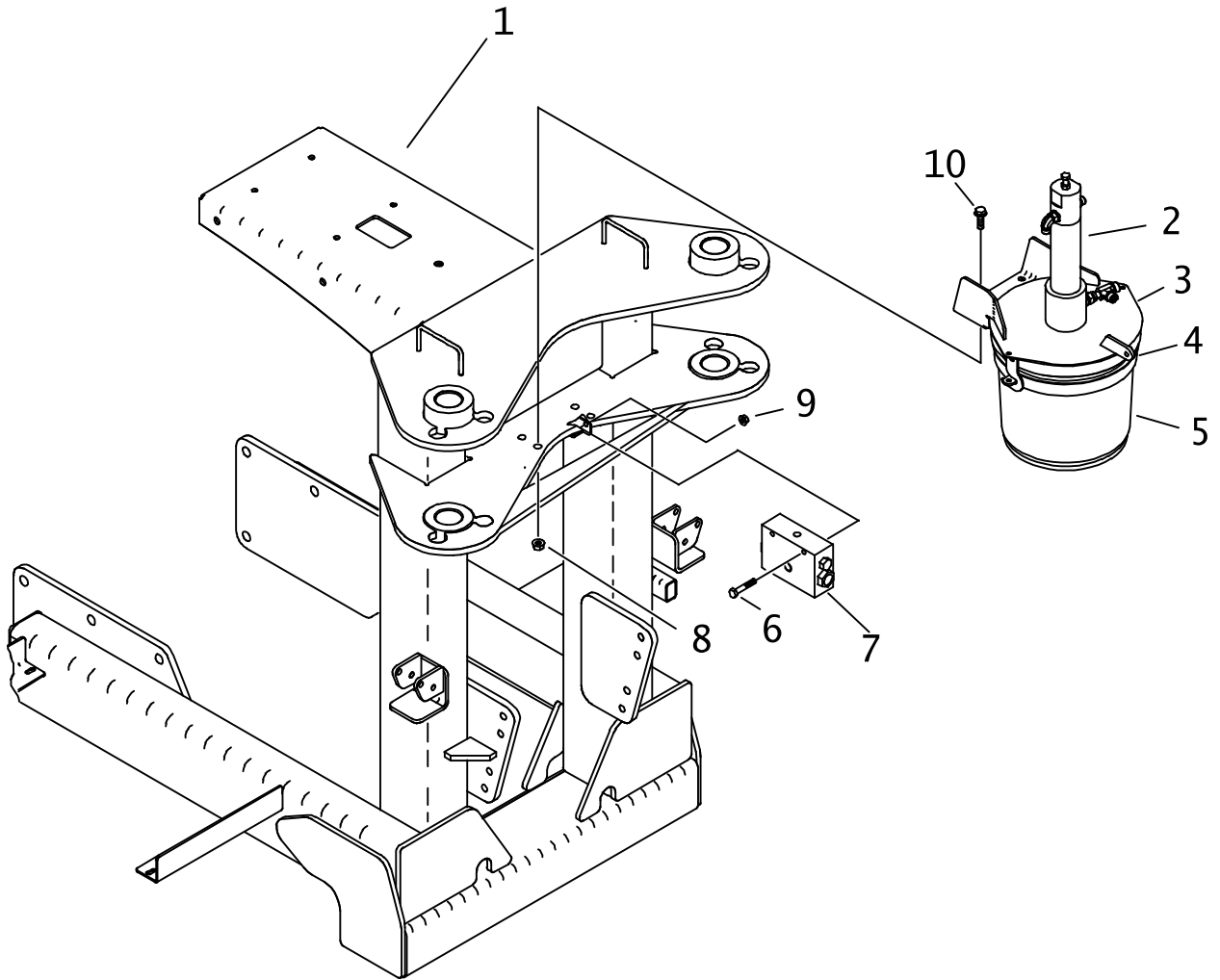

GREASE PUMP MOUNTING

REF NO.	PART NUMBER	QTY	DESCRIPTION	REMARKS
1.	310-362	-	ANCHOR ATTACHMENT FRAME	
	327-1059	-	ANCHOR ATTACHMENT FRAME	SEE FOOTNOTE I
2.	350-398	-	GREASE PUMP	
3.	350-400	-	COVER	
4.	350-399	-	BASE	
5.	259-858	-	TOOL JNT LUBE, STD SPRY 2 GAL	USE BELOW 80 DEG F MAX TEMP
	256-031	-	TOOL JNT LUBE, SUMR SPRY 2 GAL	USE ABOVE 50 DEG F MIN TEMP
6.	106-570	2	SCREW (M8-1.25 X 60MM)	
7.	310-591	1	VALVE ASS'Y	
8.	106-387	4	FLG LOCKNUT (M10-1.50)	
9.	106-386	2	FLG LOCKNUT (M8-1.25)	
10.	106-383	4	FLG LK SCREW (M10-1.50 X 30MM)	

NOT SHOWN:

FOOTNOTES:

USE ON 4020 WITH RACK AND PINION

NOTE:

AUTO-LUBER ASSEMBLY

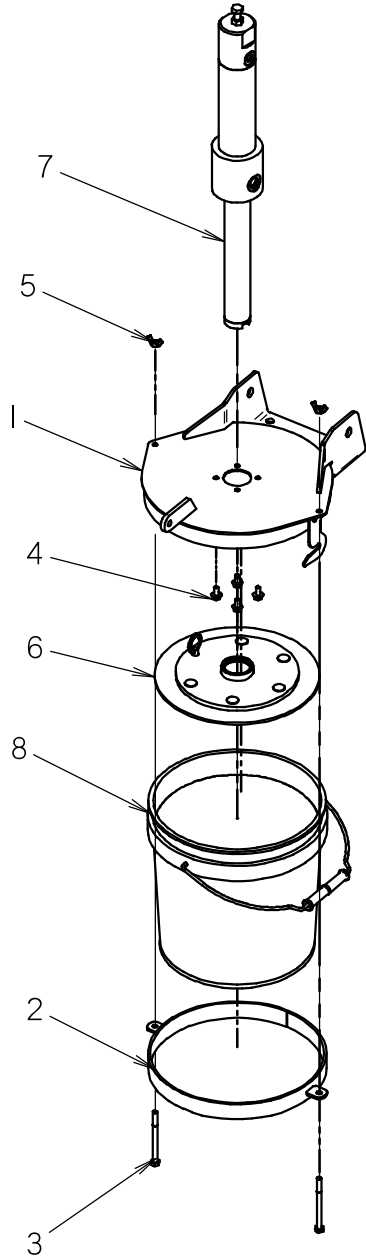

AUTO-LUBER ASSEMBLY

REF NO.	PART NUMBER	QTY	DESCRIPTION	REMARKS
1	350-400	1	COVER WELDMENT	
2	350-399	1	BASE	
3	105-297	2	BOLT (1/4-NC X 3-1/4")	
4	106-378	4	FLG LK SCREW (M6-1.00 X 12MM)	
5	195-339	2	WING NUT (1/4-NC)	
6	350-1932	1	TOOL JOINT LUBE FOLLOWER	
7	350-398	1	GREASE PUMP PARTS	
8	259-858	1	TOOL JNT LUBE, STD SPRY 2 GAL	
	256-031	-	TOOL JNT LUBE, SUMR SPRY 2 GAL	

NOT SHOWN:

FOOTNOTES:

NOTE:

GREASE PUMP

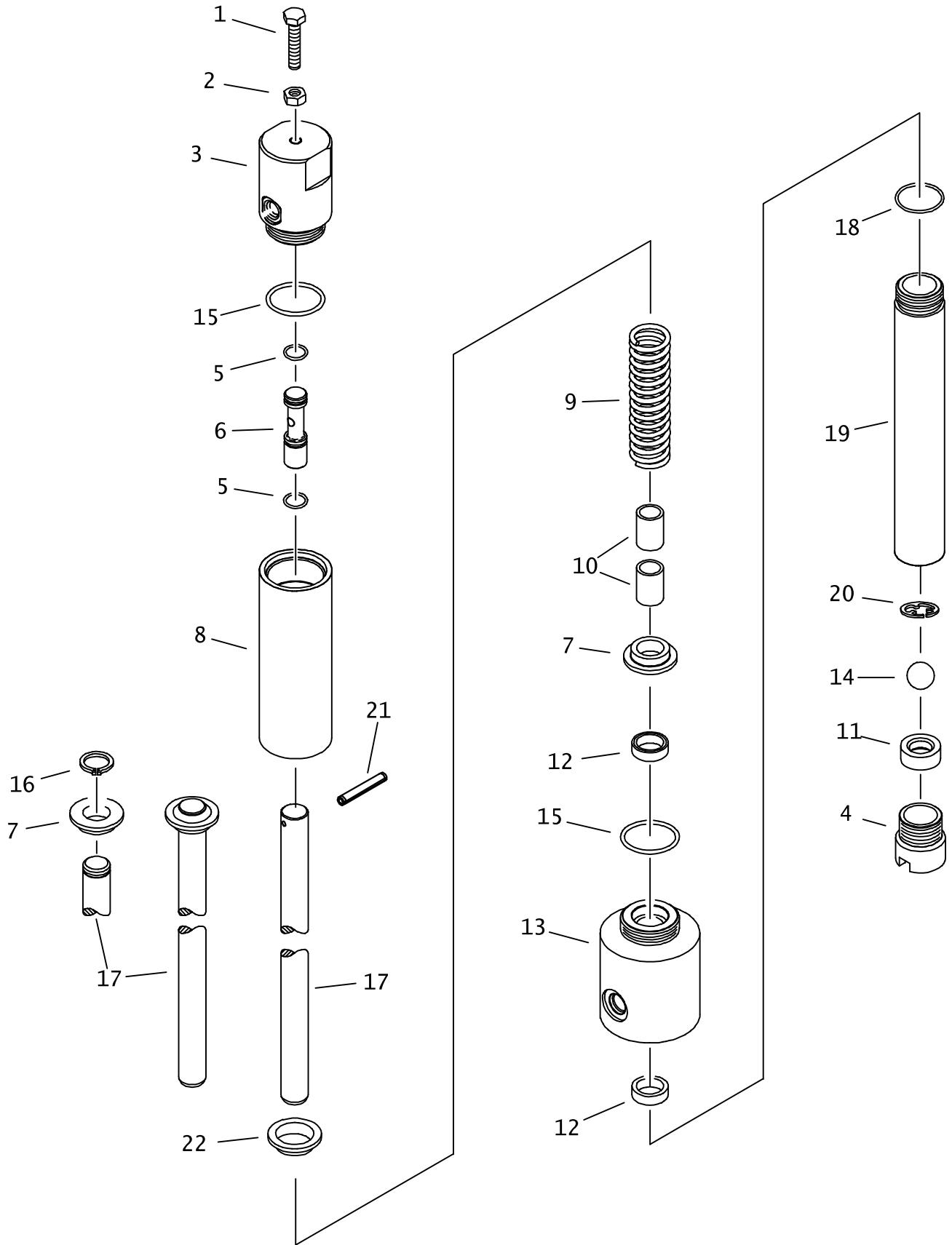

GREASE PUMP

REF NO.	PART NUMBER	QTY	DESCRIPTION	REMARKS
	350-398		GREASE PUMP PARTS	INCL REF NO'S 1-20
1.	107-492	1	SCREW (M8-1.25 X 35MM, ALL THD)	
2.	106-078	1	NUT (M8-1.25)	
3.	350-686	1	CYLINDER CAP	
4.	350-692	1	INLET TUBE	
5.	157-049	2	O-RING (113 D70)	
6.	350-421	1	ADJUSTING SPOOL	
7.	350-671	1	ROD GUIDE	SEE FOOTNOTE 2
8.	350-682	1	BARREL	
9.	117-228	1	COMPRESSION SPRING	
10.	125-424	2	BRONZE BUSHING (.750")	
11.	350-691	1	VALVE SEAT	SEE FOOTNOTE 1
12.	117-227	2	SEAL (POLY PAK)	
13.	350-687	1	PUMP BODY	
14.	125-125	1	DETENT BALL (.750")	
15.	155-702	2	O-RING (920 D90)	
16.	117-226	-	EXTERNAL SNAP RING (.750")	SEE FOOTNOTE 2
	115-545	-	EXTERNAL SNAP RING (.75")	
17.	350-689	-	PLUNGER	SEE FOOTNOTE 2
	308-603	-	PLUNGER	SEE FOOTNOTE 3
	166-280	1	PLUNGER	
18.	155-748	1	O-RING (916 D90)	
19.	350-693	1	PUMP BARREL	
20.	301-0196	1	RETAINER CLIP	SEE FOOTNOTE 4
21.	105-525	1	ROLL PIN (3/16" X 1/4")	SEE FOOTNOTE 3
22.	178-467	1	ROD CAP	SEE FOOTNOTE 3

NOT SHOWN:

FOOTNOTES:

1. INSTALL WITH SMALLER BEVEL TOWARD INSIDE OF PUMP
2. 308-603 PLUNGER IS A DIRECT REPLACEMENT OF 350-689 PLUNGER, 117-226 RETAINER R NG, AND AN ADDITIONAL 350-671 ROD GUIDE.
3. USE 166-280, 178-467 & 105-525 TO SUPERSEDE 308-603
4. RETAINER CLIP 301-0196 SUPERSEDES CLIP 105-653

NOTE:

APPLICATOR

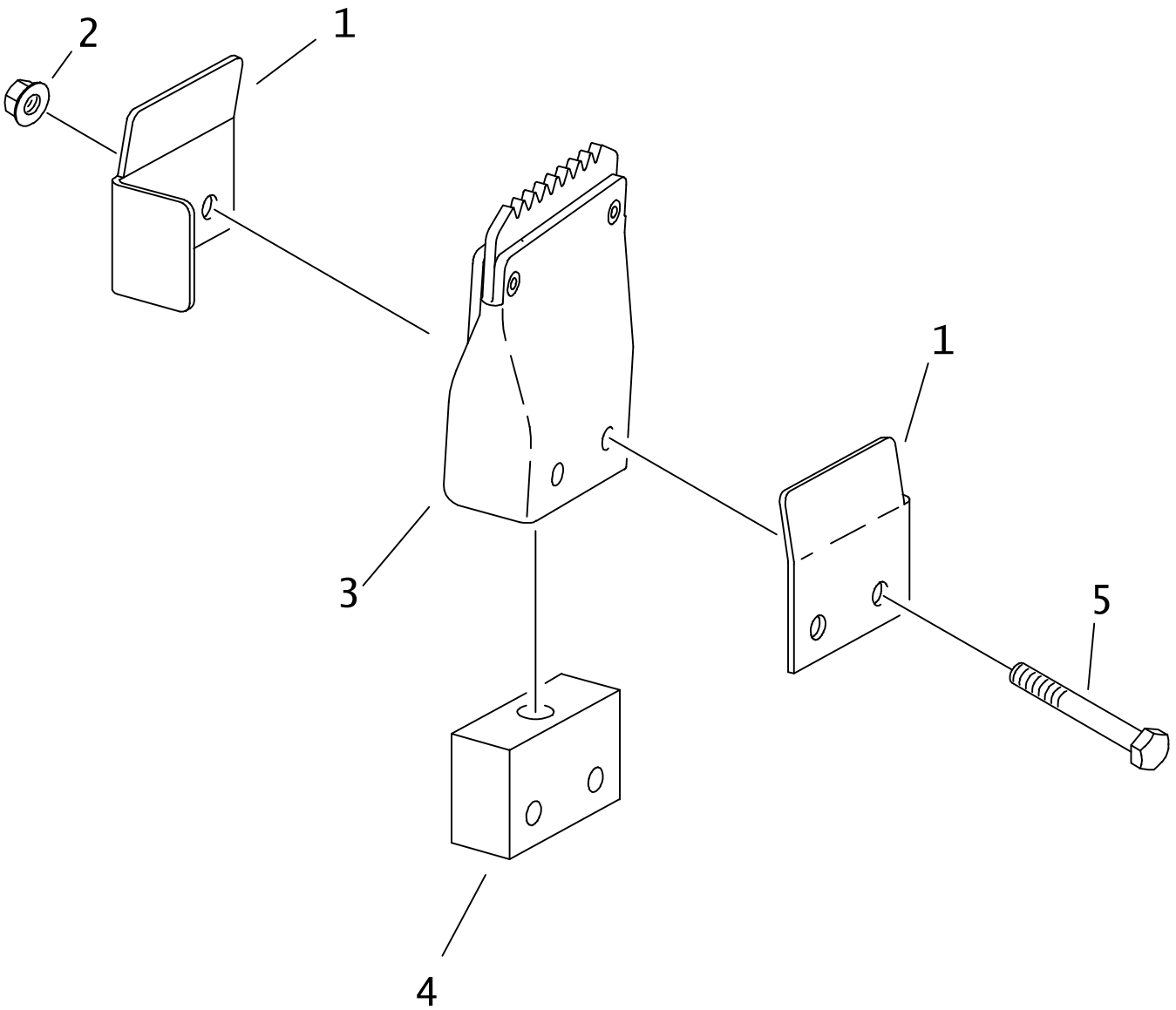

APPLICATOR

REF NO.	PART NUMBER	QTY	DESCRIPTION	REMARKS
1.	305-911	2	BRACKET, APPLICATOR	
2.	106-385	2	FLG LOCKNUT (M6-1.00)	
3.	306-423	1	WIPER PARTS ASS'Y	
	116-937	1	APPLICATOR	
	107-394	4	WASHER (.375", ALUMINUM)	
	107-395	2	RIVET (.156 X .500) SEMI-TUBUL	
4.	305-912	1	BASE, APPLICATOR	
5.	106-093	2	SCREW (M6-1.00 X 45MM)	

NOT SHOWN:

FOOTNOTES:

NOTE:

NOTES:

DRILL FRAME

PIVOT

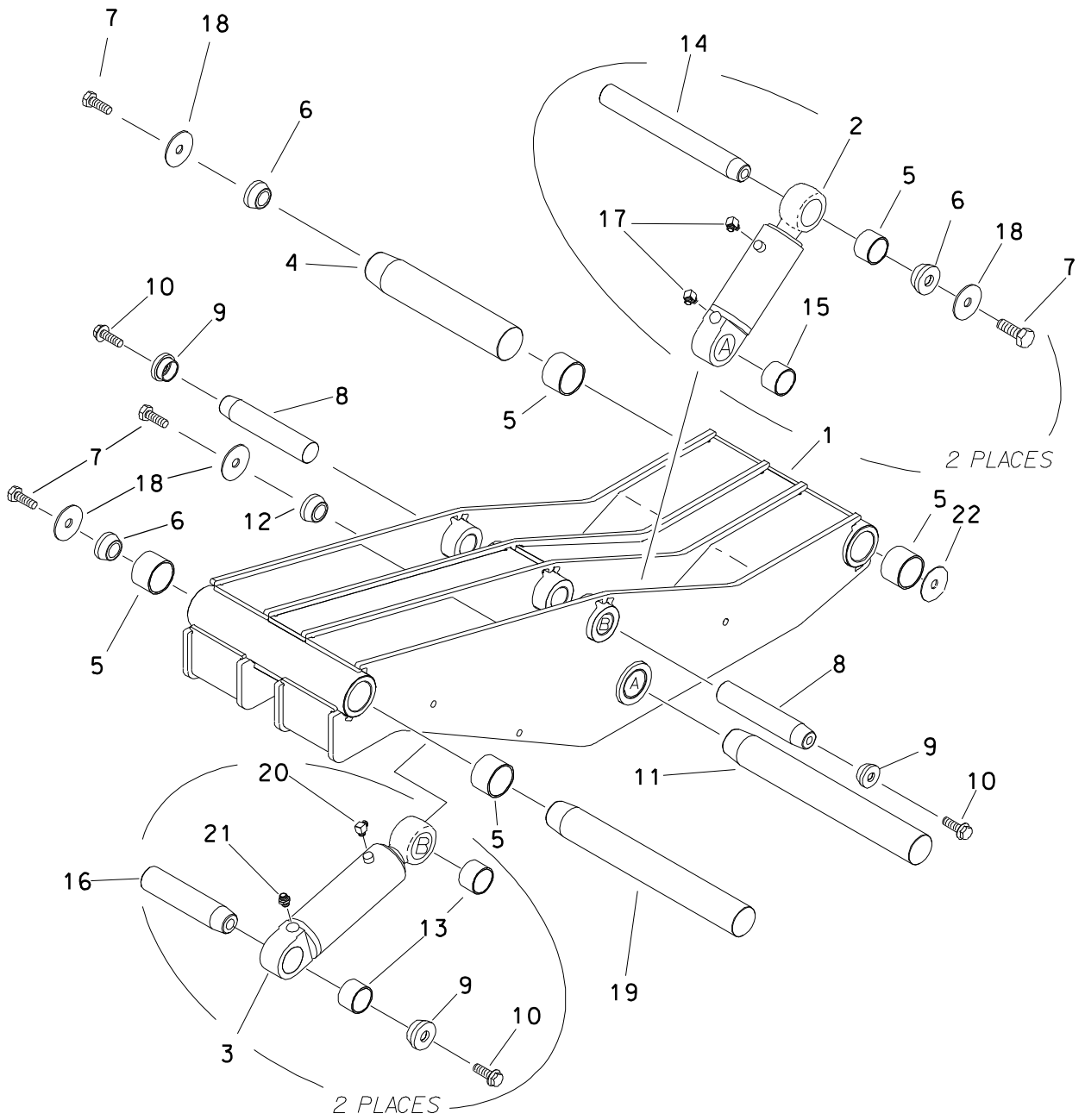

PIVOT

REF NO.	PART NUMBER	QTY	DESCRIPTION	REMARKS
1.	350-724	1	PIVOT	
2.	151-066	2	CYL (4" X 2" X 5")	
3.	151-070	2	CYL (3" X 1.75" X 8")	
4.	179-220	1	TAPERED PIN (50.8mm X 585mm)	
5.	125-754	6	COMPOSITION BUSHING (2")	
6.	184-064	4	TAPERED INSERT (2.00")	
7.	106-798	5	SCREW (M20-2.50 X 55MM, 10.9)	
8.	183-768	2	TAPERED PIN (44.4mm X 205mm)	
9.	181-975	4	TAPERED INSERT (1.750")	
10.	106-470	4	FLG SCREW (M16-2.00 X 40mm)	
11.	179-221	1	TAPERED PIN (57.1mm X 425mm)	
12.	184-031	1	TAPERED INSERT (2.250")	
13.	125-773	4	COMPOSITION BUSHING (1.75")	
14.	179-077	2	TAPERED PIN (50.8mm X 170mm)	
15.	125-781	2	COMPOSITION BUSHING (2.259")	
16.	183-882	2	TAPERED PIN (44.4mm X 228.6mm)	
17.	154-276	4	CONNECTOR (040-08S90)	
18.	106-399	5	WASHER (M20, HARDENED)	
19.	179-248	1	2.0" X 22.04" PIN	
20.	154-226	2	CONNECTOR (040-06S90)	
21.	154-220	2	CONNECTOR (040-06S)	
22.	110-168	4	MACHINERY BUSHING (2.00")	

FOOTNOTES

NOTE
REFER TO O-RING CHART (800-301) IN BACK OF THE BOOK FOR REPLACEMENT OF O-RINGS.

RACK MOUNTING

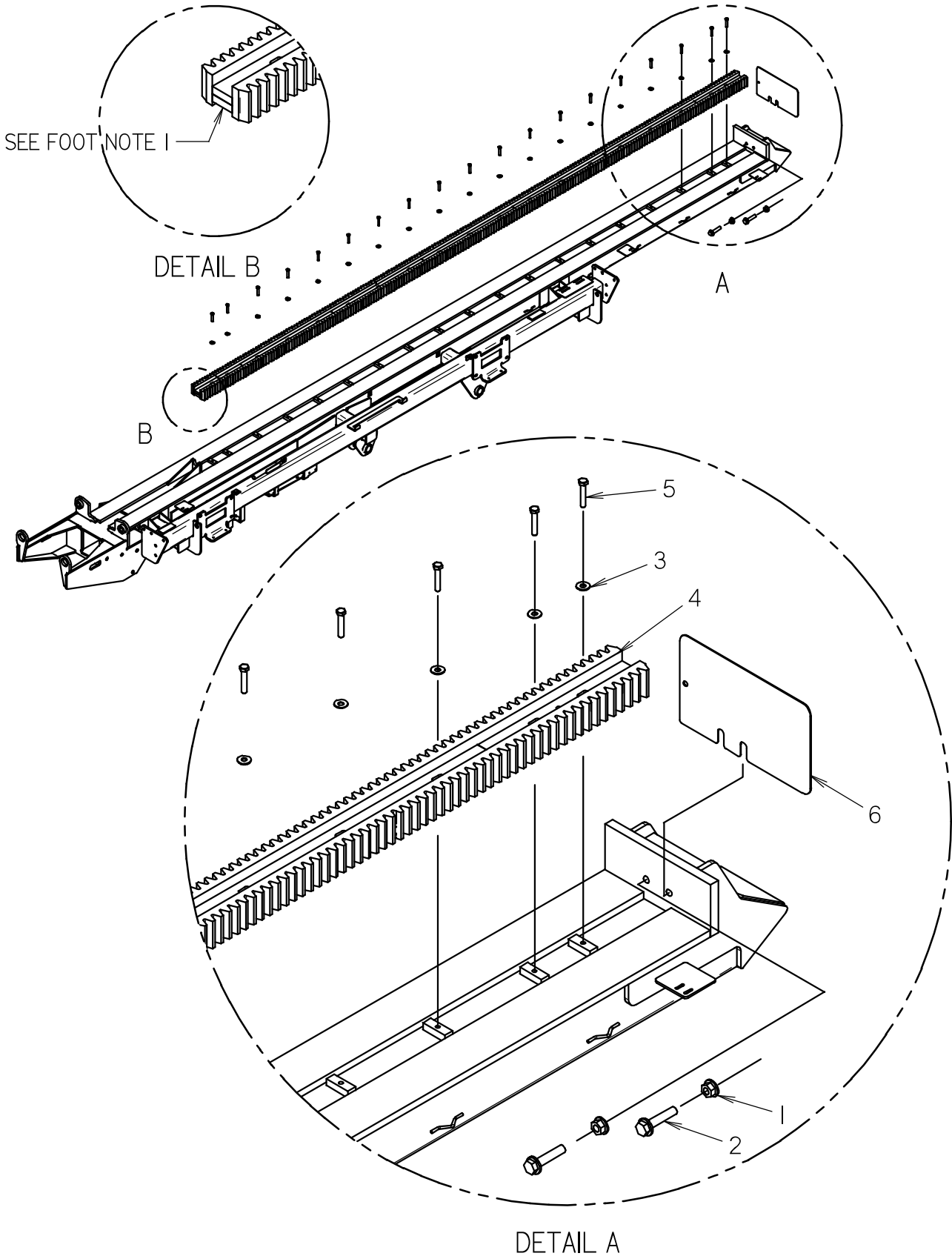

RACK MOUNTING

REF NO.	PART NUMBER	QTY	DESCRIPTION	REMARKS
1	106-356	2	FLG NUT (M20-2.50, 10.9)	
2	106-486	2	FLG SCREW(M20-2.50X 90MM,10.9)	
3	105-059	19	WASHER (7/16")	
4	327-1087	1	RACK ASSEMBLY	SEE FOOTNOTE 1
5	107-507	19	SCREW (M12-1.75 X 65MM)	TORQUE TO 60 FT LB
6	327-1093	1	SHIELD	

NOT SHOWN:

FOOTNOTES:
1. MOUNT END WITH BLOCKS FLUSH TOWARDS FRONT.

NOTE:

THRUST COUPLER AND SHOCK; RACK

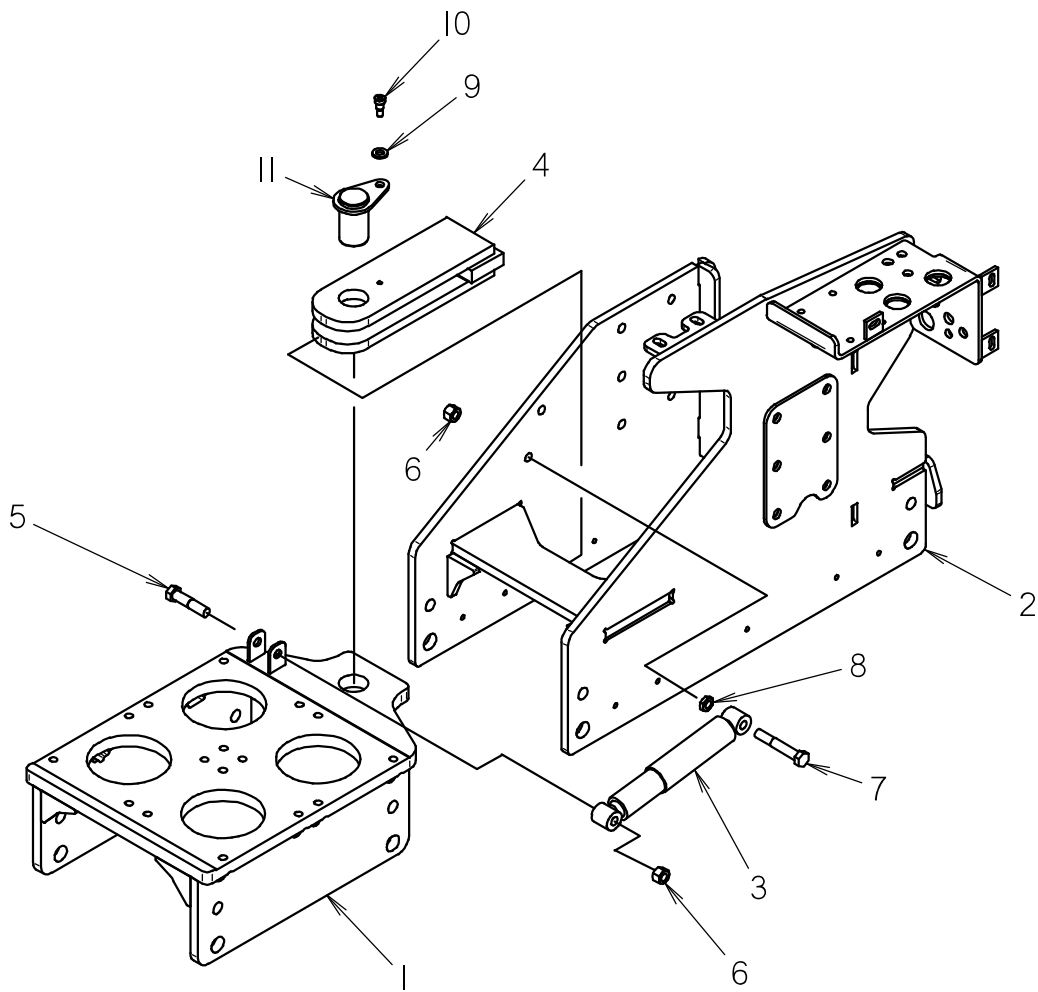

THRUST COUPLER AND SHOCK; RACK

REF NO.	PART NUMBER	QTY	DESCRIPTION	REMARKS
1	327-1039	1	THRUST DRIVE CARRIAGE	
2	327-1043	1	4020 RACK CARRIAGE	
3	110-070	1	SHOCK ABSORBER	
4	327-1054	1	THRUST COUPLER	
5	107-457	1	SCREW (M16-2.0 X 75MM, 10.9)	
6	106-545	2	LOCKNUT (M16-2.0,PRV TRQ,10.9)	
7	107-144	1	SCREW (M16-2.00 X 100MM)	
8	106-775	1	JAM NUT (M16-2.00)	
9	106-397	1	WASHER (M12, HARDENED)	
10	105-748	1	SHLD BLT (1/2" X 1/2", 3/8-NC)	LOCTITE 242
11	327-1094	1	PIN 2.00"	

NOT SHOWN:

FOOTNOTES:

NOTE:

THRUST DRIVE, RACK

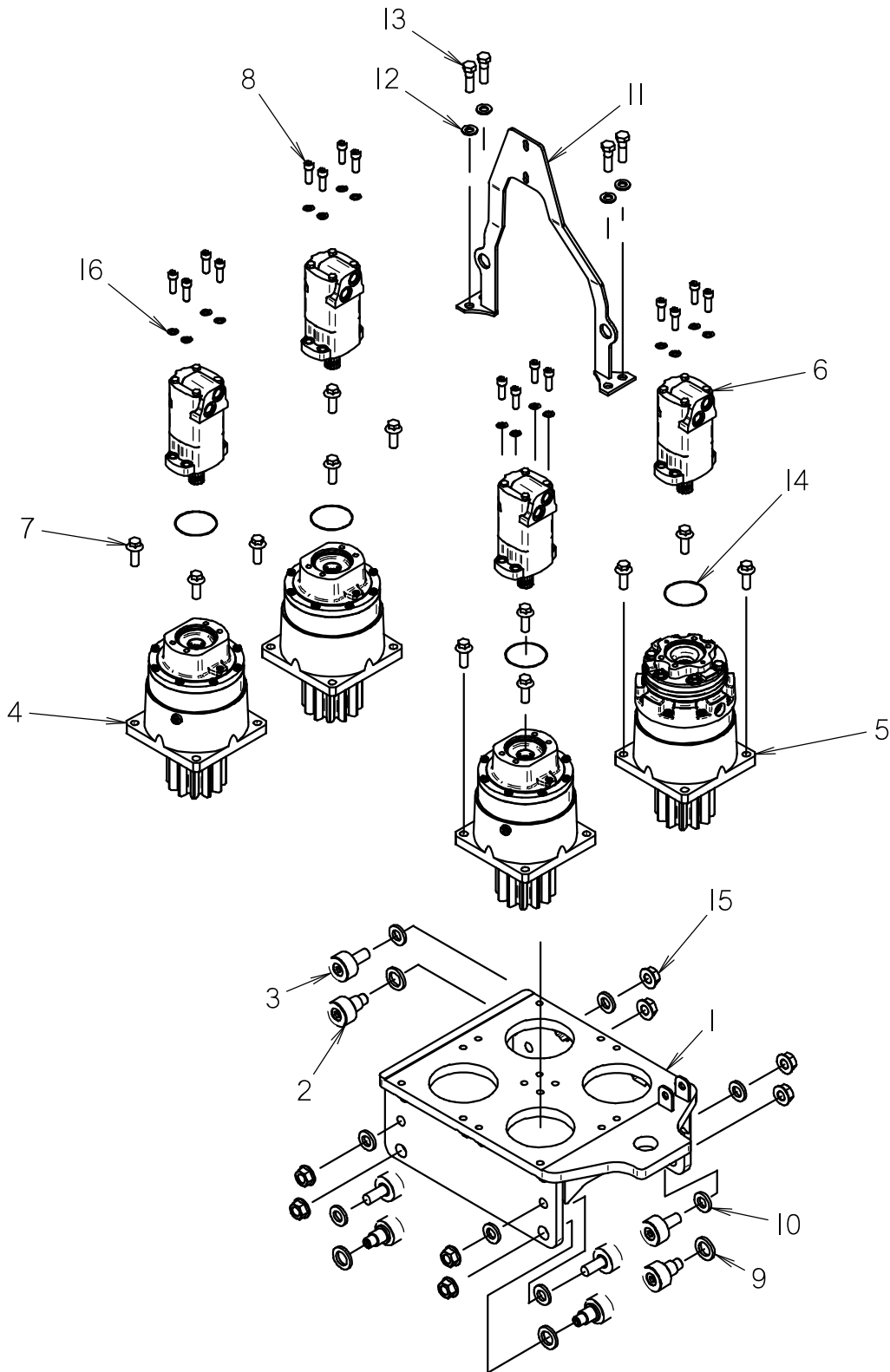

THRUST DRIVE, RACK

REF NO.	PART NUMBER	QTY	DESCRIPTION	REMARKS
1	327-1039	1	THRUST DRIVE CARRIAGE	
2	140-1052	4	ROLLER	SEE FOOTNOTE 1
3	140-1041	4	ROLLER	SEE FOOTNOTE 1
4	160-1030	3	THRUST DRIVE GEARBOX	SEE FOOTNOTE 2
5	160-1074	1	THRUST DRIVE GEARBOX W/BRAKE	SEE FOOTNOTE 2
6	158-270	4	HYDRAULIC MOTOR	
7	107-336	12	FLG SCREW (M16-2.00X45MM,10.9)	USE LOCTITE 242 OR EQUIVALENT. TORQUE TO 250 FT LB
8	106-204	16	BOLT (1/2 - NC X 1.50", SOC)	TORQUE TO 100 FT LB
9	327-1058	4	ROLLER SPACER	
10	105-363	8	WASHER (7/8")	
11	327-1070	1	BRACKET	
12	106-398	4	WASHER (M16, HARDENED)	
13	106-616	4	SCREW (M16-2.00 X 55MM, 10.9)	USE LOCTITE 242 OR EQUIVALENT. TORQUE TO 200 FT LB
14	157-099	4	O-RING (042 D70)	
15	105-362	8	FLG NUT (7/8-NF)	USE LOCTITE 242 OR EQUIVALENT. TORQUE TO 80 FT LB
16	105-070	16	LOCK WASHER (1/2")	

NOT SHOWN:

FOOTNOTES:

1. SET ROLLERS AT.004"--.010" WITH NO PAINT ON RAIL
2. INSTALL AFTER ROLLERS. FILL COMPLETELY WITH APPROXIMATELY 40 OZ SAE 80W90. SEE OPERATORS MANUAL FOR CORRECT FILL LOCATIONS.

NOTE:

THRUST DRIVE GEARBOX

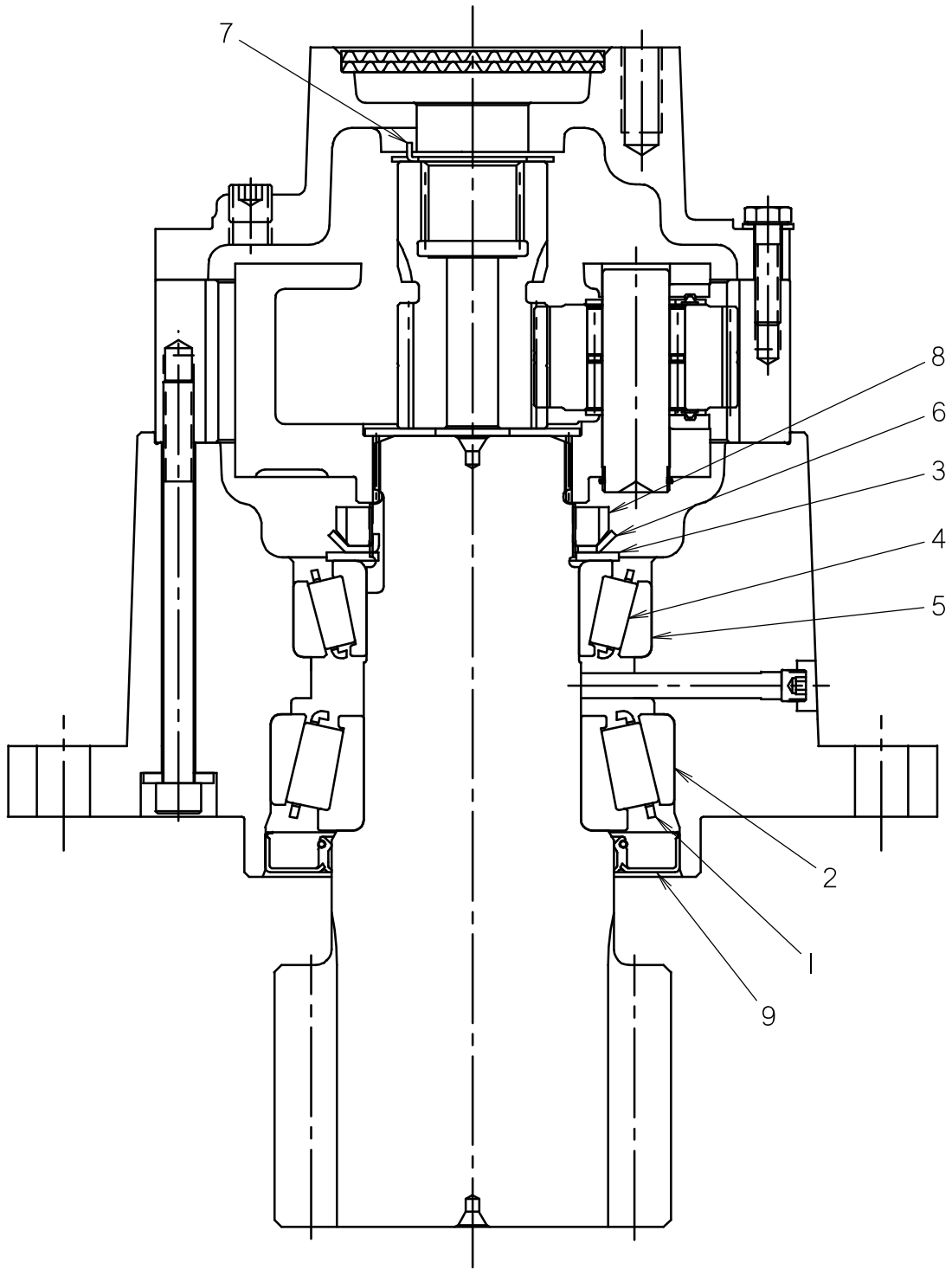

THRUST DRIVE GEARBOX

REF NO.	PART NUMBER	QTY	DESCRIPTION	REMARKS
1.	500-1662	1	BEARING-CONE-6B	
2.	500-1661	1	BEARING-CUP-6B	
3.	500-1666	1	THRUST WASHER-7"	
4.	500-1660	1	BEARING-CONE-7"	
5.	500-1659	1	BEARING-CUP-7"	
6.	500-1657	1	LOCK WASHER-7"	
7.	499-893	1	THRUST WASHER	
8.	500-1663	1	LOCK NUT-7"	
9.	157-521	1	OIL SEAL	SEE FOOTNOTE 1
	500-1674	1	OIL SEAL	SEE FOOTNOTE 2

NOT SHOWN:

500-1696	1	ASSY BRAKE-A2 SERIES; AUSCO
500-1690	1	SPINDLE/SHAFT DRIVE TOOL
500-1690	1	BEARING CONE DRIVER
500-1692	1	BEARINGLOCKNUT TOOL
500-2009	1	O-RING/GASKET KIT
500-2115	1	DISC KIT-2 ROTOR

FOOTNOTES:

1. USED ON 160-1035
2. USED ON 160-1030 & 160-1074

NOTE:

CARRIAGE; AT

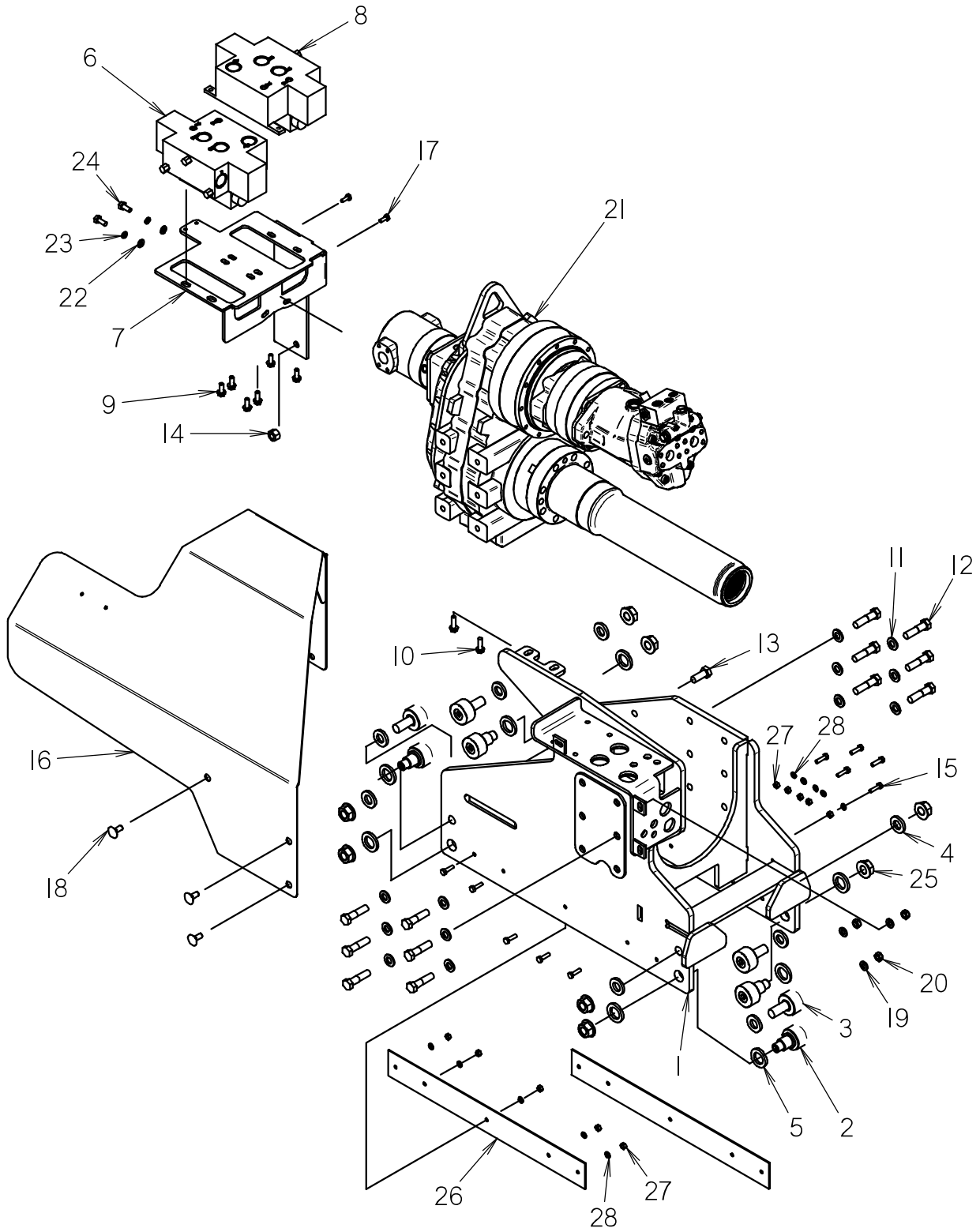

CARRIAGE; AT

REF NO.	PART NUMBER	QTY	DESCRIPTION	REMARKS
1	327-1043	1	4020 RACK CARRIAGE	
2	140-1052	4	ROLLER	SEE FOOTNOTE I
3	140-1041	4	ROLLER	SEE FOOTNOTE I
4	105-363	8	WASHER (7/8")	
5	327-1058	8	ROLLER SPACER	
6	153-773	1	INNER ROTATION VALVE	
7	327-1074	1	VALVE MOUNT BRACKET	
8	150-2712	1	THRUST VALVE	
9	105-826	6	FLG LK BOLT (3/8-NC X 1")	LOCTITE 242
10	105-827	2	FLG LK BOLT (3/8-NC X 1-1/4")	LOCTITE 242
11	106-398	12	WASHER (M16, HARDENED)	
12	106-666	12	SCREW (M16-2.00 X 65MM, 10.9)	LOCTITE 277, TORQUE TO 225 ftlb
13	105-998	1	SCREW (M16-2.00 X 40MM)	
14	106-545	1	LOCKNUT (M16-2.0,PRV TRQ,10.9)	
15	106-327	10	SCREW (M8-1.25 X 30MM)	
16	327-1077	1	CARRIAGE COVER	
17	106-083	2	SCREW (M8-1.25 X 20MM)	LOCTITE 242
18	107-683	3	CARRIAGE BOLT (M12-1.75 X 30MM)	
19	106-391	3	WASHER (M12)	
20	106-685	3	LOCKNUT (M12-1.75,PRV TRQ,10.9)	
21	166-396	1	AT4020 ROTATION DRIVE	
22	106-390	2	WASHER (M10)	
23	106-090	2	LOCK WASHER (M10)	
24	105-245	2	SCREW (M10-1.50 X 25MM)	
25	105-362	8	FLG NUT (7/8-NF)	LOCTITE 242, TORQUE TO 80 ftlb
26	327-1091	2	WEAR BAR	INSTALL INSIDE CARRIAGE AFTER SET ON DRILL FRAME
27	106-561	10	LOCKNUT (M8-1.25,PRV TRQ,10.9)	
28	106-389	10	WASHER (M8)	

NOT SHOWN:

FOOTNOTES:

I. SET ROLLERS AT .004"-.010" WITH NO PAINT OF RAIL.

NOTE:

CARRIAGE, JT

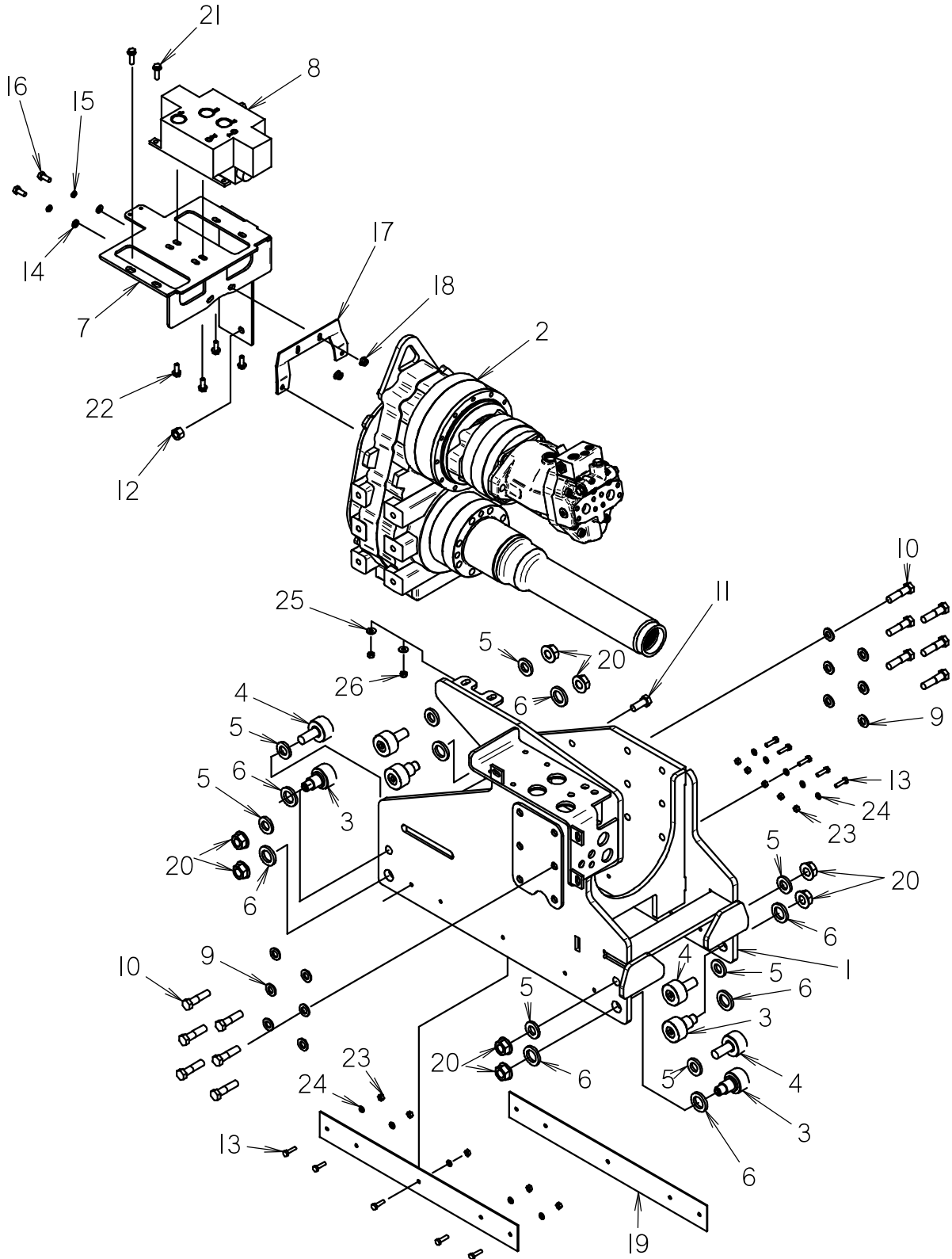

CARRIAGE, JT

REF NO.	PART NUMBER	QTY	DESCRIPTION	REMARKS
1	327-1043	1	4020 RACK CARRIAGE	
2	166-482	1	JT4020 ROTATION DRIVE	
3	140-1052	4	ROLLER	SEE FOOTNOTE 1
4	140-1041	4	ROLLER	SEE FOOTNOTE 1
5	105-363	8	WASHER (7/8")	
6	327-1058	8	ROLLER SPACER	
7	327-1074	1	VALVE MOUNT BRACKET	
8	150-2712	1	THRUST VALVE	
9	106-398	12	WASHER (M16, HARDENED)	
10	106-666	12	SCREW (M16-2.00 X 65MM, 10.9)	LOCTITE 277, TORQUE TO 225 ftlb
11	105-998	1	SCREW (M16-2.00 X 40MM)	
12	106-545	1	LOCKNUT (M16-2.0,PRV TRQ,10.9)	
13	106-327	10	SCREW (M8-1.25 X 30MM)	
14	106-390	2	WASHER (M10)	
15	106-090	2	LOCK WASHER (M10)	
16	105-245	2	SCREW (M10-1.50 X 25MM)	LOCTITE 242
17	327-1083	1	BRACKET	
18	106-387	2	FLG LOCKNUT (M10-1.50)	
19	327-1091	2	WEAR BAR	INSTALL ON INSIDE OF CARRIAGE AFTER SET ON DRILL FRAME
20	105-362	8	FLG NUT (7/8-NF)	LOCTITE 242, TORQUE TO 80 ftlb
21	105-827	2	FLG LK BOLT (3/8-NC X 1-1/4")	
22	105-826	4	FLG LK BOLT (3/8-NC X 1")	LOCTITE 242
23	106-561	10	LOCKNUT (M8-1.25,PRV TRQ,10.9)	
24	106-389	10	WASHER (M8)	
25	105-117	2	WASHER (5/16")	
26	105-047	2	LOCKNUT (3/8-NC)	

NOT SHOWN:

FOOTNOTES:

1. SET ROLLERS AT .004"-.010" CLEARANCE WITH NO PAINT ON THE RAIL.

NOTE:

USE (A1) VERSION PAGE FOR CARRIAGE COVER AND MOUNTING HARDWARE

ROTATION GEARBOX

JT42M1 & JT42T2 ONLY

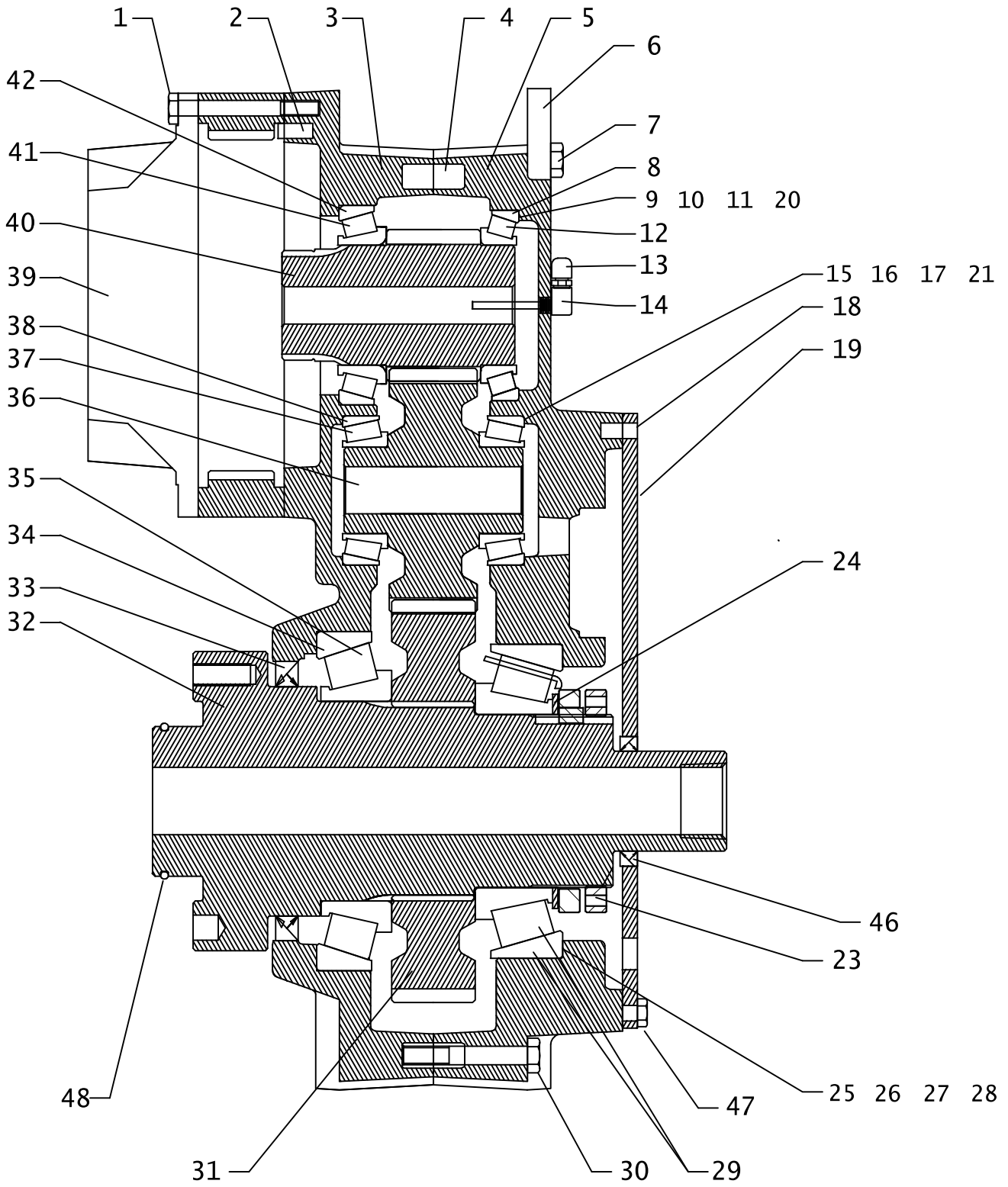

ROTATION GEARBOX
JT42M1 & JT42T2 ONLY

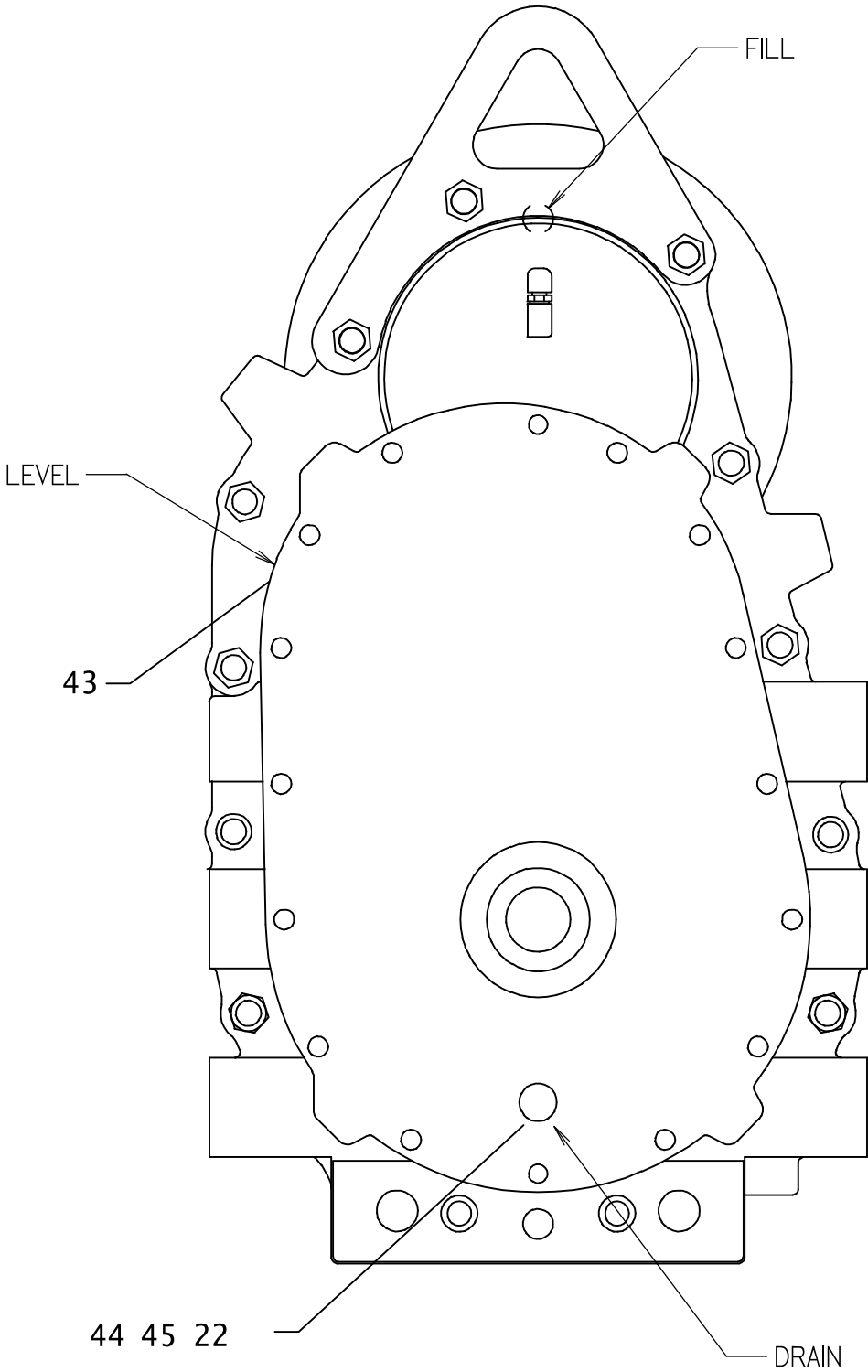

ROTATION GEARBOX JT42M1 & JT42T2 ONLY

REF NO.	PART NUMBER	QTY	DESCRIPTION	REMARKS
	166-487	-	{JT} REBUILT ROTATION GEARBOX	
	166-489	-	{JT} ROTATION DRIVE GEARBOX	
1.	105-179	12	BOLT (3/8-NC X 3-1/2")	INCLUDES REF. #'S 1 - 49. TORQUE TO 40 FT LBS.
2.	105-534	3	DOWEL PIN (.375" X .875")	
3.	314-590	1	COVER CASTING (MACHINED)	
4.	500-818	2	DOWEL PIN (16MM X 40MM)	
5.	314-356	1	COVER CASTING (MACHINED)	
6.	313-947	-	LIFT BRACKET	
7.	106-336	-	SCREW (M12-1.75 X 90MM)	
8.	125-359	1	TAPERED RACE (4.781")	
9.	165-868	3	SHIM (.076MM)	
10.	165-869	3	SHIM (.051MM)	
11.	165-870	3	SHIM (.178MM)	
12.	125-360	1	TAPERED BEARING (3.000")	
13.	159-003	1	AIR VENT (02N)	
14.	514-123	1	PICKUP TUBE (02N-02NF90-2")	
15.	165-842	3	SHIM (.051MM)	
16.	165-843	3	SHIM (.076MM)	
17.	165-844	3	SHIM (.178MM)	
18.	106-866	2	DOWEL PIN (M10 X 30MM)	
19.	318-398	1	COVER	
20.	107-578	2	SHIM (.020")	
21.	107-577	2	SHIM (.020")	
22.	115-112	1	PLUG (08N, SQ)	
23.	<u>107-706</u>	1	NUT, SPANNER	
	190-1386	1	GEARBOX NUT	
	255-1006	-	MOLLY PASTE (SINGLE APPLICATION)	
24.	105-1313	1	HARDEND WASHER	
25.	165-810	3	SHIM (.002")	
26.	165-811	3	SHIM (.003")	
27.	165-812	3	SHIM (.007")	
28.	179-310	2	SHIM .020"	SEE FOOTNOTE 3
29.	125-1009	1	TAPERED BRNG/RACE (110MM)	
30.	106-117	10	SCREW (M12-1.75 X 80MM)	
31.	168-036	1	OUTPUT GEAR	
32.	166-389	1	SHAFT	
33.	153-615	1	INTERNAL SEAL (5.750" ID)	
34.	125-500	1	BEARING CUP	
35.	125-525	1	CONE	

NOT SHOWN:

FOOTNOTES:

NOTE:

ROTATION GEARBOX JT42M1 & JT42T2 ONLY

REF NO.	PART NUMBER	QTY	DESCRIPTION	REMARKS
36.	168-035	1	IDLER GEAR	
37.	126-170	2	TAPERED BEARING (2.250")	
38.	126-171	2	TAPERED RACE (3.740")	
39.	166-152	1	ROTATION GEARBOX PLANETARY	SEE FOOTNOTE 1
40.	168-034	1	INPUT PINION	
41.	125-308	1	TAPERED BEARING (3.000")	
42.	125-309	1	TAPERED RACE (5.000")	
43.	115-025	1	PLUG (08N, SQ FM, MAG)	
44.	115-162	1	NIPPLE (08N-4")	
45.	115-155	1	COLLAR (08NF)	
46.	153-638	1	INTERNAL SEAL	
47.	106-755	14	SCREW (M10-1.50 X 30MM, S0C)	
48.	157-285	1	O-RING (238 D75 VITON)	

NOT SHOWN:

FOOTNOTES:

1. APPLY LOCTITE SUPERFLEX RED HIGH TEMP RTV OR EQUIVALENT - 3/16 DIA. MIN. BEAD.
2. THIS ITEM WILL COME IN GEARBOX. REMOVE AND INSTALL ITEMS 44,45,& 49.
3. 126-172 SUPERSEDED BY 125-1009. TIMKEN® 32222M WILL NOT WORK IN THIS APPLICATION.

NOTE:

ROTATION GEARBOX
JT4020 ALL TERRAIN ONLY
BEGINS WITH S/N: CMWA40T3K70000018

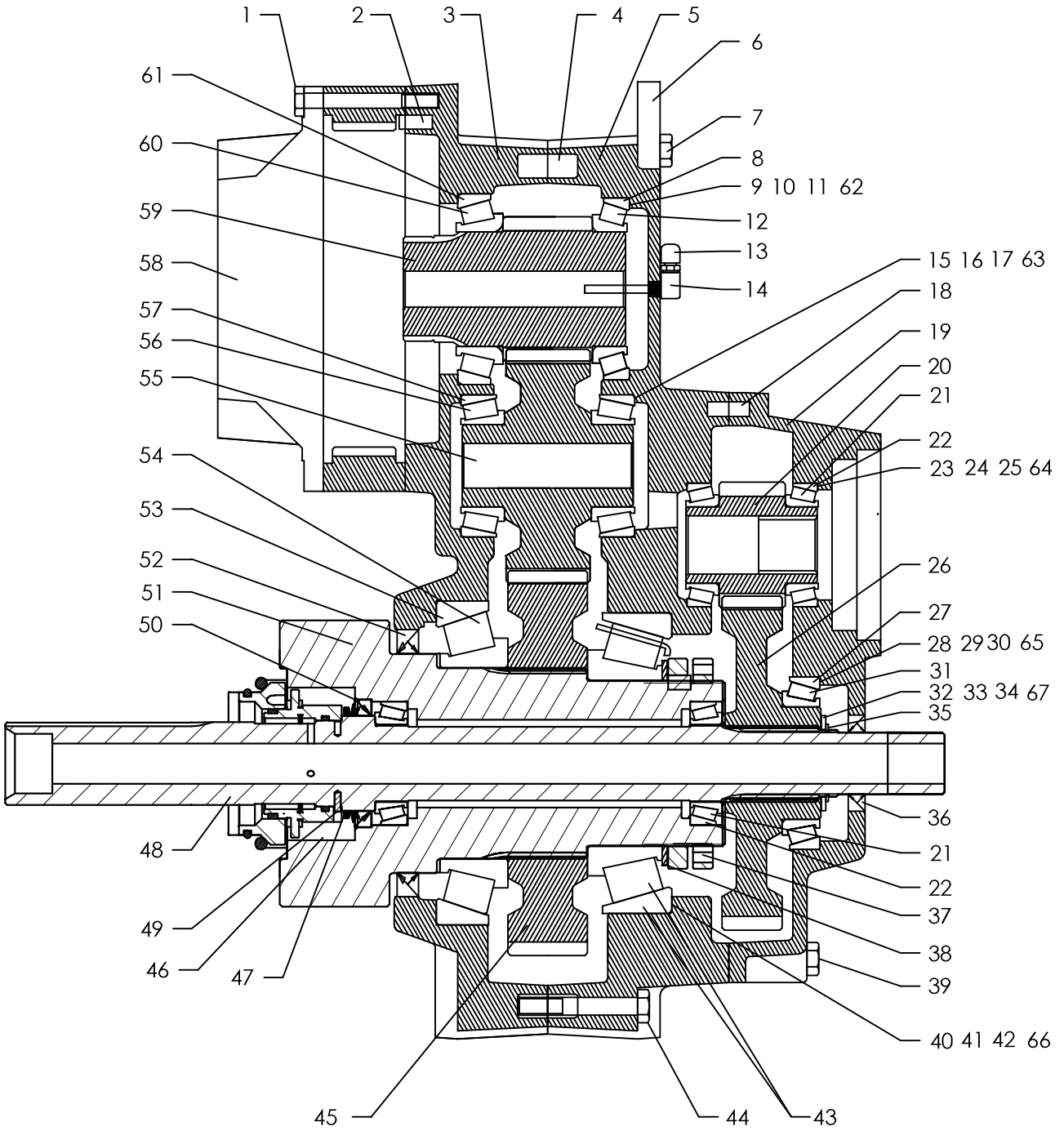

ROTATION GEARBOX
JT4020 ALL TERRAIN ONLY
BEGINS WITH S/N: CMWA40T3K70000018

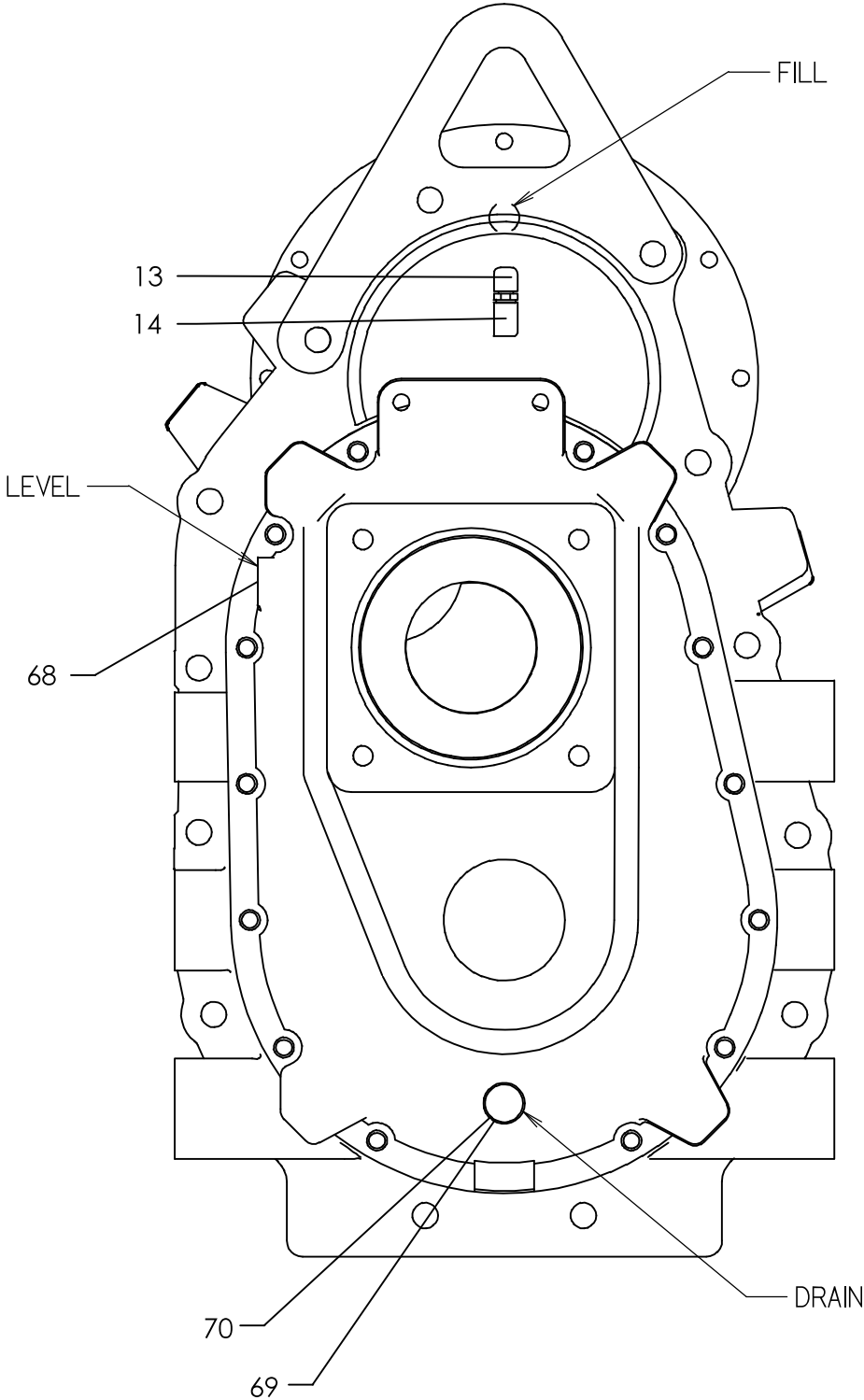

ROTATION GEARBOX
JT4020 ALL TERRAIN ONLY
BEGINS WITH S/N: CMWA40T3K70000018

REF NO.	PART NUMBER	QTY	DESCRIPTION	REMARKS
	166-468	-	{AT} REBUILT GEARBOX	
	166-488	-	{AT} ROTATION DRIVE GEARBOX	NEW GEARBX, INCL REF. #S 1-45,47,48,50-71.
1.	105-179	12	BOLT (3/8-NC X 3-1/2")	TORQUE TO 40 FT LBS. (54 N - M)
2.	105-534	3	DOWEL PIN (.375" X .875")	
3.	314-590	1	COVER CASTING (MACHINED)	
4.	500-818	2	DOWEL PIN (16MM X 40MM)	
5.	314-356	1	COVER CASTING (MACHINED)	
6.	313-947	-	LIFT BRACKET	
7.	106-336	-	SCREW (M12-1.75 X 90MM)	
8.	125-359	1	TAPERED RACE (4.781")	
9.	165-868	3	SHIM (.076MM)	
10.	165-869	3	SHIM (.051MM)	
11.	165-870	3	SHIM (.178MM)	
12.	125-360	1	TAPERED BEARING (3.000")	
13.	159-003	1	AIR VENT (02N)	
14.	514-123	1	PICKUP TUBE (02N-02NF90-2")	
15.	165-842	3	SHIM (.051MM)	
16.	165-843	3	SHIM (.076MM)	
17.	165-844	3	SHIM (.178MM)	
18.	106-866	2	DOWEL PIN (M10 X 30MM)	
19.	314-355	1	MOTOR COVER	
20.	166-402	1	INPUT PINION	
21.	126-100	4	TAPERED BEARING (2")	
22.	126-099	4	TAPERED RACE (3.25")	
23.	165-800	2	SHIM (.002")	
24.	165-801	2	SHIM (.003")	
25.	165-802	2	SHIM (.007")	
26.	166-403	1	GEAR	
27.	126-012	1	TAPERED RACE (4.527")	
28.	117-535	2	SHIM	
29.	117-536	2	SHIM	
30.	117-537	2	SHIM	
31.	126-013	1	TAPERED BEARING (2.952")	
32.	107-705	1	BEARING RACE (THRUST)	
33.	126-127	1	THRUST WASHER RACE (1.750")	
34.	117-534	1	SHIM	
35.	115-456	1	EXTERNAL SNAP RING (1.750")	

NOT SHOWN:

FOOTNOTES:

NOTE:

ROTATION GEARBOX
JT4020 ALL TERRAIN ONLY
BEGINS WITH S/N: CMWA40T3K70000018

REF NO.	PART NUMBER	QTY	DESCRIPTION	REMARKS
36.	153-616	1	INTERNAL SEAL (2.535")	
37.	107-706	1	NUT, SPANNER	OBSOLETE
	190-1386	1	GEARBOX NUT	
	255-1006	-	MOLLY PASTE (SINGLE APPLICATION)	
38.	105-1313	1	HARDENED WASHER	
39.	106-755	14	SCREW (M10-1.50 X 30MM, SOC)	
40.	165-810	3	SHIM (.002")	
41.	165-811	3	SHIM (.003")	
42.	165-812	3	SHIM (.007")	
43.	125-1009	1	TAPERED BRNG/RACE (110MM)	SEE FOOTNOTE 2
44.	106-117	10	SCREW (M12-1.75 X 80MM)	
45.	168-036	1	OUTPUT GEAR	
46.	190-1163	1	SEAL KIT	INCLUDES REF. 49
47.	153-614	1	SEAL, V-RING	
48.	166-491	1	SHAFT	
49.	105-1539	1	PIN, GROOVED (5/32" X 1/2")	
50.	155-801	1	INTERNAL SEAL (2.500")	
51.	166-492	1	SHAFT	
52.	153-615	1	INTERNAL SEAL (5.750" ID)	
53.	125-500	1	BEARING CUP	
54.	125-525	1	CONE	
55.	168-035	1	IDLER GEAR	
56.	126-170	2	TAPERED BEARING (2.250")	
57.	126-171	2	TAPERED RACE (3.740")	
58.	166-152	1	ROTATION GEARBOX PLANETARY	SEE FOOTNOTE 1
59.	168-034	1	INPUT PINION	
60.	125-308	1	TAPERED BEARING (3.000")	
61.	125-309	1	TAPERED RACE (5.000")	
62.	107-578	2	SHIM (.020")	
63.	107-577	2	SHIM (.020")	
64.	107-575	2	SHIM (.020")	
65.	179-309	2	SHIM .020"	
66.	179-310	2	SHIM .020"	
67.	110-054	1	MACHINE BUSHING (1-3/4", 14GA)	
68.	115-025	1	PLUG (08N, SQ FM, MAG)	
69.	115-161	1	NIPPLE (08N, 3-1/2")	
70.	514-106	-	CAP (08NF)	

NOT SHOWN:

FOOTNOTES:

1. APPLY LOCTITE SUPERFLEX RED HIGH TEMP RTV OR EQUIVALENT - 3/16 DIA. MIN. BEAD.
2. 126-172 SUPERSEDED BY 125-1009. TIMKEN® 32222M WILL NOT WORK IN THIS APPLICATION.

NOTE:

SPINDLE DRIVE

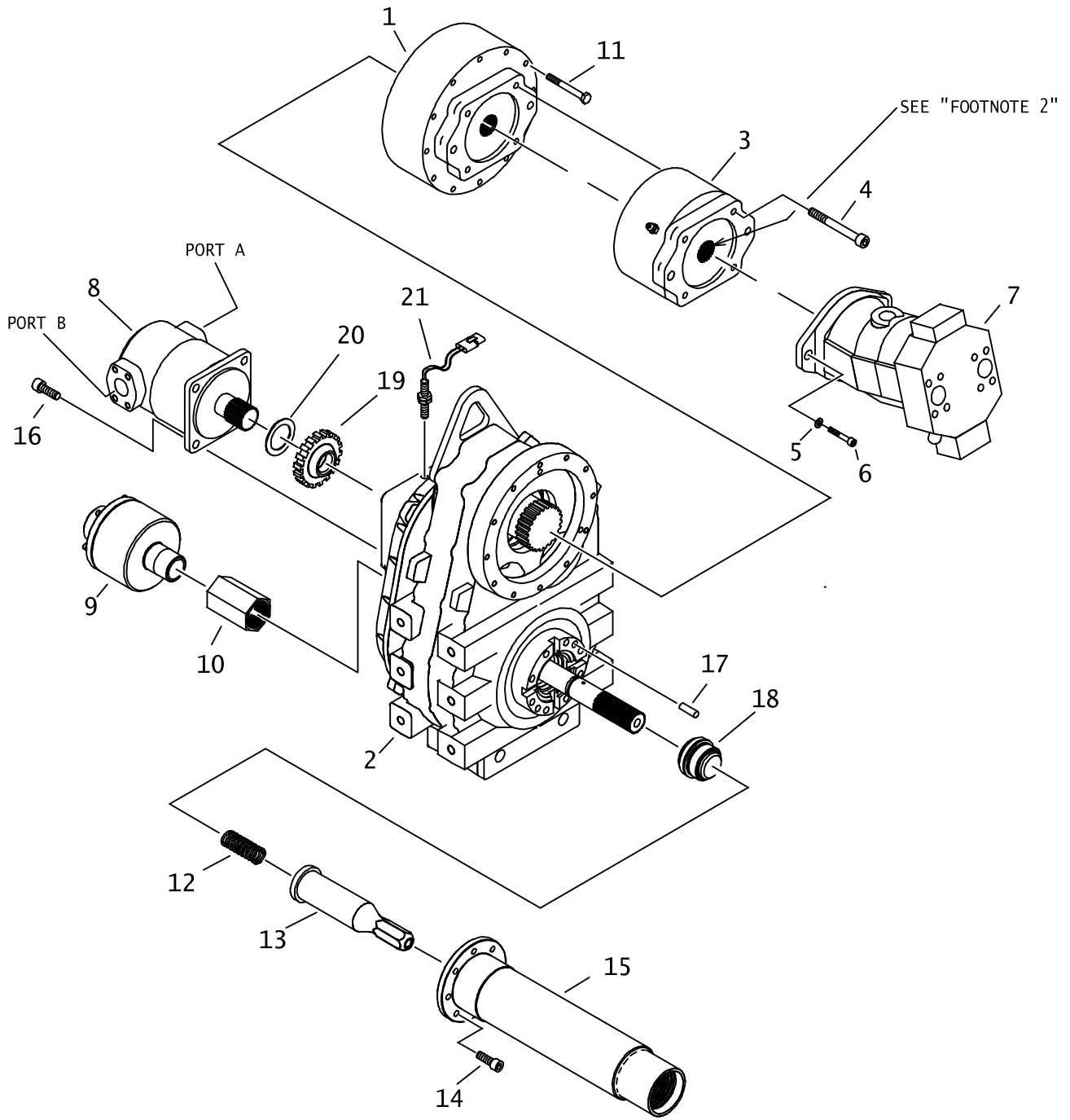

SPINDLE DRIVE

REF NO.	PART NUMBER	QTY	DESCRIPTION	REMARKS
	166-396	-	{AT} ROTATION DRIVE	AT ONLY, INCLUDES REF. #'S 1-8, & 11-21
	166-482	-	{JT} ROTATION DRIVE	JT ONLY, INCLUDES REF. #'S 1-7,11,14,15, & 17.
1.	166-152	-	ROTATION GEARBOX PLANETARY	
2.	166-488	-	{AT} ROTATION DRIVE GEARBOX	
	166-489	-	{JT} ROTATION DRIVE GEARBOX	
3.	160-1099	1	MODULAR BRAKE	APPLY ANTISIEZE AS INDICATED IN FOOTNOTE 2
	163-212	-	BLEEDER SCREW, DISC BRAKE	
	500-1283	-	OIL SEAL	
	191-169	-	STACK SERVICE KIT	
	191-167	-	GASKET KIT	
	191-168	-	BEARING KIT	
	191-166	-	O-RING KIT	
4.	107-495	4	BLT (1/2-NC X 4.50", SOC GD 8)	USE 242 LOCTITE; TORQUE TO 90 FT LBS
5.	106-398	2	WASHER (M16, HARDENED)	
6.	105-997	2	BOLT (5/8-NC X 1-3/4", SOC)	USE 242 LOCTITE; TORQUE TO 175 FT LBS
7.	158-059	1	HYD MOTOR	AT ONLY
	153-244	-	HYD MOTOR	JT ONLY
	214-886	-	SOLENOID COIL	
	502-172	-	HALL SPEED SENSOR	AT ONLY
8.	153-612	1	HYDRAULIC MOTOR	USE RED SILICON, AT ONLY
	191-263	AR	SEAL REPAIR KIT	
9.	153-208	1	WATER SWIVEL (24N-24NF)	SEE FOOTNOTE 5
10.	153-684	1	SPEC BUSHING (-26-24NF)	USE 567 LOCTITE, AT ONLY
11.	105-179	-	BOLT (3/8-NC X 3-1/2")	TORQUE TO 40 FT LBS
12.	117-541	1	SPRING	AT ONLY
13.	316-841	1	HEX	AT ONLY
14.	106-244	8	SCREW (M16-2.00 X 60MM, SOC)	USE 242 LOCTITE; TORQUE TO 225 FT LBS
15.	400-651	1	SAVER SUB	AT PIPE: SEE FOOTNOTE 3
	400-1135	1	SAVER SUB 3.25-4F SS	
	401-265	1	SAVER SUB ASSEMBLY SS 3.25-4F	SEE FOOTNOTE 4
	400-1133	1	SAVER SUB SS 3.25-4F	
	400-957	-	SAVER SUB ASSEMBLY 2.59-4F DS	JT PIPE
	400-1134	1	SAVER SUB 2.59-4F DS	
16.	105-282	4	BOLT (1/2-NC X 1-1/4", SOC)	USE 242 LOCTITE; TORQUE TO 90 FT LBS, AT ONLY
17.	500-818	2	DOWEL PIN (16MM X 40MM)	
18.	191-278	-	SEAL KIT	AT ONLY: SEE FOOTNOTE 3
	190-1163	-	SEAL KIT	SEE FOOTNOTE 4
19.	166-432	1	SPEED SENSOR RING	AT ONLY
20.	110-220	AR	MACH BUSHING (1-1/2", 14GA)	AT ONLY
21.	215-1472	1	PROXIMITY SWITCH 12MM WP	AT ONLY & REFER TO F/N 1 & F/N 6

NOT SHOWN:

FOOTNOTES:

1. INSTALL PROXIMITY SWITCH (REF. 21) TWO TURNS OUT FROM CONTACT WITH SPEED SENSOR RING (REF. 20).
2. APPLY ANTISIEZE TO INTERIOR OF SHAFT COUPLER ON THE BRAKE SECTION (REF. 4) WHERE THE ROTATION MOTOR (REF. 8) MOUNTS BEFORE ASSEMBLY.
3. ENDS WITH S/N: CMWA40T3P70000017
4. BEGINS WITH S/N: CMWA40T3K70000018
5. INSTALL USING NICKLE THREAD SEALING TAPE (117-555) ON MALE THREADS.
6. PROXIMITY SWITCH 215-1472 SUPERCEDES PROXIMITY SWITCH 214-913.

NOTE:

HOSE TRACK

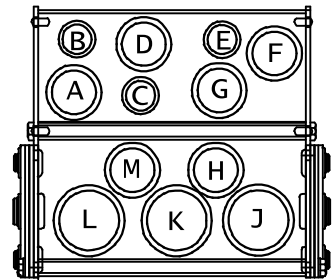
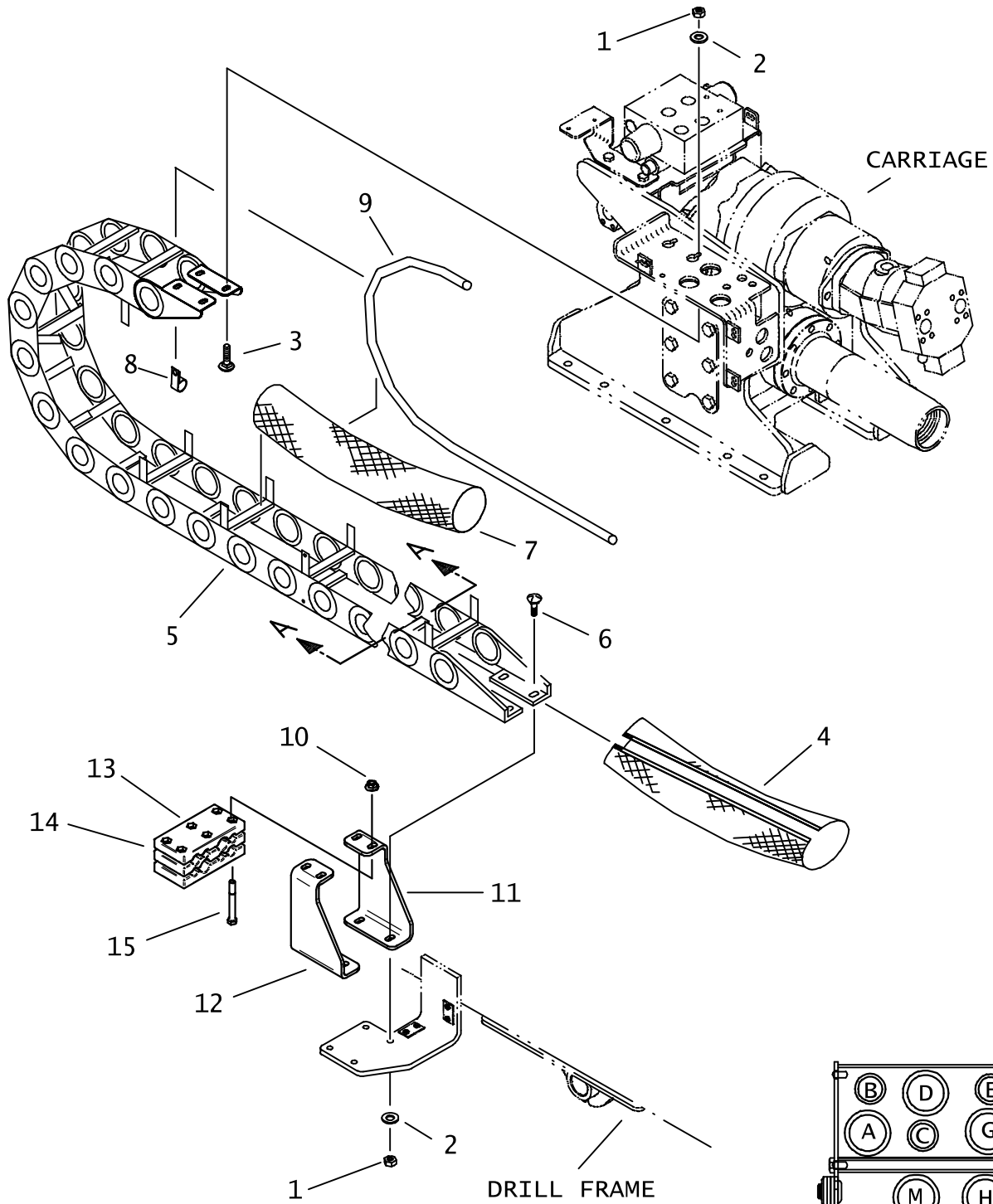

VIEW A-A
SEE NOT SHOWN

HOSE TRACK

REF NO.	PART NUMBER	QTY	DESCRIPTION	REMARKS
1.	105-047	8	LOCKNUT (3/8-NC)	
2.	105-117	6	WASHER (5/16")	
3.	105-600	4	CARRIAGE BOLT (3/8-NC X 1")	
4.	150-1787	-	HOSE BAG FOR 150-1750	4020 WITH RACK AND PINION ONLY
	117-919	-	HOSE BAG W/ELECT HARN PCK	USED ON I17-881 ONLY.
	117-991	-	HOSE BAG	
5.	150-1750	1	HOSE TRACK 4020 R&P	4020 WITH RACK AND PINION ONLY
	117-969	1	HOSE CARRIER	INCLUDES REF NO. 4 & 8.
	499-606	-	REPAIR SECTION, 4-LINK	SEE FOOTNOTE 1. FOR I17-969 AND 150-1750.
	499-604	-	BAR KIT	SEE FOOTNOTE 2. FOR I17-969 AND 150-1750.
	499-605	-	HARDWARE KIT	SEE FOOTNOTE 3. FOR I17-969 AND 150-1750.
	499-607	-	EXTENDER KIT	SEE FOOTNOTE 4. FOR I17-969 AND 150-1750.
	499-608	-	EASY OUT BAR KIT	SEE FOOTNOTE 6. FOR I17-969 AND 150-1750.
	499-567	-	MOUNTING BRACKET KIT	SEE FOOTNOTE 5.
	117-881	1	HOSE CARRIER	OBSOLETE
	499-563	-	REPAIR SECTION, 4-LINK	SEE FOOTNOTE 1. FOR I17-881 ONLY.
	499-564	-	BAR KIT	SEE FOOTNOTE 2. FOR I17-881 ONLY.
	499-565	-	HARDWARE KIT	SEE FOOTNOTE 3. FOR I17-881 ONLY.
	499-566	-	EXTENDER KIT	SEE FOOTNOTE 4. FOR I17-881 ONLY.
	499-568	-	EASY OUT BAR KIT	SEE FOOTNOTE 6. FOR I17-881 ONLY.
6.	107-566	4	CARRIAGE BOLT (3/8-NC X 1.50")	
7.	117-995	1	ABRASION SLEEVE (2.07" X 156")	SEE FOOTNOTE 7.
8.	110-333	1	BOLT-ON CLAMP (1")	SEE FOOTNOTE 7.
9.	117-378	1	BULK HOSE, LOW PRESSURE (-12)	USE I47.0". SEE FOOTNOTE 7.
10.	105-814	6	FLG LOCKNUT (3/8-NC)	
11.	300-8896	1	LEFT MOUNT BRACKET	
12.	300-8895	1	RIGHT MOUNT BRACKET	
13.	362-1408	2	CAP PLATE	
14.	362-1407	1	CENTER PLATE	
15.	105-081	6	BOLT (3/8-NC X 3-1/4")	

NOT SHOWN:

150-1701	A	HOSE (060FX-280"-3000)	
150-1700	B	HOSE (040FX45-282"-3000)	
150-1980	C	HOSE (040FX-282"-3000)	
150-1979	D	HOSE (080FX-289"-3000)	
150-1700	E	HOSE (040FX45-282"-3000)	AT ONLY
150-1709	F	HOSE(060FX45-302"-3000)	
215-1358	G	HOSE TRACK HARNESS	
150-1702	H	HOSE (160FX90S-299"-6000)	
150-1705	J	HOSE(200FX90L-300"-3000)	
150-1708	K	HOSE(200FX90S-283"-3000)	
150-1704	L	HOSE(200FX90S-287"-3000,SPEC)	
150-1702	M	HOSE (160FX90S-299"-6000)	

FOOTNOTES:

- 4-LINK REPAIR SECTION SUPPLIED ASSEMBLED WITH 8X LINK PINS AND SNAP RINGS SHIPPED LOOSE
- KIT CONTENTS: 8X ALUMINUM FLAT BARS, 32X 10-24 UNC SCREWS
- KIT CONTENTS: 8X LINK PINS, 8X LINK PIN SNAP RINGS
- KIT CONTENTS: 8X WINDOW EXTENDERS, 8X 1/4-20 UNC SCREWS AND NUTS
- KIT CONTENTS: 2X RIGHT AND LEFT MOUNTING BRACKETS, 8X LINK PINS, 8X LINK PIN SNAP RINGS
- KIT CONTENTS: 10X EASY-OUT BAR
- NOT USED ON 4020 WITH RACK AND PINION.

NOTE:

CLAMP ASSEMBLY AT42M1

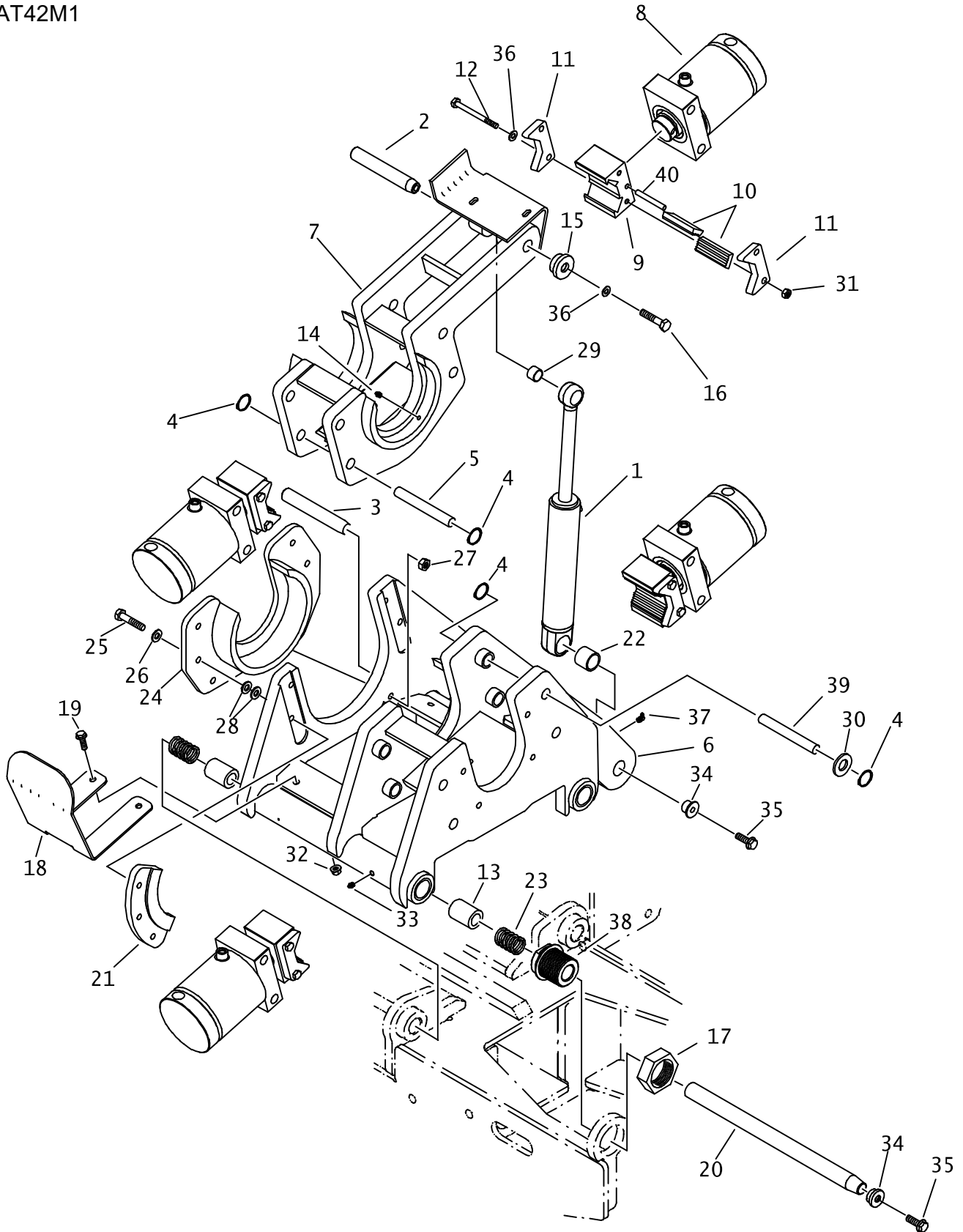

CLAMP ASSEMBLY

AT42M1

REF NO.	PART NUMBER	QTY	DESCRIPTION	REMARKS
1.	151-031	1	CYL (2" X 1" X 8")	
2.	184-789	1	TAPERED PIN (25.4MM X 158.7MM)	
3.	178-075	1	TAPERED PIN (31.7MM X 240MM)	
4.	118-053	16	EXTERNAL SNAP RING (.875")	
5.	105-1133	4	PIN	APPLY ANTI-SEIZE TO PIN
6.	313-716	1	STATIONARY CLAMP	
7.	313-717	1	ROTATION CLAMP	
8.	151-212	4	CYL (4.50" X 2.25" X 2.75")	
9.	314-747	4	JAW BLOCK	
10.	350-446	8	GRIPPER INSERT	AT PIPE
	320-155	-	GRIPPER INSERT	JT PIPE
11.	313-881	8	PLATE	
12.	105-022	8	BOLT (3/8-NC X 4")	
13.	178-456	4	BUSHING 1.26ID X 1.75OD X 1.75	
14.	115-003	8	ZERK (1/4-NF, STR)	
15.	181-981	1	TAPERED INSERT (1")	
16.	105-245	1	SCREW (M10-1.50 X 25MM)	
17.	105-695	2	NUT (2 3/8-16 UNJ)	LOCTITE 242
18.	310-114	1	PLATE	
19.	106-383	2	FLG LK SCREW (M10-1.50 X 30MM)	
20.	178-906	2	TAPERED PIN (1.250" X 25.310")	
21.	314-363	2	BACKUP PLATE	
22.	125-771	1	COMPOSITION BUSHING (1.25")	
23.	117-297	4	COMPRESSION SPRING	
24.	313-715	1	RETAINER	
25.	106-659	7	SCREW (M12-1.75 X 55MM)	LOCTITE 242
26.	106-397	7	WASHER (M12, HARDENED)	
27.	106-685	1	LOCKNUT(M12-1.75,PRV TRQ,10.9)	
28.	110-096	14	MACHINERY BUSHING (1/2")	
29.	125-770	1	COMPOSITION BUSHING (1")	
30.	105-318	AR	WASHER (7/8")	INSTALL WASHERS SO THAT SLACK IS REMOVED
31.	105-047	8	LOCKNUT (3/8-NC)	LOCTITE 242
32.	106-387	2	FLG LOCKNUT (M10-1.50)	
33.	115-001	1	ZERK (O2N)	
34.	181-982	3	TAPERED INSERT (1.25")	
35.	106-469	3	FLG SCREW (M12-1.75 X 30MM)	
36.	106-396	8	WASHER (M10, HARDENED)	
37.	115-004	1	ZERK (O2N45)	
38.	178-283	2	BOSS	
39.	105-1134	4	PIN	APPLY ANTI-SEIZE TO PIN
40.	107-777	4	SPIRAL SPRING PIN (.375" X 3.00")	

NOT SHOWN:

FOOTNOTES:

NOTE:

WRENCH PIPE GUIDE

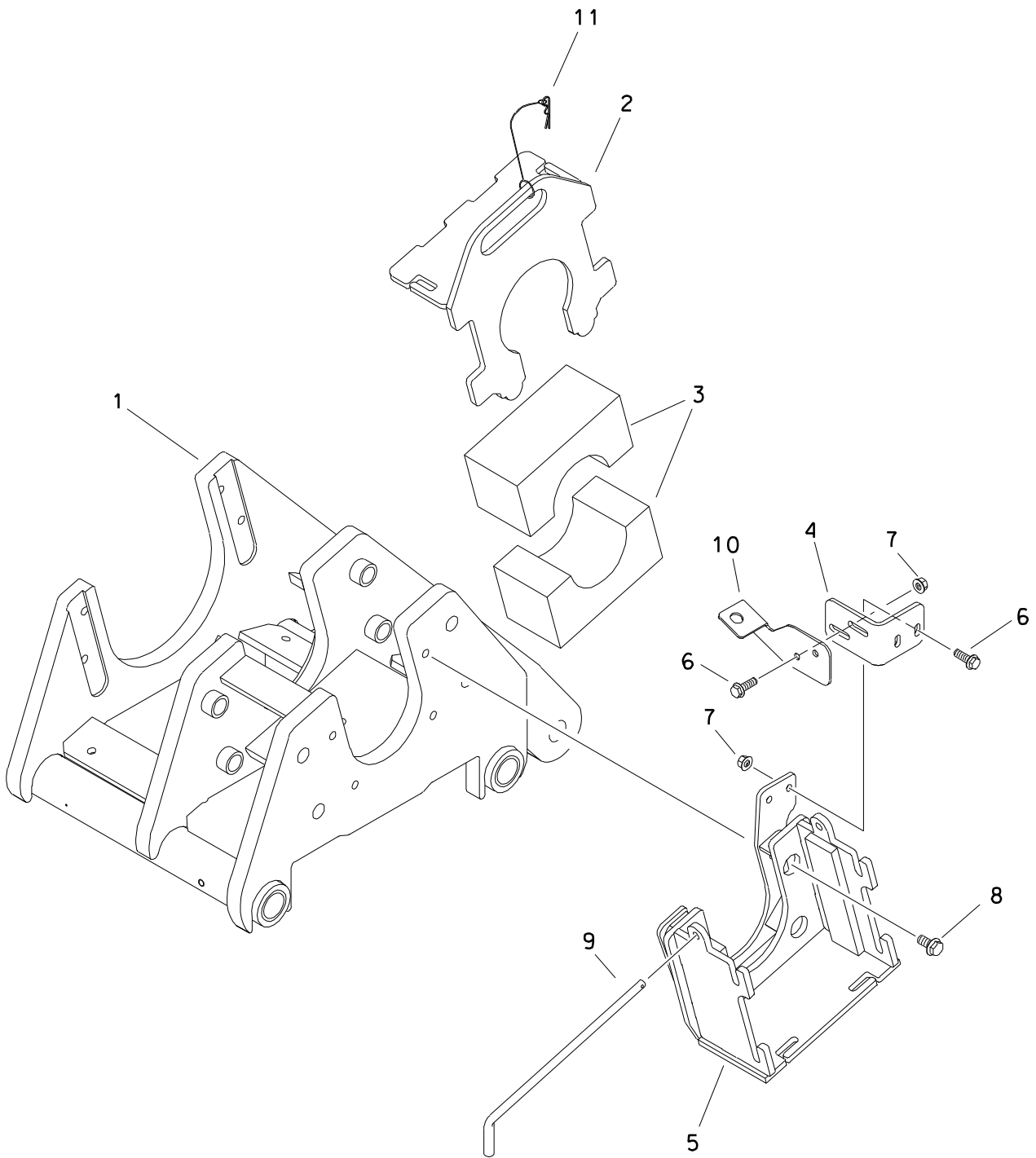

WRENCH PIPE GUIDE

REF NO.	PART NUMBER	QTY	DESCRIPTION	REMARKS
1.	313-716	-	STATIONARY CLAMP	
2.	313-761	1	BLOCK RETAINER	
3.	314-359	2	GUIDE BLOCK (4.13)	AT PIPE
	314-360	2	GUIDE BLOCK (3.50)	JT PIPE
4.	316-742	1	BRACKET, SPRAY	
5.	313-760	1	WRENCH GUIDE FRAME	
6.	106-724	4	FLG SCREW (M10-1.50 X 25MM)	
7.	106-387	4	FLG LOCKNUT (M10-1.50)	
8.	106-806	4	FLG LK SCREW (M12-1.75 X 25MM)	
9.	346-061	1	PIN	
10.	318-854	1	BRACKET, SPRAY	
11.	110-410	1	SAFETY CLIP & LANYARD	

FOOTNOTES

HYDRAULIC CYLINDER (4.50" X 2.25" X 2.75")

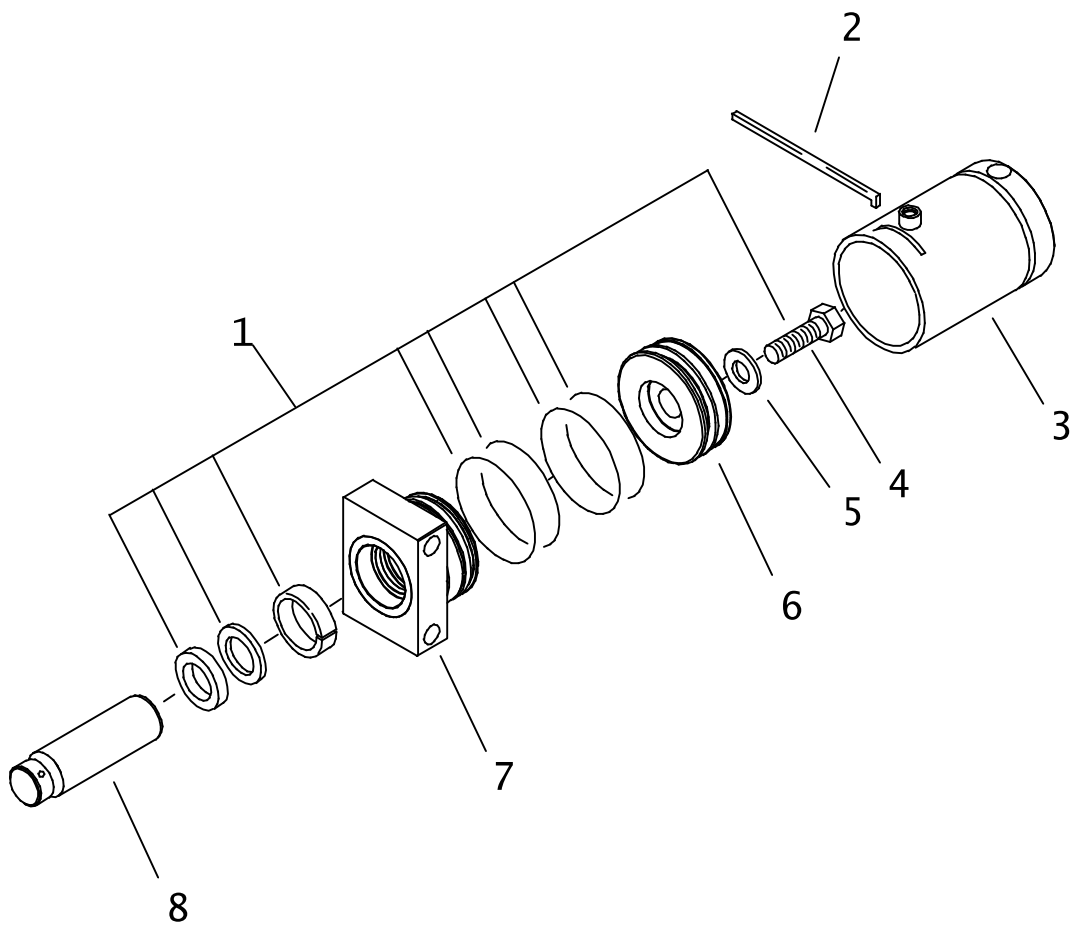

HYDRAULIC CYLINDER (4.50" X 2.25" X 2.75")

REF NO.	PART NUMBER	QTY	DESCRIPTION	REMARKS
	151-212		CYLINDER ASSEMBLY	INCLUDES REF NO'S 2 THRU 8
1.	190-900	1	SEAL REPAIR KIT	
2.	150-711	1	LOCK RING	
3.	152-073	1	4.5 X 2.75 BARREL	
4.	106-146	1	BOLT (1-1/8-NC X 2-1/2", GD8)	SEE FOOTNOTE 1
5.	106-147	1	WASHER (1-1/8")	
6.	149-168	1	4.5 X 2.25 PISTON	SEE FOOTNOTE 2
7.	151-207	1	GLAND	
8.	153-753	1	CYLINDER ROD	

NOT SHOWN

259-040 U-SEAL INSTALLER (1.500" - UP)

FOOTNOTES

1. USE LOCTITE 271 OR 277. TORQUE TO 770-850 FT-LBS (1045-1150 N.M.).
2. UNITIZED PISTON INCLUDES WEAR RINGS, SQUARE LOADER RING & PISTON SEAL.

NOTE:

NOTES:

PIPE LOADER SYSTEMS

PIPE LOADER SHUTTLE DRIVE

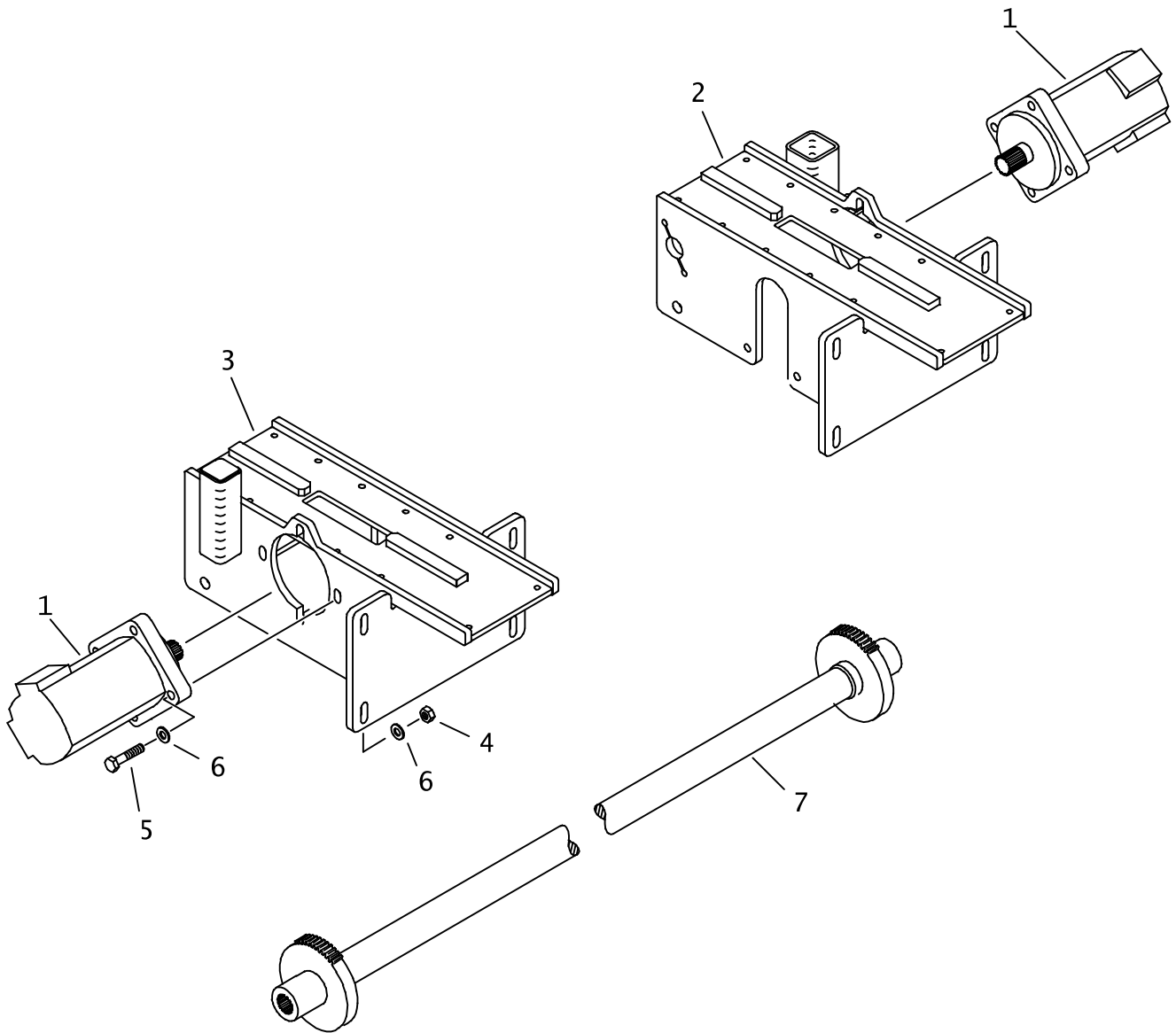

PIPE LOADER SHUTTLE DRIVE

REF NO.	PART NUMBER	QTY	DESCRIPTION	REMARKS
1.	158-026	2	HYDRAULIC MOTOR (15 CU/IN)	
	500-1552	-	SEAL REPAIR KIT	
	500-1553	-	SHAFT AND BEARING KIT	
	500-711	-	SEAL REPAIR KIT, REAR	
	500-758	-	SEAL REPAIR KIT, SHAFT	
2.	307-591	-	FRONT SHUTTLE SUPPORT	
	327-1063	-	FRONT SHUTTLE SUPPORT	SEE FOOTNOTE I
3.	307-592	-	REAR SHUTTLE SUPPORT	
	327-1064	-	REAR SHUTTLE SUPPORT	SEE FOOTNOTE I
4.	106-685	8	LOCKNUT (M12-1.75, PRV TRQ, 10.9)	
5.	106-594	8	SCREW (M12-1.75 X 60MM)	
6.	106-397	16	WASHER (M12, HARDENED)	
7.	313-969	1	PINION SHAFT	

NOT SHOWN:

FOOTNOTES:

I. USE ON 4020 WITH RACK AND PINION

NOTE:

PIPE LOADER LIFTERS

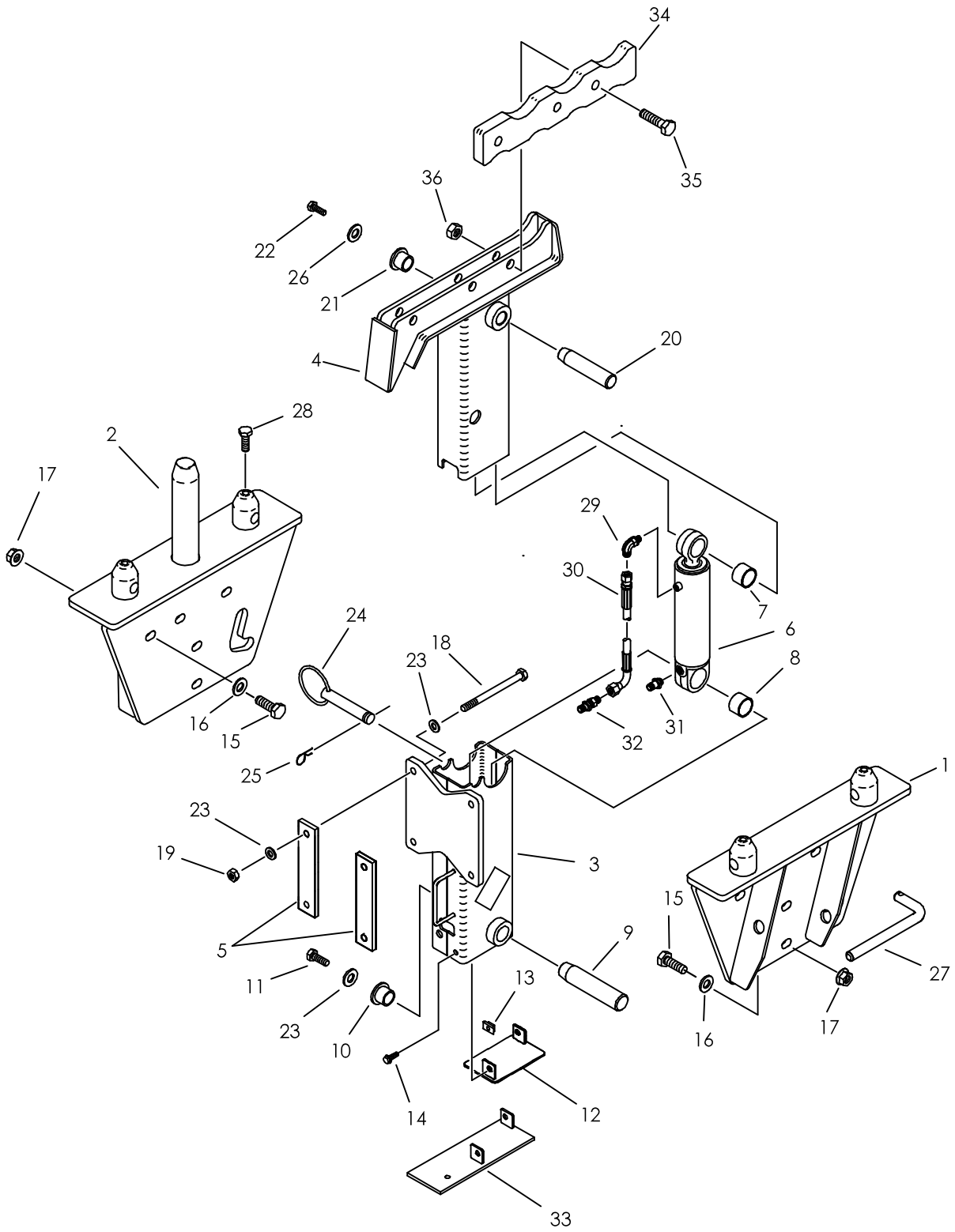

PIPE LOADER LIFTERS

REF NO.	PART NUMBER	QTY	DESCRIPTION	REMARKS
1.	313-792	1	FRONT BOX SUPPORT	
2.	313-791	1	REAR BOX SUPPORT	
3.	313-783	2	LIFTER OUTER TUBE	
4.	313-805	2	PIPE LIFTER	
	327-1069	2	PIPE LIFTER	SEE FOOTNOTE 2
5.	354-338	4	MOUNT PLATE	
6.	151-031	2	CYL (2.0" X 1.00" X 8.000")	
7.	125-770	2	COMPOSITION BUSHING (1")	
8.	125-771	2	COMPOSITION BUSHING (1.25")	
9.	183-863	2	TAPERED PIN (31.7MM X 128MM)	
10.	181-982	2	TAPERED INSERT (1.25")	
11.	105-273	2	SCREW (M12-1.75 X 30mm)	
12.	356-297	1	STABILIZER CAP	REAR LIFTER
13.	106-551	4	CLIP NUT (M8-1.25)	
14.	106-991	4	FLG LK SCREW (M8-1.25 X 20mm)	
15.	106-340	10	SCREW (M16-2.00 X 50mm)	
16.	106-398	10	WASHER (M16, HARDENED)	
17.	106-442	10	FLG LOCKNUT (M16-2.00, PRV TRQ)	
18.	106-620	8	SCREW (M12-1.75 X 150mm)	
19.	106-685	8	LOCKNUT (M12-1.75, PRV TRQ, 10.9)	
20.	179-024	2	TAPERED PIN (25.4MM X 117MM)	
21.	181-981	2	TAPERED INSERT (1.00")	
22.	105-245	2	SCREW (M10-1.50 X 25mm)	
23.	106-397	18	WASHER (M12, HARDENED)	
24.	180-559	2	PULL PIN (1" X 4.625")	
25.	110-128	2	SPRING CLIP PIN (5/32" X 1")	
26.	106-396	2	WASHER (M10, HARDENED)	
27.	178-446	2	PIPE ROTATION PIN	JT ONLY
28.	106-477	4	SCREW (M12-1.75 X 45MM, 10.9)	
29.	154-252	-	CONNECTOR (04S-04090)	
30.	515-179	-	HOSE (040FX90-11"-3000)	
31.	154-403	-	CONNECTOR (04S-040, XL)	
32.	154-275	-	BK CONNECTOR (040-040BK)	
33.	306-741	1	CAP	FRONT LIFTER
34.	313-782	2	PIPE LIFTER INSERT	SEE FOOTNOTE 1
	300-7416	2	PIPE LIFTER INSERT	SEE FOOTNOTE 1 & 2
35.	106-341	6	SCREW (M16-2.00 X 70MM)	
36.	106-545	6	LOCKNUT (M16-2.0, PRV TRQ, 10.9)	

NOT SHOWN:

FOOTNOTES:

- PIPE LIFTER INSERT IS REVERSABLE. SIDE W/ 3 NOTCHES IS FOR THE AT, SIDE W/ 4 NOTCHES IS FOR JT.
- USE ON 4020 WITH RACK AND PINION.

NOTE:

FRONT PIPE LOADER SHUTTLE

JT42 T3, AT42 T3

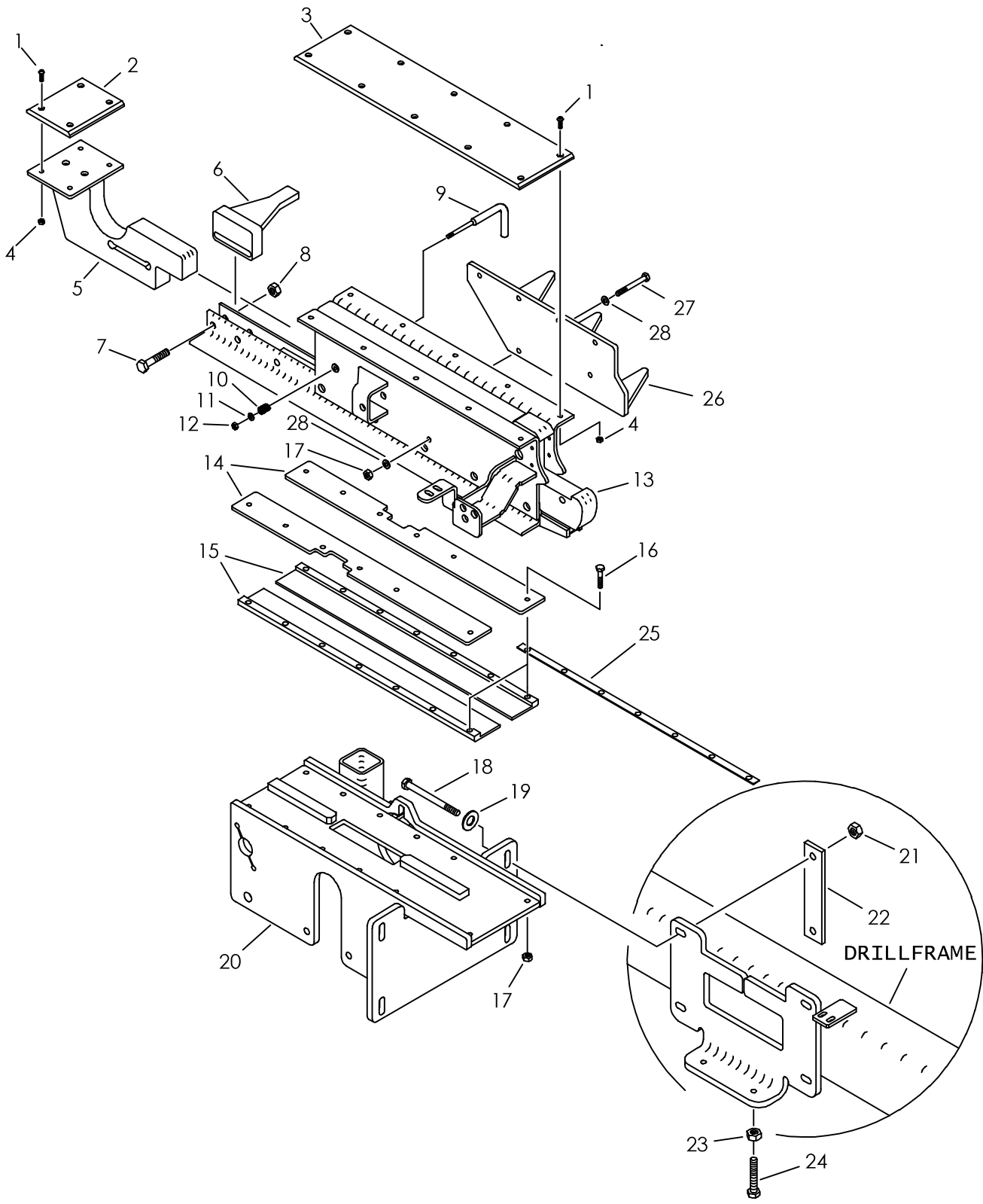

FRONT PIPE LOADER SHUTTLE

JT42 T3, AT42 T3

REF NO.	PART NUMBER	QTY	DESCRIPTION	REMARKS
1.	106-640	14	SCREW (M6-1.00 X 20MM,BUT SOC)	
2.	307-623	1	PIPE SLIDE BEARING	
3.	315-112	1	PIPE SLIDE BEARING	
4.	106-237	14	LOCKNUT (M6-1.00,PRV TRQ,NLK)	
5.	313-685	1	SINGLE PIPE LOADER	
6.	307-594	1	SHUTTLE STOP	
7.	106-659	2	SCREW (M12-1.75 X 55MM)	
8.	106-685	2	LOCKNUT(M12-1.75,PRV TRQ,10.9)	
9.	178-414	1	SHOULDER PIN	
10.	117-116	1	COMPRESSION SPRING	
11.	105-095	1	WASHER (1/4")	
12.	105-085	1	LOCKNUT (1/4-NC)	
13.	313-683	1	FRONT SHUTTLE	
14.	307-605	2	PLATE	
15.	307-621	2	SHUTTLE SLIDE BEARING	
16.	106-328	12	SCREW (M8-1.25 X 40MM)	
17.	106-561	17	LOCKNUT (M8-1.25,PRV TRQ,10.9)	
18.	107-213	4	SCREW (M12-1.75 X 160MM)	
19.	106-397	4	WASHER (M12, HARDENED)	
20.	307-591	1	FRONT SHUTTLE SUPPORT	
	327-1063	1	FRONT SHUTTLE SUPPORT	SEE FOOTNOTE I
21.	106-685	4	LOCKNUT(M12-1.75,PRV TRQ,10.9)	
22.	354-338	2	MOUNT PLATE	
23.	106-089	2	NUT (M12-1.75, 10.9)	
24.	107-701	2	SCREW (M12-1.75 X 100MM)	
	105-1079	2	SCREW (M12-1.75 X 140MM)	SEE FOOTNOTE I
25.	117-539	AR	SHIM	USE ONLY IF PLASTIC IS TOO THIN
26.	313-701	1	AT ROW SELECT	
	313-702	1	JT ROW SELECT	
27.	105-292	5	SCREW (M8-1.25 X 75MM)	
28.	106-395	10	WASHER (M8, HARDENED)	

NOT SHOWN:

FOOTNOTES:

I. USE ON 4020 WITH RACK AND PINION

NOTE:

REAR PIPE LOADER SHUTTLE AT42M1

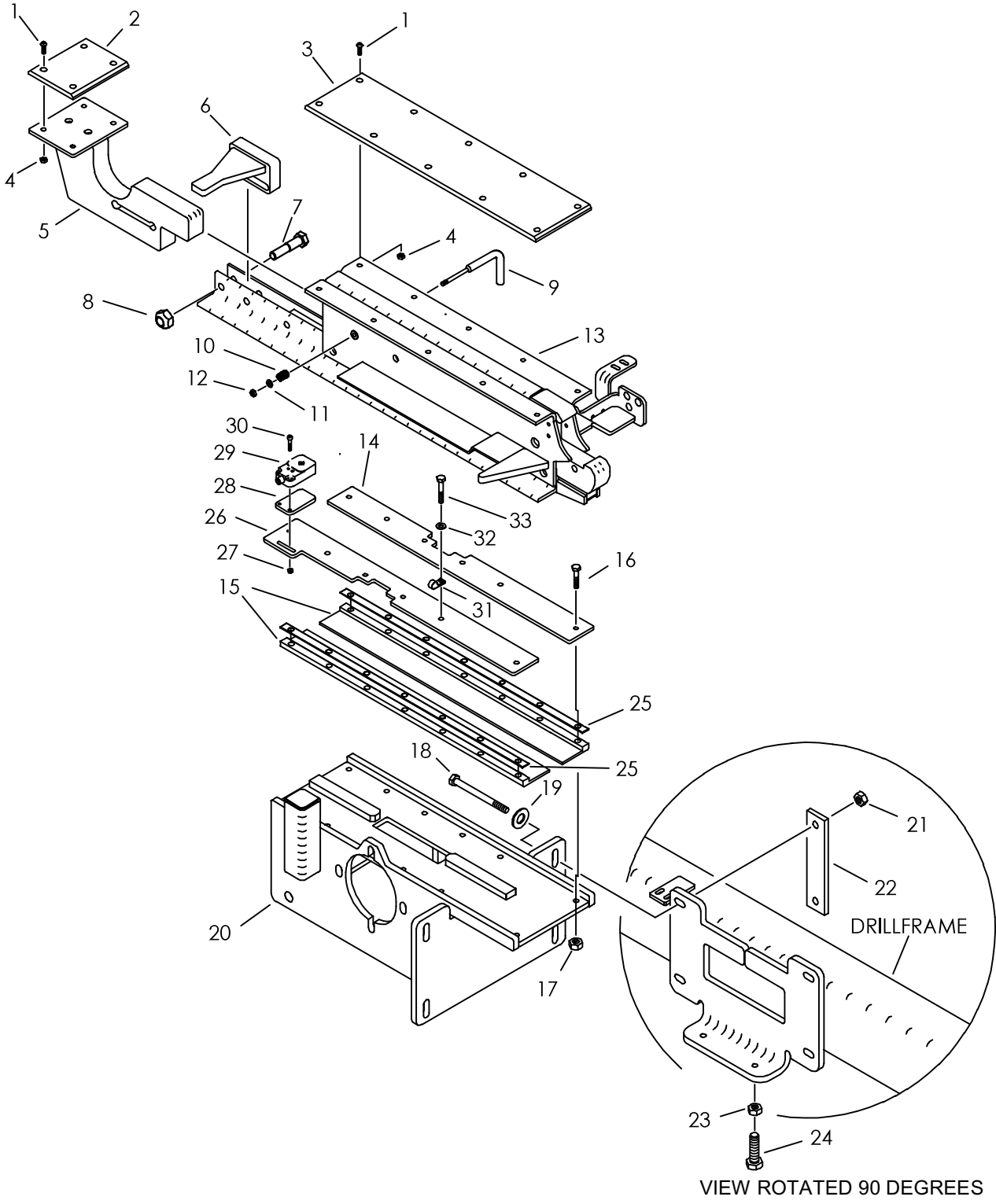

REAR PIPE LOADER SHUTTLE AT42M1

REF NO.	PART NUMBER	QTY	DESCRIPTION	REMARKS
1.	106-640	14	SCREW (M6-1.00 X 20MM,BUT SOC)	
2.	307-623	1	PIPE SLIDE BEARING	
3.	315-112	1	PIPE SLIDE BEARING	
4.	106-237	14	LOCKNUT (M6-1.00,PRV TRQ,NLK)	
5.	313-685	1	SINGLE PIPE LOADER	
6.	307-594	1	SHUTTLE STOP	
7.	106-659	2	SCREW (M12-1.75 X 55MM)	
8.	106-685	2	LOCKNUT(M12-1.75,PRV TRQ,10.9)	
9.	178-414	1	SHOULDER PIN	
10.	117-116	1	COMPRESSION SPRING	
11.	105-095	1	WASHER (1/4")	
12.	105-085	1	LOCKNUT (1/4-NC)	
13.	313-684	1	REAR SHUTTLE	
14.	307-605	1	PLATE	
15.	307-621	2	SHUTTLE SLIDE BEARING	
16.	106-328	11	SCREW (M8-1.25 X 40MM)	
17.	106-561	12	LOCKNUT (M8-1.25,PRV TRQ,10.9)	
18.	107-213	4	SCREW (M12-1.75 X 160MM)	
19.	106-397	4	WASHER (M12, HARDENED)	
20.	307-592	1	REAR SHUTTLE SUPPORT	
	327-1064	1	REAR SHUTTLE SUPPORT	SEE FOOTNOTE I
21.	106-685	4	LOCKNUT(M12-1.75,PRV TRQ,10.9)	
22.	354-338	2	MOUNT PLATE	
23.	106-089	2	NUT (M12-1.75, 10.9)	
24.	107-701	2	SCREW (M12-1.75 X 100MM)	
	105-1079	2	SCREW (M12-1.75 X 140MM)	SEE FOOTNOTE I
25.	117-539	AR	SHIM	USE ONLY IF PLASTIC IS TOO THIN
26.	307-947	1	PLATE	
27.	106-850	2	LOCKNUT (M5-0.80)	
28.	107-451	AR	SHIM (.135")	USE ONLY IF GAP IS TOO LARGE
29.	215-1175	-	PROXIMITY SENSOR	
30.	107-465	2	SCREW (M5-0.80 X 30MM, SOC)	
31.	110-259	1	BOLT-ON CLAMP (.625")	
32.	106-389	1	WASHER (M8)	
33.	106-932	1	SCREW (M8-1.25 X 45MM)	

NOT SHOWN:

FOOTNOTES:

I. USE ON 4020 WITH RACK AND PINION

NOTE:

PIPE LOADER GRIPPER

JT42 T3, AT42 T3

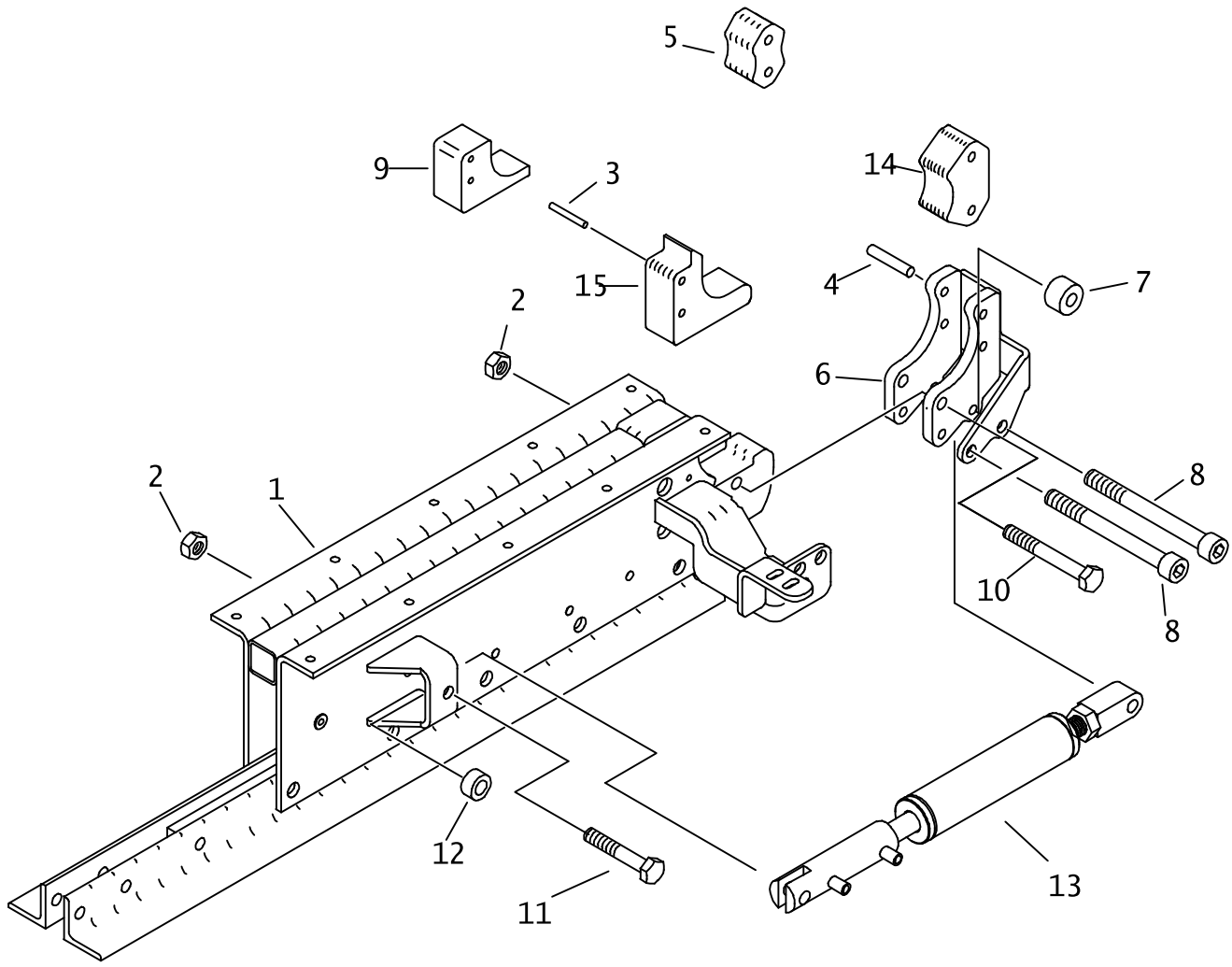

PIPE LOADER GRIPPER

JT42 T3, AT42 T3

REF NO.	PART NUMBER	QTY	DESCRIPTION	REMARKS
1.	313-683	1	FRONT SHUTTLE	
	313-684	1	REAR SHUTTLE	
2.	105-065	4	LOCK NUT (1/2-NC)	
3.	105-503	4	ROLL PIN (1/4" X 2")	
4.	105-555	4	ROLL PIN (3/8" X 2-1/2")	
5.	313-705	2	GRIPPER PAD	USE WITH AT PIPE
6.	313-686	1	FRONT GRIPPER	
	313-687	1	REAR GRIPPER	
7.	307-614	2	ROLLER	
8.	107-613	4	SHLD BLT M12 X 40MM, M10-1.50,SP	LOCTITE 277
9.	313-704	2	SHUTTLE PAD	USE WITH AT PIPE
10.	105-300	2	BOLT (1/2-NC X 3-1/4")	
11.	105-472	2	BOLT (1/2-NC X 5")	
12.	354-354	2	SPACER	
13.	191-161	2	GRIPPER CYLINDER	
14.	319-369	2	GRIPPER PAD	USE WITH JT PIPE
15.	319-368	2	SHUTTLE PAD	USE WITH JT PIPE

NOT SHOWN:

FOOTNOTES:

NOTE:

GRIPPER CYLINDER

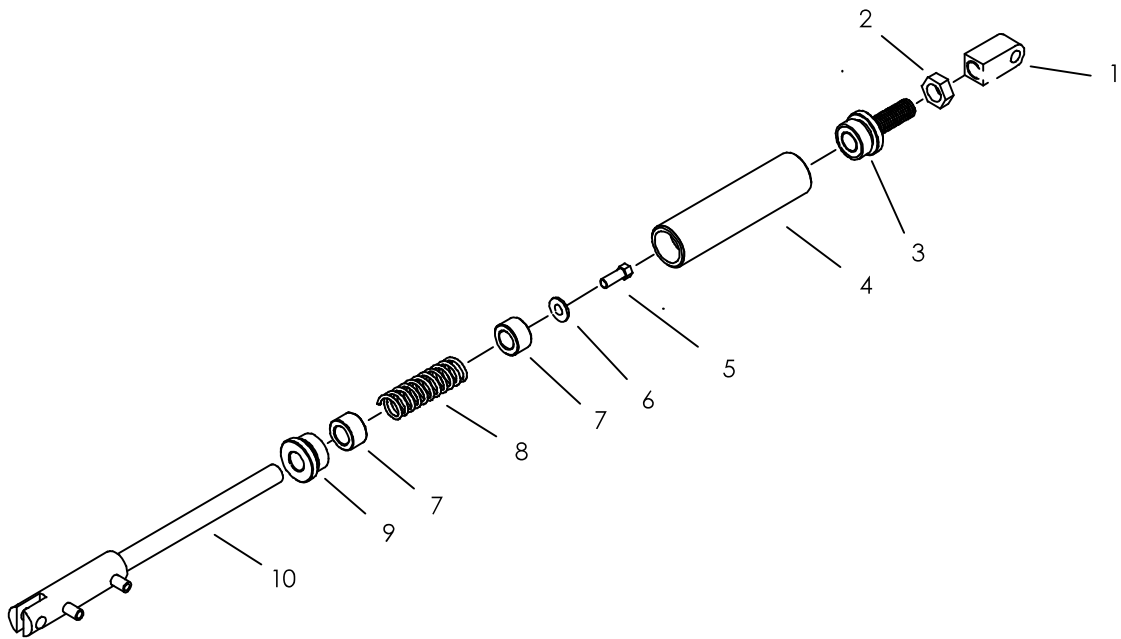

GRIPPER CYLINDER

REF NO.	PART NUMBER	QTY	DESCRIPTION	REMARKS
	191-161		GRIPPER CYLINDER	INCL. REF. NO.'S 1 THRU 10
1.	354-357	1	ROD END	
2.	105-310	1	JAM NUT (3/4-NC)	
3.	354-323	1	PLUNGER	
4.	354-355	1	TUBE	
5.	105-031	1	BOLT (3/8-NC X 1")	LOCKTITE 242
6.	105-118	1	WASHER (3/8")	
7.	354-356	2	SPRING GUIDE	
8.	117-180	1	COMPRESSION SPRING	
9.	354-432	1	CAP	
10.	150-731	1	CYL ASS'Y	USE HIGH TEMP PHILLIP GREASE ON ROD

NOT SHOWN:

FOOTNOTES:

NOTE:

SHUTTLE STOP

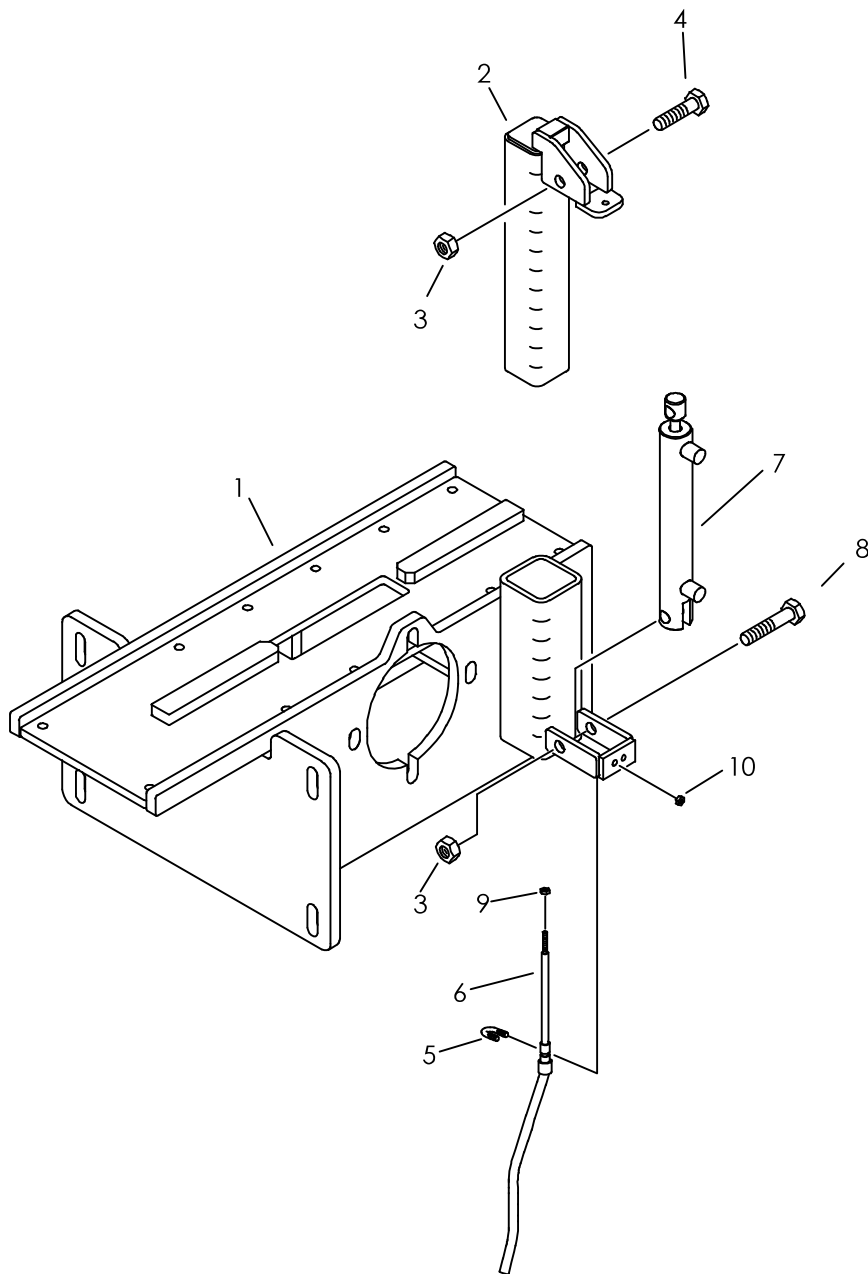

SHUTTLE STOP

REF NO.	PART NUMBER	QTY	DESCRIPTION	REMARKS
1.	327-1063	-	FRONT SHUTTLE SUPPORT	SEE FOOTNOTE 1
2.	308-344	1	STOP TUBE WELDMENT	
3.	105-065	2	LOCKNUT (1/2-NC)	
4.	105-002	1	BOLT (1/2-NC X 2-1/4")	
5.	106-630	1	U-BOLT (#10-24 X 5/16")	
6.	196-286	1	CONTROL CABLE	
7.	150-727	1	CYL (1.0" X .500" X 4.0")	
8.	105-067	1	BOLT (1/2-NC X 2-3/4")	
9.	106-138	2	NUT (M5-0.80)	
10.	105-186	2	NUT (#10-24)	

NOT SHOWN:

FOOTNOTES:

- 1. USE ON 4020 WITH RACK & PINION

NOTE:

SHUTTLE STOP INDICATOR

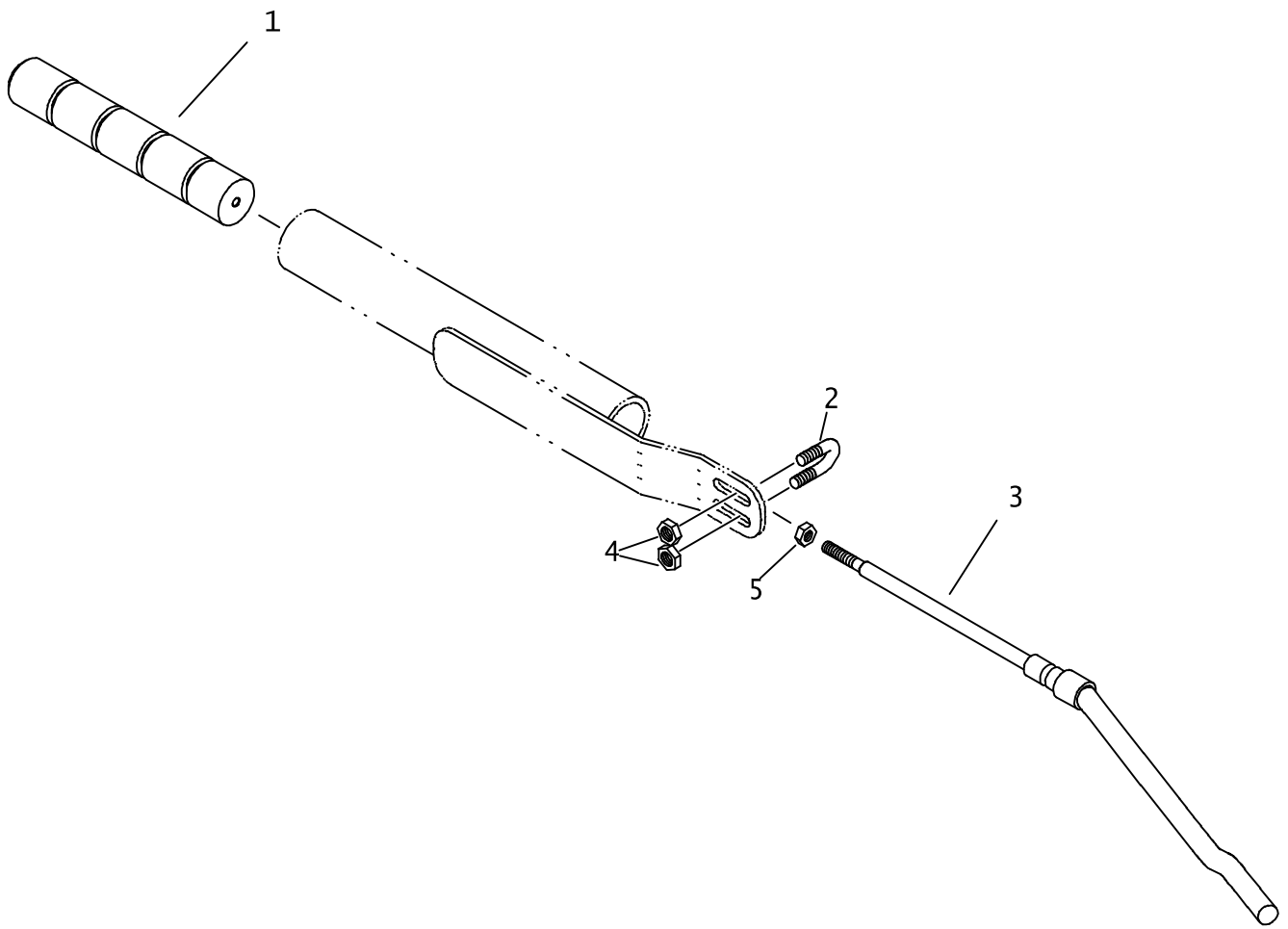

SHUTTLE STOP INDICATOR

REF NO.	PART NUMBER	QTY	DESCRIPTION	REMARKS
1.	258-032	1	ROW SELECT INDICATOR	
2.	106-630	1	U-BOLT (#10-24 X 5/16")	
3.	196-286	-	CONTROL CABLE	
4.	105-186	2	NUT (#10-24)	
5.	106-138	1	NUT (M5-0.80)	

NOT SHOWN:

FOOTNOTES:

NOTE:

PIPE BOX AT42T2 PIPE

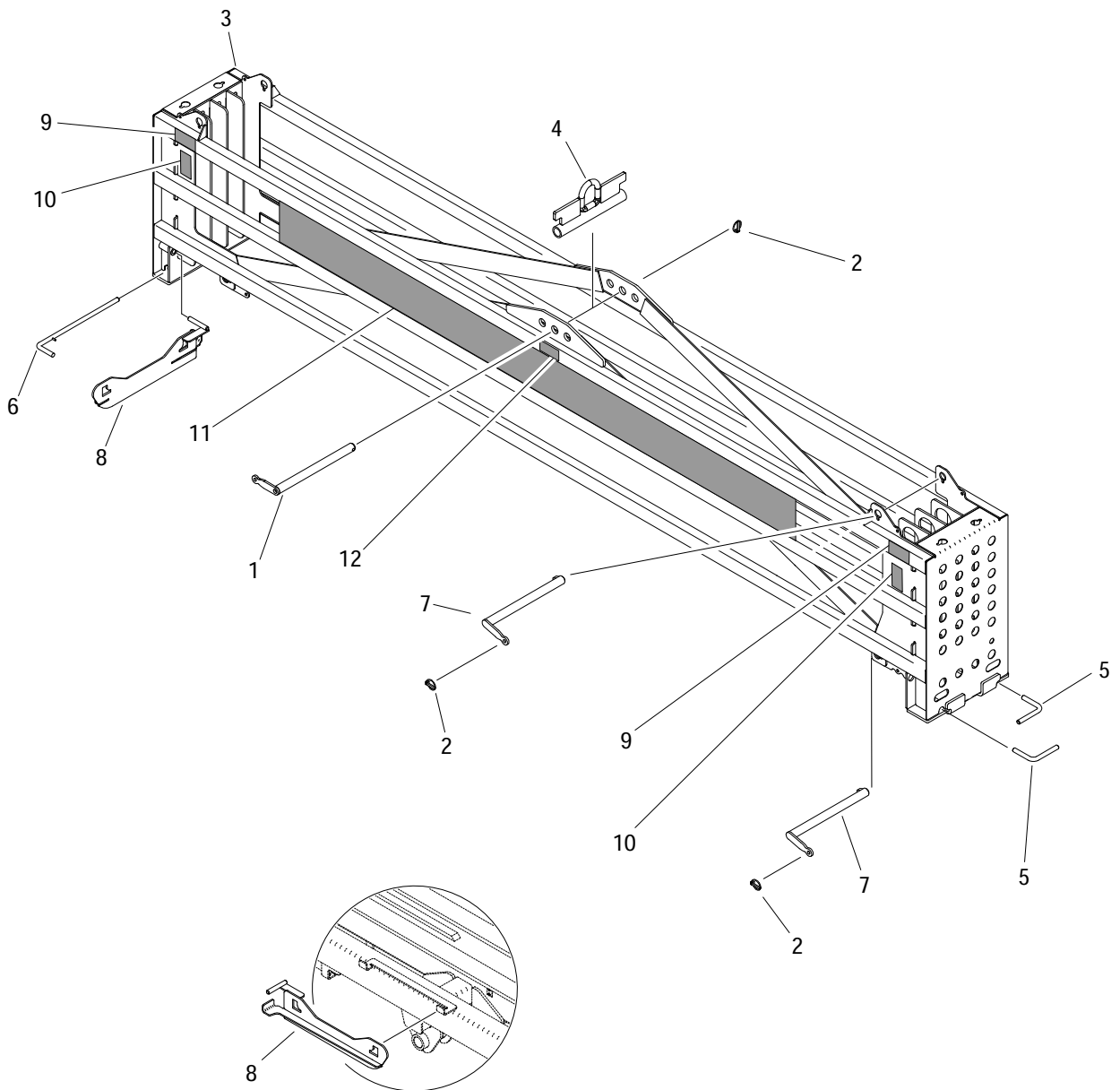
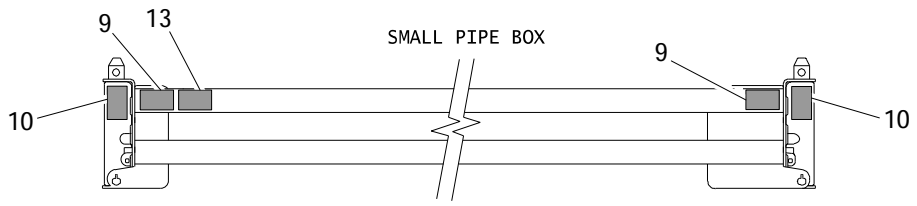

PIPE BOX AT42T2 PIPE

REF NO.	PART NUMBER	QTY	DESCRIPTION	REMARKS
	315-982		LARGE PIPE BOX ASS'Y	PARTS ASSEMBLY, INCLUDES ITEMS 1-12
	315-981		SMALL PIPE BOX PARTS ASS'Y	PARTS ASSEMBLY, INCLUDES ITEMS 1-10 & #13.
1.	308-084	1	LIFT PIN	
2.	110-228	5	LYNCH PIN (7/16"x2")	
3.	313-939	1	AT4020 PIPE BOX (TALL)	PART OF 315-982
	313-955	1	AT4020 PIPE BOX (SHORT)	PART OF 315-981
4.	314-574	1	LIFT PIN BLOCK	
5.	178-445	2	REAR PIN	
6.	308-091	1	FRONT PIN	
7.	308-086	4	SUPPORT PIN	
8.	308-868	1	SINGLE PIPE GUIDE	
9.	275-326	4	WARNING CRUSHING WEIGHT	USE 701-326 IN ALL FOREIGN KITS
10.	275-184	4	WARNING MOVING PARTS	USE 701-184 IN ALL FOREIGN KITS
11.	273-596	1	JT4020AT PIPE BOX MODEL-ID	
12.	273-373	1	LG PIPE BOX WEIGHTS	PART OF 315-982
13.	273-372	1	SM PIPE BOX WEIGHTS	PART OF 315-981

FOOTNOTES

PIPE BOX JT42T2 PIPE

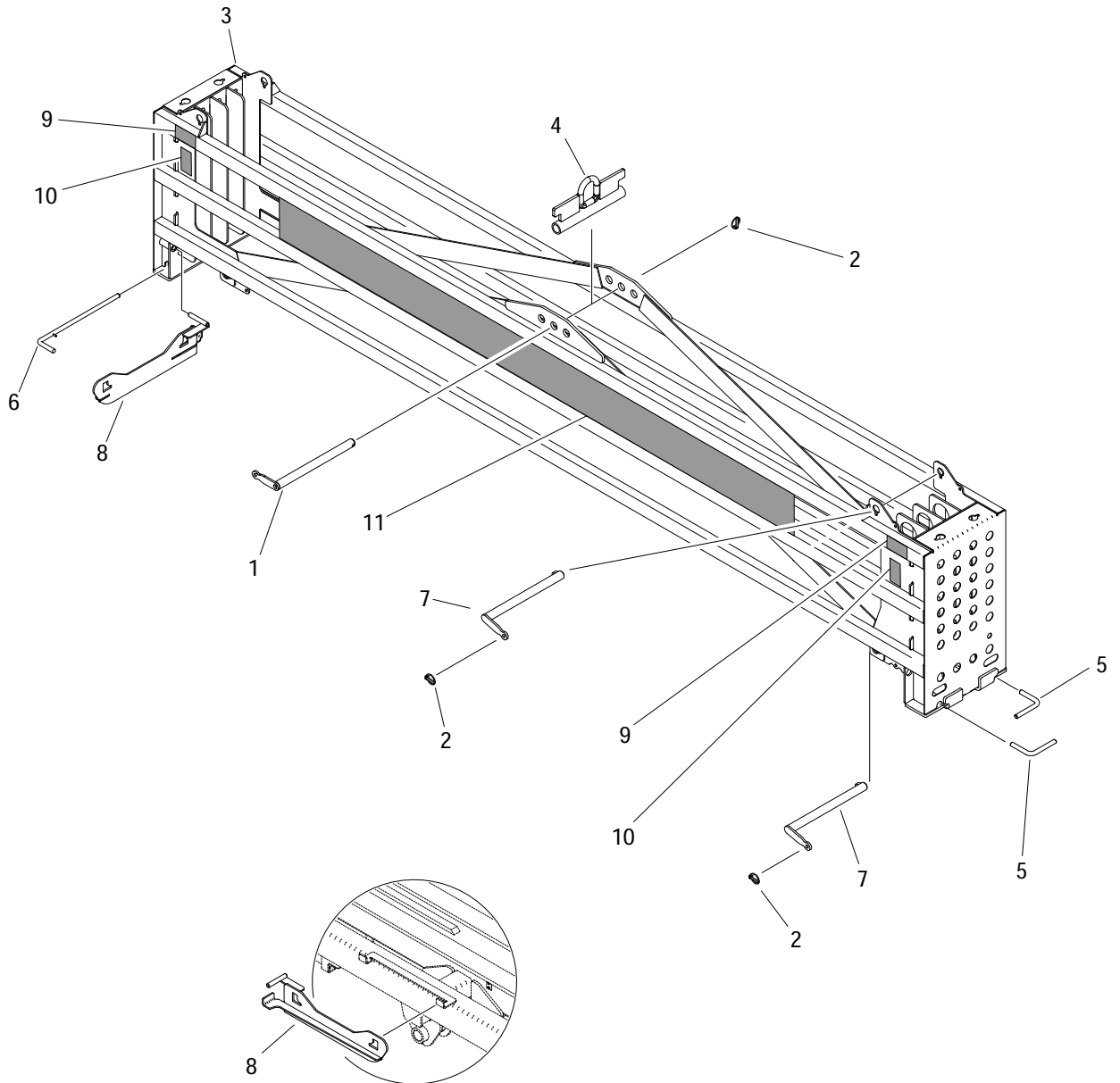
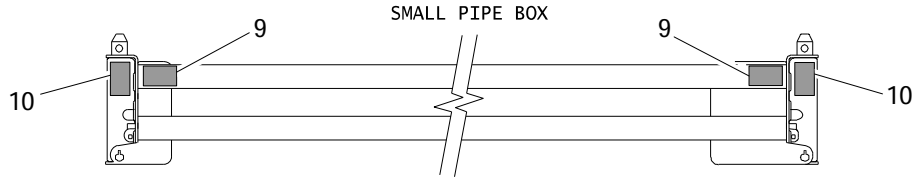

PIPE BOX JT42T2 PIPE

REF NO.	PART NUMBER	QTY	DESCRIPTION	REMARKS
	310-361		LARGE PIPE BOX	PARTS ASSEMBLY, INCLUDES ITEMS 1-11
	309-912		SMALL PIPE BOX	PARTS ASSEMBLY, INCLUDES ITEMS 1-10
1.	308-084	1	LIFT PIN	
2.	110-228	5	LYNCH PIN (7/16"X2")	
3.	308-082	1	PIPE BOX	PART OF 310-361
	309-709	1	PIPE BOX	PART OF 309-912
4.	308-083	1	LIFT PIN BLOCK	
5.	178-445	2	REAR PIN	
6.	308-091	1	FRONT PIN	
7.	308-086	4	SUPPORT PIN	
8.	308-868	1	SINGLE PIPE GUIDE	
9.	275-326	4	WARNING CRUSHING WEIGHT	USE 701-326 IN ALL FOREIGN KITS
10.	275-184	4	WARNING MOVING PARTS	USE 701-184 IN ALL FOREIGN KITS
11.	273-538	1	MODEL ID W/ LOGOTYPE	

FOOTNOTES

SHUTTLE GUARD

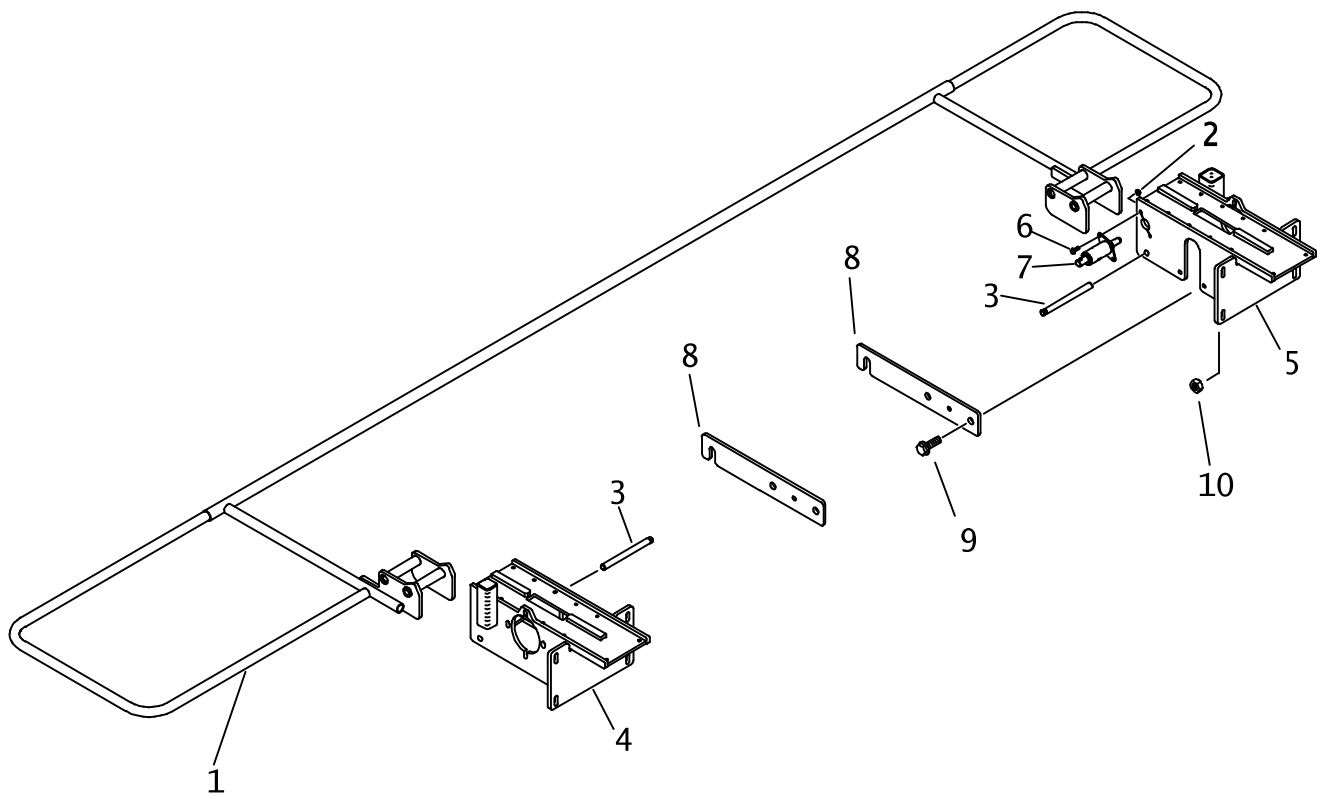

SHUTTLE GUARD

REF NO.	PART NUMBER	QTY	DESCRIPTION	REMARKS
1.	313-968	1	SHUTTLE GUARD	
2.	106-561	2	LOCKNUT (M8-1.25,PRV TRQ,10.9)	
3.	178-415	2	PIN	
4.	307-592	-	REAR SHUTTLE SUPPORT	
	327-1064	-	REAR SHUTTLE SUPPORT	SEE FOOTNOTE I
5.	307-591	-	FRONT SHUTTLE SUPPORT	
	327-1063	-	FRONT SHUTTLE SUPPORT	SEE FOOTNOTE I
6.	106-992	2	FLG LK SCREW (M8-1.25 X 25MM)	
7.	354-571	1	GUARD LOCK PIN	
8.	307-619	2	PIN RETAINER	
9.	106-632	4	FLG LK SCR (M12-1.75X35MM,SER)	
10.	106-685	4	LOCKNUT(M12-1.75,PRV TRQ,10.9)	

NOT SHOWN:

FOOTNOTES:

USE ON 4020 WITH RACK AND PINION

NOTE:

GUARD LOCK PIN

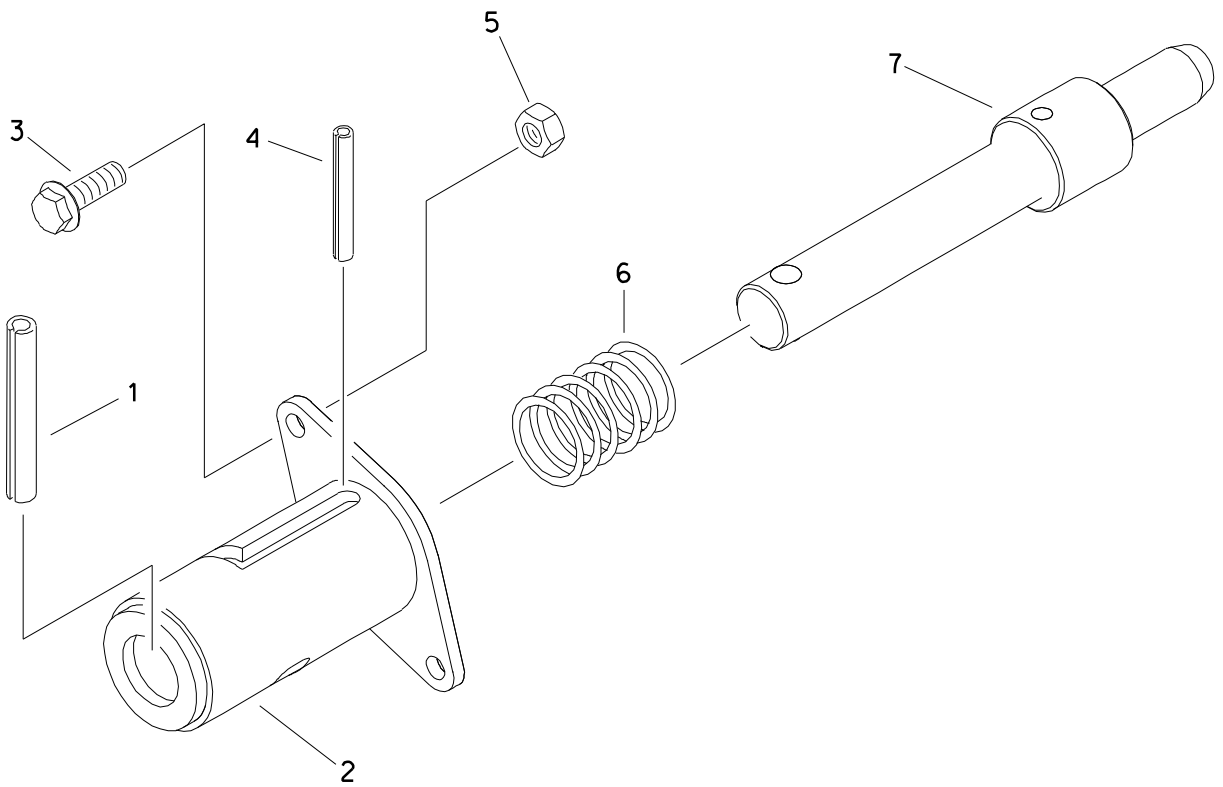

GUARD LOCK PIN

REF NO.	PART NUMBER	QTY	DESCRIPTION	REMARKS
	354-571		GUARD LOCK PIN	INCL REF NO.'S 1 THRU 7
1.	105-561	1	ROLL PIN (3/8" X 2-3/4")	
2.	354-566	1	PIN HOUSING	
3.	106-992	2	FLG LK SCREW (M8-1.25 X 25mm)	
4.	105-503	1	ROLL PIN (1/4" X 2")	
5.	106-561	2	LOCKNUT (M8-1.25, PRV TRQ, 10.9)	
6.	115-560	1	COMPRESSION SPRING	
7.	178-095	1	LOCKOUT PIN	

FOOTNOTES

NOTES:

FLUID SYSTEMS

MUD PUMP PLUMBING

120 GPM

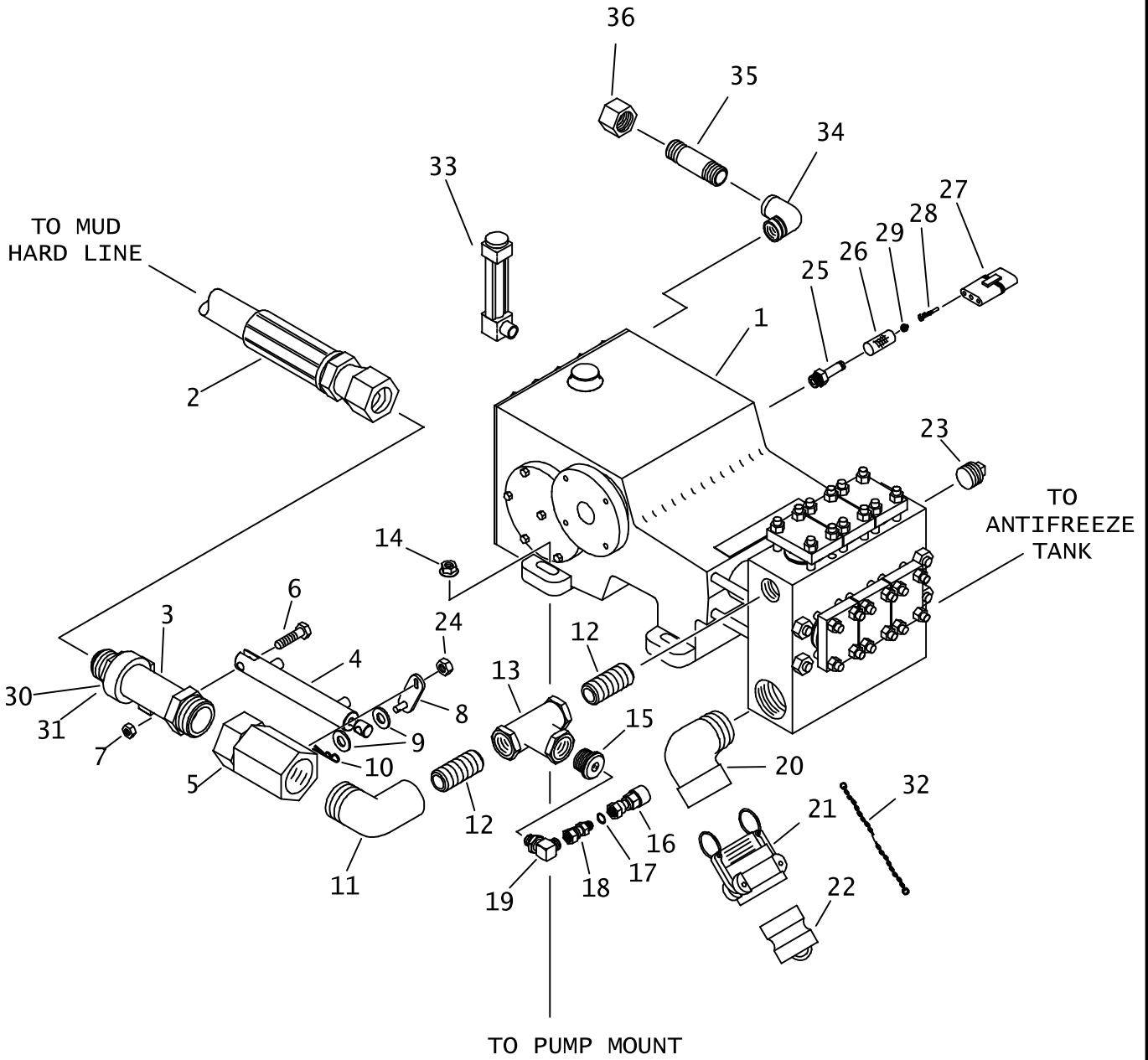

MUD PUMP PLUMBING

120 GPM

REF NO.	PART NUMBER	QTY	DESCRIPTION	REMARKS
1.	149-396	1	MUD PUMP	INCLUDES REF NO. 45
2.	153-390	1	HOSE (24JFX-240FX-38"-1250)	
3.	149-646	1	CYLINDER MOUNT (32N-24J)	
4.	151-211	1	CYL (1.25" X .50" X 4.00")	
5.	149-1001	1	SHUT-OFF (32NF-32NF)	
	191-069	-	BALL VALVE REPAIR KIT	
6.	106-334	1	SCREW (M12-1.75 X 50MM)	
7.	106-685	1	LOCKNUT(M12-1.75, PRV TRQ, 10.9)	
8.	306-388	1	VALVE ARM	
9.	106-391	2	WASHER (M12)	
10.	105-512	1	COTTER PIN (3/32" Xf")	
11.	115-052	1	ELBOW (32N-32NF90)	
12.	515-680	2	NIPPLE (32N-2")	
13.	153-344	1	TEE (32NF-32NF-32NF)3000PSI	
14.	106-442	4	FLG LOCKNUT (M16-2.00, PRV TRQ)	
15.	115-064	1	REDUCER (32N-12NF)	
16.	159-088	1	QDC BODY (08-08SF)	
17.	155-706	1	O-RING (908 D90)	
18.	156-732	1	CONNECTOR (08J-080)	
19.	154-490	1	CONNECTOR (12N-08090)	
20.	114-017	1	STREET ELBOW (48N-48NF90)	
21.	514-386	1	FHC BODY (3-1/2" FHC X 3"NPT)	
22.	153-255	1	FHC PLUG (-56)	
23.	156-938	1	PLUG (32N)	
24.	106-018	1	JAM NUT (3/8-NF)	
25.	216-047	1	SPEED PICKUP	
26.	216-026	1	FLEX-GUARD (.250")	
27.	215-224	1	3-WAY WP MALE CONNECTOR	
28.	214-104	3	PACKARD MALE TERMINAL	
29.	157-645	3	WEATHER-PAC SEAL (2.80MM)	
30.	178-969	AR	SHIM (.062)	REFER TO SERVICE BULLETIN 052-596 FOR INSTALLATION
31.	178-970	AR	SHIM (.100)	REFER TO SERVICE BULLETIN 052-596 FOR INSTALLATION
32.	313-759	1	LANYARD	
33.	499-557	1	SIGHTGLASS	
34.	115-115	1	STREET ELBOW (08N-08NF90)	
35.	115-164	1	NIPPLE (08N-2")	
36.	514-106	1	CAP (08NF)	

NOT SHOWN:

FOOTNOTES:

NOTE:

1. REFER TO O-RING CHART (800-301) IN BACK OF THE BOOK FOR REPLACEMENT OF O-RINGS.

FLUID PUMP PLUMBING 70 GPM

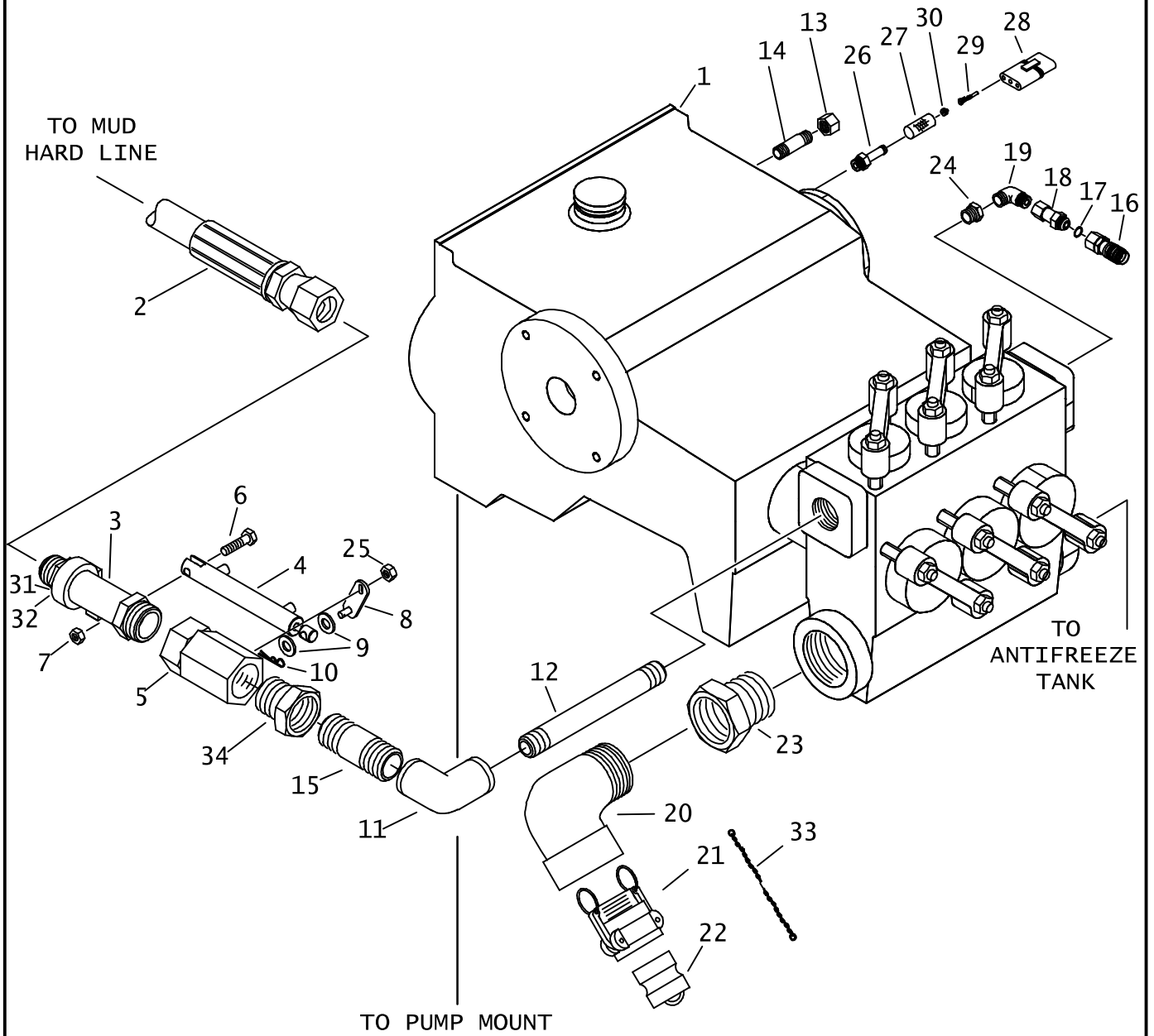

FLUID PUMP PLUMBING

70 GPM

REF NO.	PART NUMBER	QTY	DESCRIPTION	REMARKS
1.	158-434	1	FLUID PUMP	
2.	157-419	1	HOSE (24JFX-240FX-32"-1250)	
3.	149-646	1	CYLINDER MOUNT (32N-24J)	
4.	151-211	1	CYL (1.25" X .50" X 4.00")	
5.	149-076	1	SHUT-OFF (32NF-32NF)	
	191-069	-	BALL VALVE REPAIR KIT	
6.	106-334	1	SCREW (M12-1.75 X 50MM)	
7.	106-685	1	LOCKNUT(M12-1.75, PRV TRQ, 10.9)	
8.	306-388	1	VALVE ARM	
9.	106-391	2	WASHER (M12)	
10.	105-512	1	COTTER PIN (3/32" Xf")	
11.	515-679	1	ELBOW (20NF-20NF90)	
12.	157-418	1	NIPPLE (20N-8")	
13.	514-106	1	CAP (08NF)	
14.	115-161	1	NIPPLE (08N, 3-1/2")	
15.	115-207	1	NIPPLE (20N-2")	
16.	159-088	1	QDC BODY (08-08SF)	
17.	155-706	1	O-RING (908 D90)	
18.	156-732	1	CONNECTOR (08J-08O)	
19.	154-490	1	CONNECTOR (12N-08090)	
20.	114-004	1	STREET ELBOW (32N-32NF90)	
21.	159-485	1	FHC BODY (32-32N)	
22.	149-120	1	DUST PLUG (32 FHC)	
23.	114-024	1	REDUCER (40N-32NF)	
24.	155-208	1	REDUCER (20N-12NF)	
25.	106-018	1	JAM NUT (3/8-NF)	
26.	216-047	1	SPEED PICKUP	
27.	216-026	1	FLEX-GUARD (.250")	
28.	215-224	1	3-WAY WP MALE CONNECTOR	
29.	214-104	3	PACKARD MALE TERMINAL	
30.	157-645	3	WEATHER-PAC SEAL (2.80MM)	
31.	178-969	AR	SHIM (.062)	REFER TO SERVICE BULLETIN 052-596 FOR INSTALLATION
32.	178-970	AR	SHIM (.100)	REFER TO SERVICE BULLETIN 052-596 FOR INSTALLATION
33.	313-759	1	LANYARD	
34.	515-678	1	REDUCER (32N-20NF)	

NOT SHOWN:

FOOTNOTES:

NOTE:

1. REFER TO O-RING CHART (800-301) IN BACK OF THE BOOK FOR REPLACEMENT OF O-RINGS.

FLUID SYSTEM PLUMBING

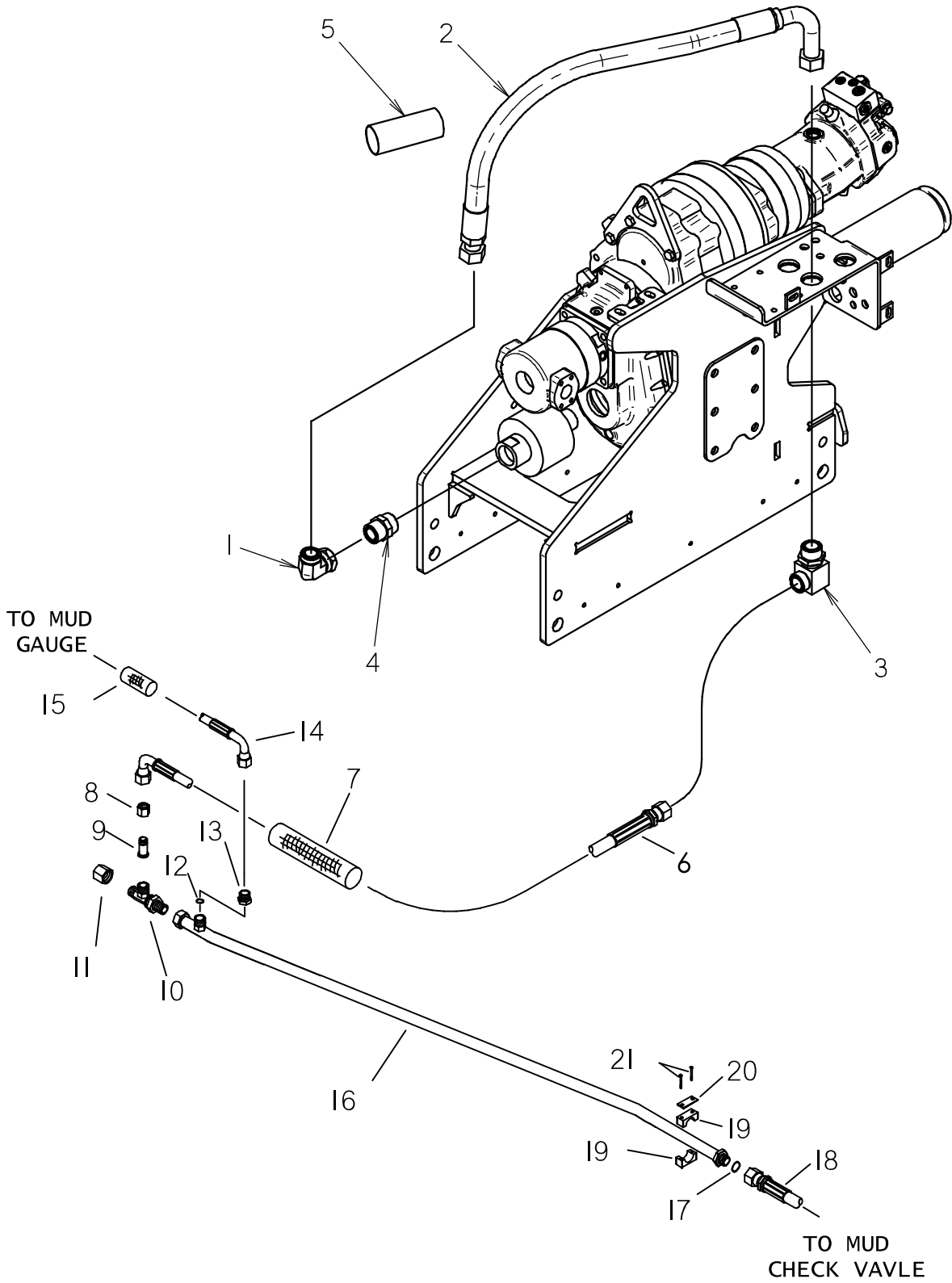

FLUID SYSTEM PLUMBING

REF NO.	PART NUMBER	QTY	DESCRIPTION	REMARKS
1	514-422	1	CONNECTOR (200-200FX90)	
2	150-1795	1	HOSE (200FX90L -43"-3000)	
3	153-679	1	SP CONNECTOR (200-20090BK)	
4	153-392	1	CONNECTOR (24N-200)	USE LOCTITE 567 OR EQUIVALENT
5	117-668	1	ABRASION SLEEVE(2.38" X 42")	
6	150-1708	1	HOSE (200FX90S-283"-3000)	
7	117-705	1	ABRASION SLEEVE (2.38" X 78")	
8	149-085	1	REDUCER STEM (200)	
9	149-086	1	REDUCER NUT (240F)	
10	514-413	1	BK RUN TEE (240-240-240BK)	
11	149-083	1	CAP (240F)	
12	157-038	1	O-RING (012 D90)	
13	154-373	1	REDUCER (040-060F)	
14	515-137	1	HOSE (040FX90-90"-3000)	
15	117-209	1	ABRASION SLEEVE (1.00" X 90")	
16	156-892	1	HYDRAULIC LINE (-24)	
17	157-130	1	O-RING (029 D90)	
18	153-390	1	HOSE (24JFX-240FX-38"-1250)	120 GPM
	157-419	1	HOSE (24JFX-240FX-32"-1250)	70 GPM
19	111-008	1	BOLT-ON CLAMP (1-1/2", SET)	
20	322-362	1	BACKUP SPACER	
21	105-224	2	BOLT (1/4-NC X 2-1/2")	

NOT SHOWN:

FOOTNOTES:

NOTE:

REFER TO O-RING CHART (800-301) IN BACK OF THE BOOK FOR REPLACEMENT OF O-RINGS.

FLUID PUMP (FLUID END)

120 GPM

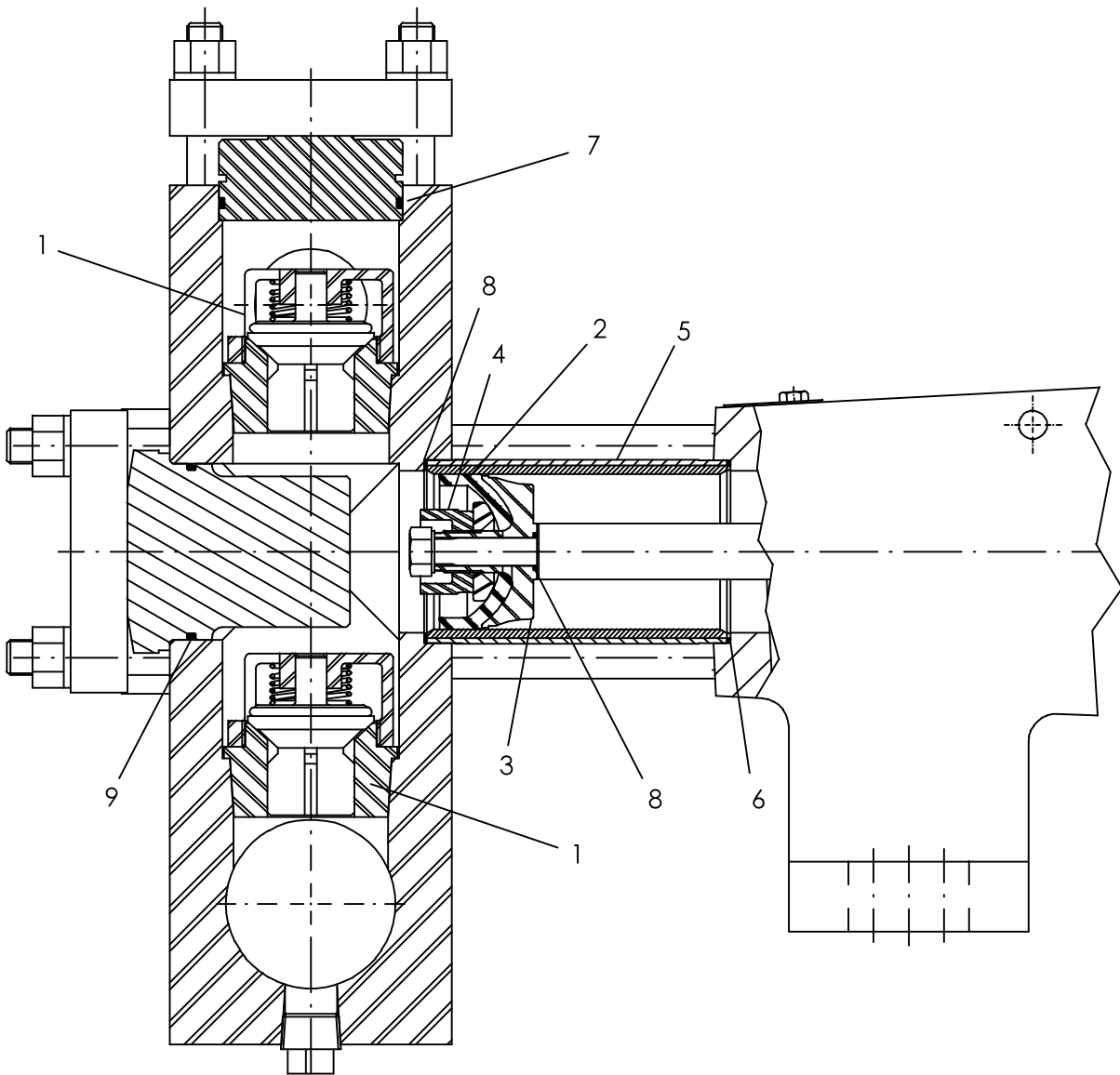

FLUID PUMP (FLUID END) 120 GPM

REF NO.	PART NUMBER	QTY	DESCRIPTION	REMARKS
1.	191-054	1	VALVE REPAIR KIT	INCLUDES PARTS FOR ALL VALVES IN PUMP. SEE FOOTNOTE 1.
2.	191-1008	1	PACKING REPAIR KIT	
3.	499-041	3	CUP HOLDER	
4.	499-039	3	PLUNGER NUT	
5.	499-089	3	CYL (2.750")	
6.	499-042	3	CYLINDER GASKET	
7.	157-191	3	O-RING (233 D90)	
8.	157-202	3	O-RING (042 D70)	
9.	157-031	3	O-RING (234 D90)	

NOT SHOWN:

FOOTNOTES:

KIT INCLUDES ALL PARTS, O-RINGS, GASKETS AND PLUNGER NUTS TO REBUILD ALL CYLINDERS.

NOTE:

FLUID PUMP (FLUID END)

70 GPM

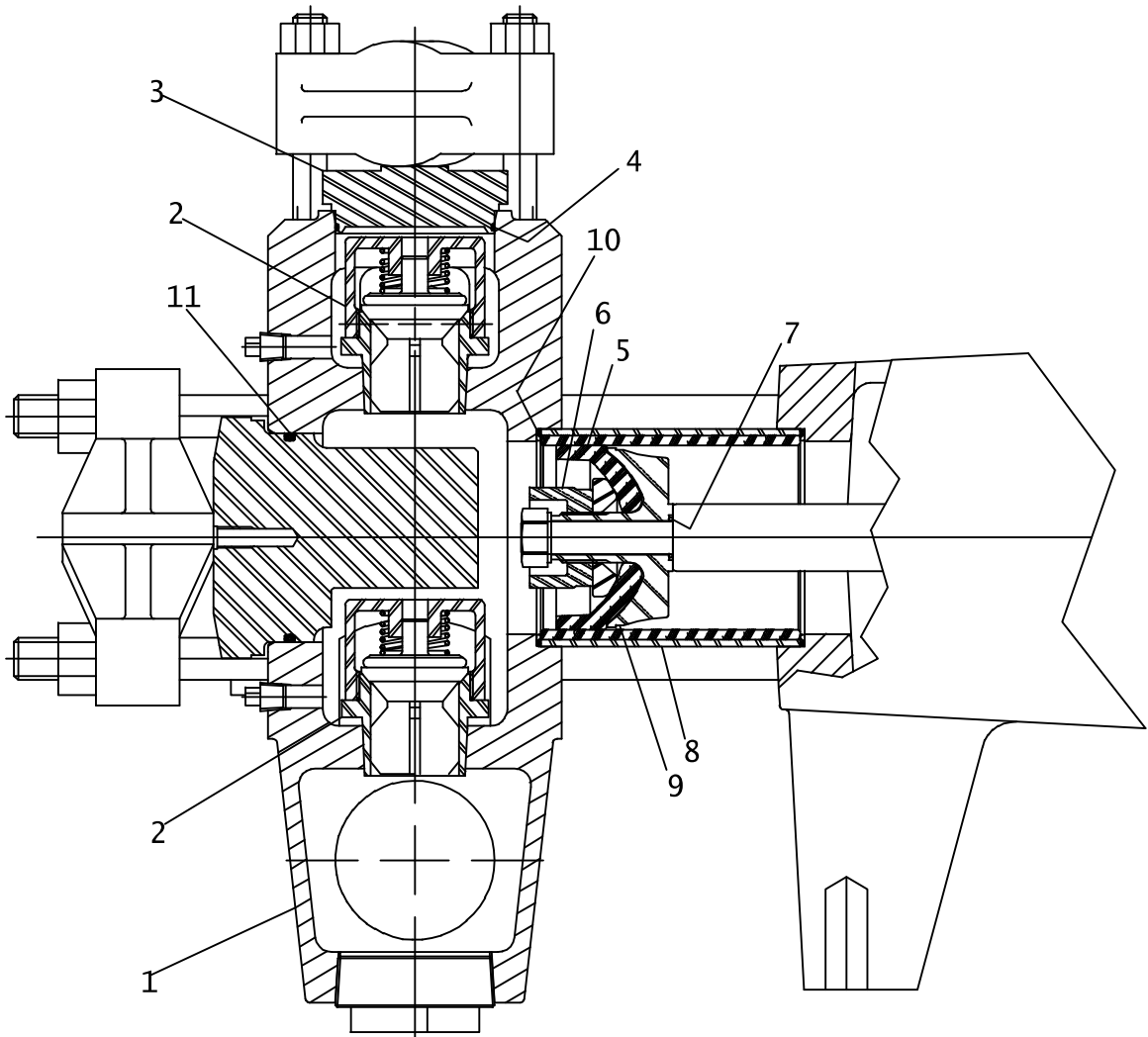

FLUID PUMP (FLUID END) 70 GPM

REF NO.	PART NUMBER	QTY	DESCRIPTION	REMARKS
	158-434		FLUID PUMP	INCL REF NO'S 1 - 11
	197-062		REBUILT 158-434 MUD PUMP	INCL REF NO'S 1 - 11
	158-017		MUD PUMP	
	190-783		L1122 A/R VALVE SERVICE KIT	INCL REF NO'S 2, 4 & 11
1.	499-035	1	FLUID CYLINDER	
2.	499-036	6	VALVE	
3.	499-037	3	VALVE COVER	
4.	157-190	3	O-RING (139 D90)	
5.	191-1008	1	PACKING REPAIR KIT	SEE FOOTNOTE 1
6.	499-039	3	PLUNGER NUT	
7.	155-778	3	O-RING (014 D70, VITON)	
8.	499-040	3	CYLINDER (2-3/4")	
9.	499-041	3	CUP HOLDER	
10.	499-042	6	CYLINDER GASKET	
11.	157-191	3	O-RING (233 D90)	

NOT SHOWN:

FOOTNOTES:

KIT INCLUDES ALL PARTS, O-RINGS, GASKETS AND PLUNGER NUTS TO REBUILD ALL CYLINDERS

NOTE:

FLUID PUMP (POWER END)

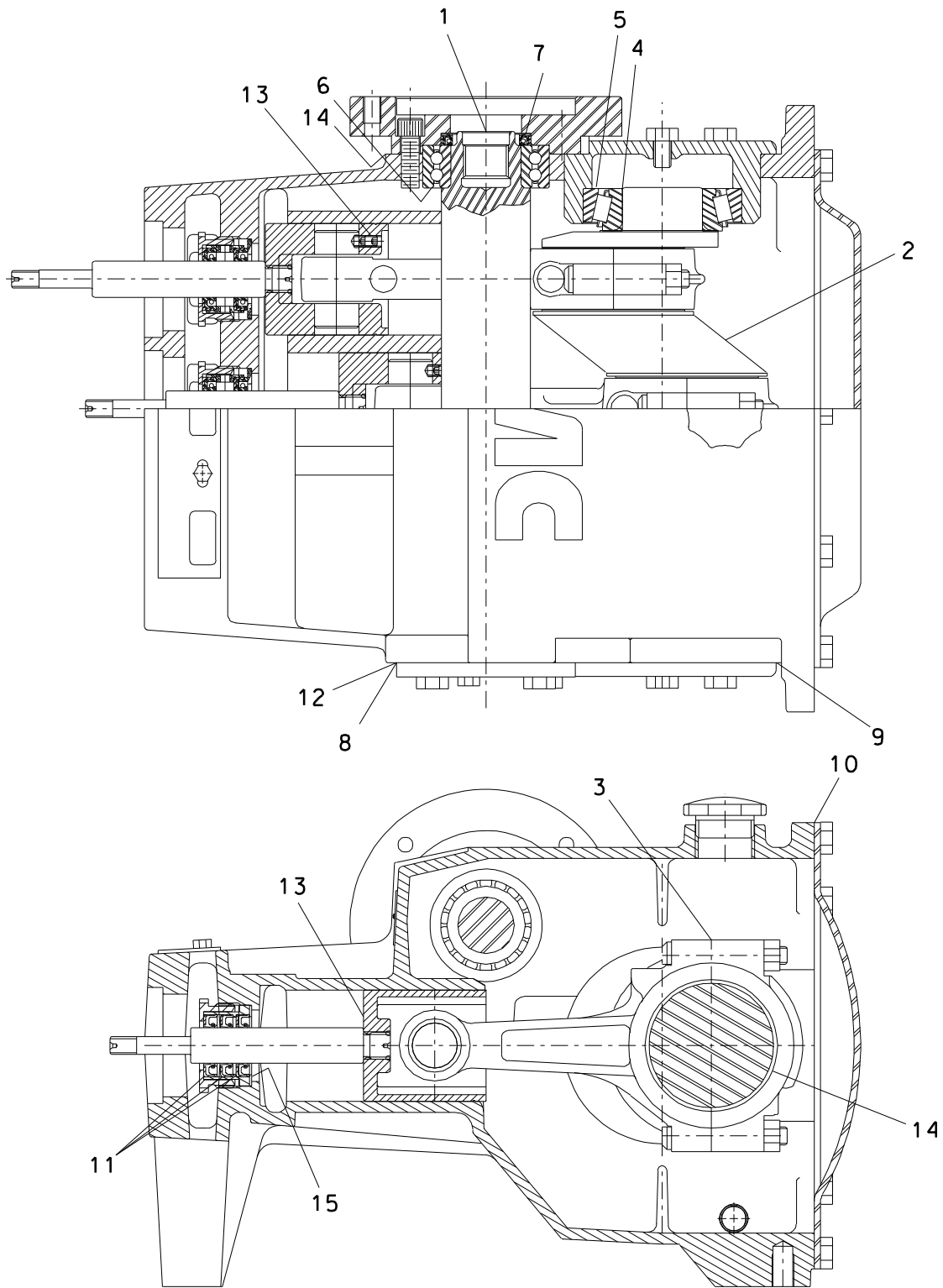

FLUID PUMP (POWER END)

REF NO.	PART NUMBER	QTY	DESCRIPTION	REMARKS
	158-434		FLUID PUMP	INCL REF NO'S 1 - 15
	197-062		REBUILT 158-434 FLUID PUMP	
	158-017		FLUID PUMP	INCL REF NO'S 1 - 15
1.	499-075	1	PINION SHAFT	
2.	499-076	1	ECCENTRIC GEAR	
3.	499-077	3	CONNECTING ROD	
4.	126-192	2	TAPERED BEARING (2.250")	
5.	126-193	2	TAPERED RACE (4.437")	
6.	125-144	2	BALL BEARING (1.968")	
7.	157-738	1	OIL SEAL, PINION SHAFT	
8.	165-884	2	GASKET, PINION CAP	
9.	165-885	2	GASKET, BEARING CAP	
10.	165-886	1	GASKET, BACKCOVER	
11.	157-739		INTERNAL SEAL (.")	
12.	165-887	6	SHIM	
13.	499-078	3	CROSSHEAD	
14.	126-194	6	ROD BEARING (PAIR)	
15.	165-888	3	SEAL HOLDER - GASKET	

FOOTNOTES

FLUID PUMP (POWER END) L1122, L1622

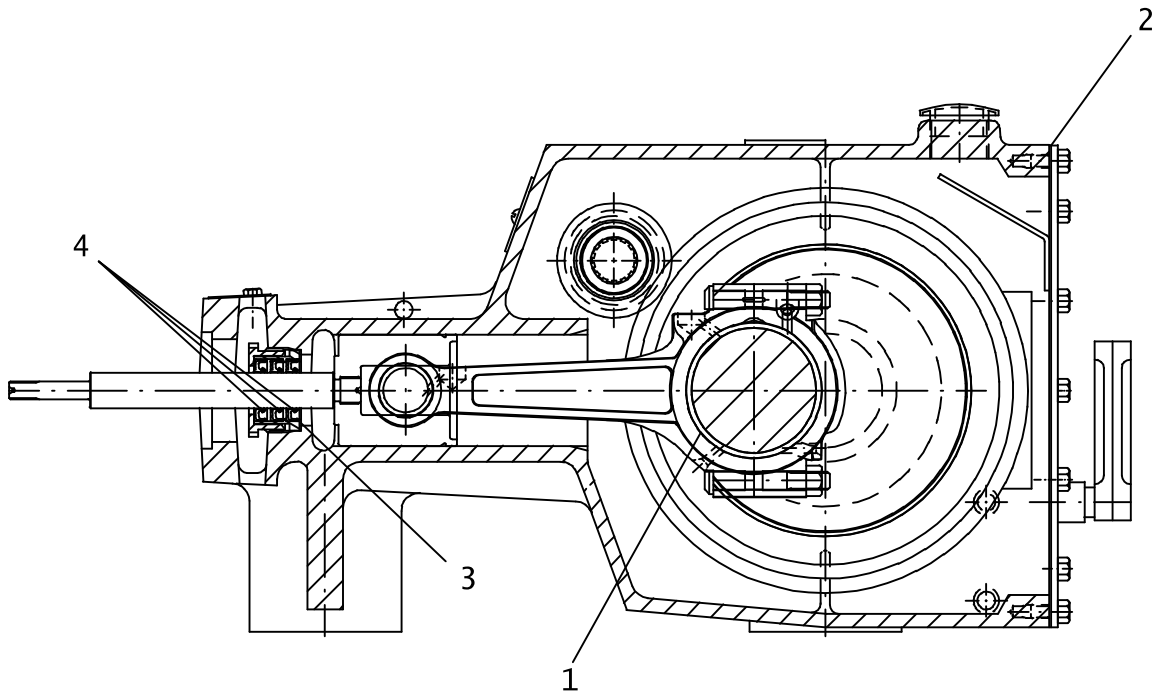
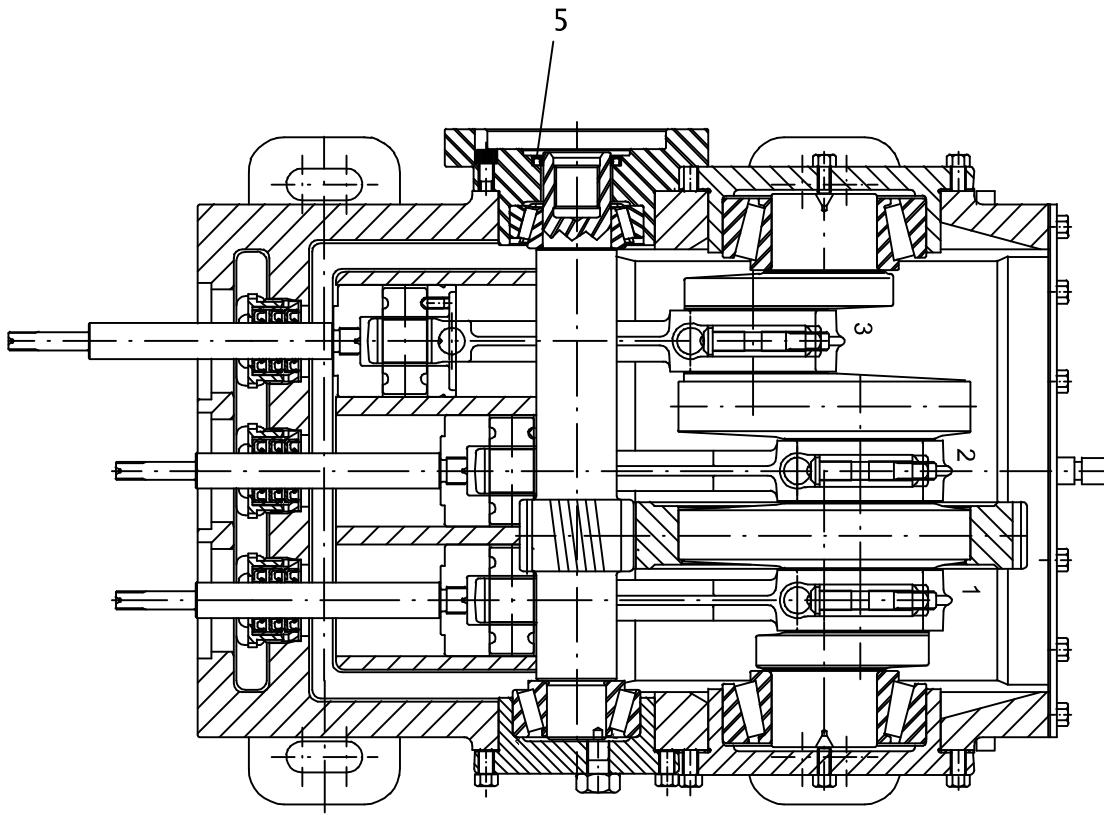

FLUID PUMP (POWER END)

L1122, L1622

REF NO.	PART NUMBER	QTY	DESCRIPTION	REMARKS
1.	126-194	3	ROD BEARING (PAIR)	CONNECTING ROD USE 3 PAIR PER PUMP
2.	165-896	1	BACK COVER GASKET	
3.	165-888	3	SEAL HOLDER GASKET	
4.	157-739	9	INTERNAL SEAL	PLUNGER ROD
5.	157-742	1	INTERNAL SEAL	ADAPTER

NOT SHOWN:

FOOTNOTES:

NOTE:

PUMP MOUNT

70GPM & 120GPM FLUID PUMPS

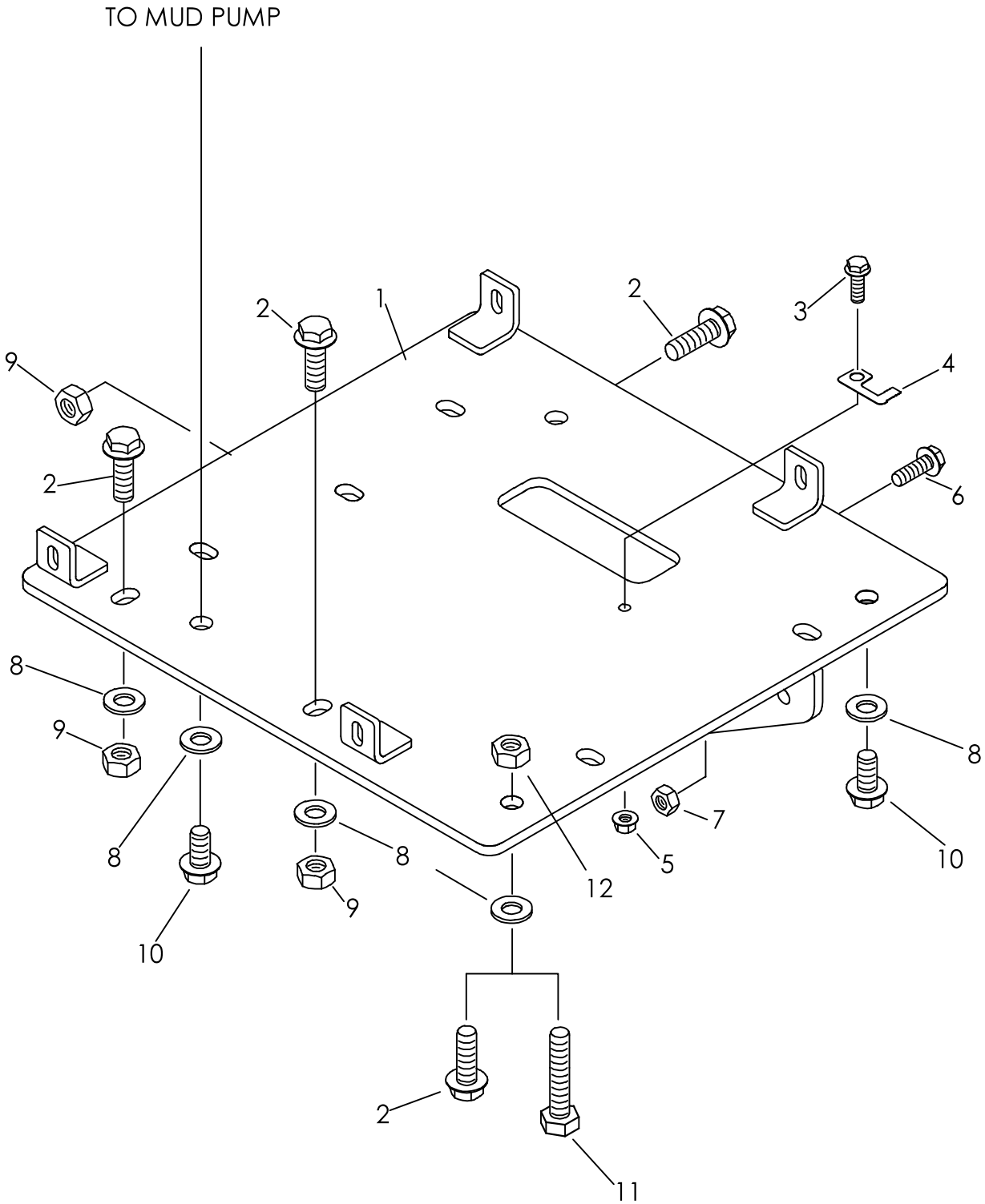

PUMP MOUNT

70GPM & 120GPM FLUID PUMPS

REF NO.	PART NUMBER	QTY	DESCRIPTION	REMARKS
1.	319-544	1	PUMP MOUNT	USED WITH 70 GPM & 120 GPM PUMPS
2.	106-470	AR	FLG SCREW (M16-2.00 X 40MM)	USE 4 W/70 GPM & 3 W/120 GPM PUMPS
3.	106-381	1	FLG LK SCREW (M8-1.25 X 25MM)	USED WITH 70 GPM & 120 GPM PUMPS
4.	211-041	1	CONNECTOR CLIP	USED WITH 70 GPM & 120 GPM PUMPS
5.	106-386	1	FLG LOCKNUT (M8-1.25)	USED WITH 70 GPM & 120 GPM PUMPS
6.	106-632	1	FLG LK SCR (M12-1.75X35MM,SER)	USED WITH 70 GPM & 120 GPM PUMPS
7.	106-685	1	LOCKNUT(M12-1.75,PRV TRQ,10.9)	USED WITH 70 GPM & 120 GPM PUMPS
8.	106-398	8	WASHER (M16, HARDENED)	USED WITH 70 GPM PUMP
	105-398	6	WASHER (1/2")	USED WITH 120 GPM PUMP
9.	106-545	3	LOCKNUT (M16-2.0,PRV TRQ,10.9)	USED WITH 70 GPM & 120 GPM PUMPS
10.	105-400	5	BOLT (5/8-NC X 1-1/4")	USED WITH 70 GPM PUMP
	106-341	3	SCREW (M16-2.0 X 70MM)	USED WITH 120 GPM PUMP
11.	108-100	1	SCREW (M16-2 X 80MM, 10.9)	USED WITH 120 GPM PUMP
12.	106-545	1	LOCKNUT (M16-2.0,PRV TRQ,10.9)	USED WITH 70 GPM PUMP

NOT SHOWN:

FOOTNOTES:

NOTE:

ANTIFREEZE TANK

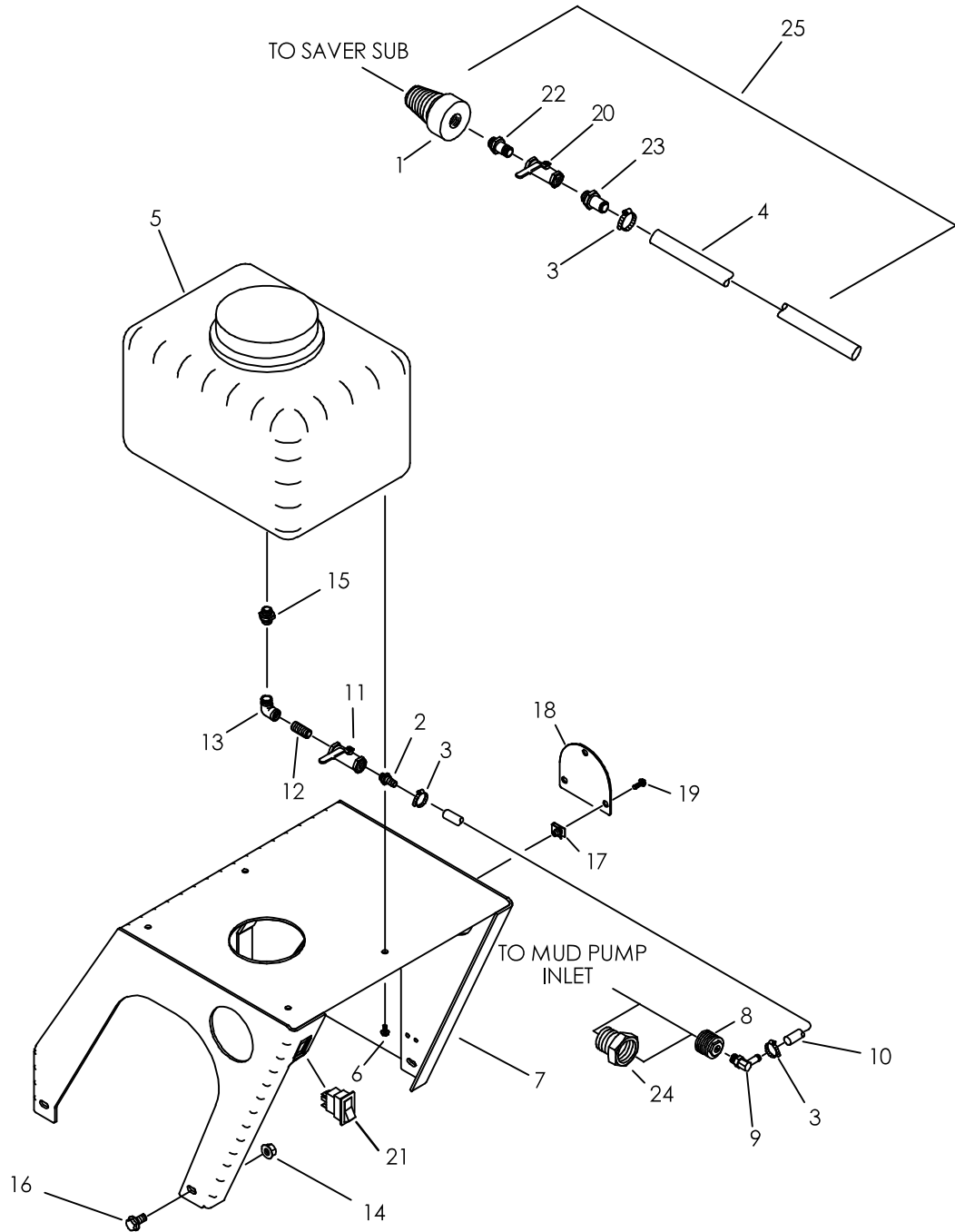

ANTIFREEZE TANK

REF NO.	PART NUMBER	QTY	DESCRIPTION	REMARKS
1.	211-097	1	ADAPTER	USE WITH AT PIPE IOD = 4.125" USE WITH JTMI PIPE IOD = 3.50"
	194-244	1	ADAPTER	
2.	155-136	1	S/O COUPLER (16N-16H)	
3.	110-353	3	WORM CLAMP (3/4" TO 1-1/2")	
4.	116-897	AR	BULK TUBING (1", SOLD PER 1')	USE I @ 72"
5.	364-515	1	WATER TANK (8 GAL)	
	190-053	-	POLY-PATCH TANK REPAIR KIT	
	110-707		TANK CAP (96NF)	
6.	105-836	4	FLG LOCK BOLT (1/4-NC X 1/2")	
7.	319-546	1	TANK MOUNT	
8.	115-085	1	REDUCER (32N-16NF)	SEE FOOTNOTE 1
	153-335	1	REDUCER BUSHING (48N-16NF)	SEE FOOTNOTE 2
9.	155-137	1	S/O COUPLER(16N-16H90)	
10.	116-460	AR	BULK HOSE (1", SOLD PER 1')	USE I @ 20" FOR 70 GPM PUMP
	116-460	AR	BULK HOSE (1", SOLD PER 1')	USE I @ 22" FOR 70 GPM PUMP
11.	514-318	1	SHUT-OFF (16NF-16NF)	ROTATE HANDLE TO SIDE, POINTED DOWN.
12.	114-011	1	ALL THREAD (16N)	
13.	115-440	1	STREET ELBOW (16N-16NF90)	
14.	106-387	4	FLG LOCKNUT (M10-1.50)	
15.	514-400	1	BK CONN (16NF-16NFBK, NYL)	
16.	106-164	4	FLG LK SCREW (M10-1.50 X 30MM)	
17.	106-551	3	CLIP NUT (M8-1.25)	
18.	310-694	1	COVER	
19.	106-991	3	FLG LK SCREW (M8-1.25 X 20MM)	
20.	120-074	1	SHUT-OFF VALVE (16S-16S)	
21.	217-907	1	ROCKER SWITCH (DPDT) ON-ON	
22.	514-121	1	CONNECTOR (16N-16S)	
23.	514-088	1	S/O COUPLER (16S-16H)	
24.	114-024	1	REDUCER (40N-32NF)	SEE FOOTNOTE 1
25.	101-134	1	ANTI-FREEZE RECLAIMER	USE W/ AT PIPE; INCLUDES REF. #'S 1, 3, 4, 20, 22, 23
	101-137	1	ANTI-FREEZE RECLAIMER	USE W/ JT PIPE; INCLUDES REF. #'S 1, 3, 4, 20, 22, 23

NOT SHOWN:

153-255 FHC PLUG (I-56) USE TO PLUG FHC FEMALE INLET ON MUD PUMP.

FOOTNOTES:

1. USED WITH I58-434 (70 GPM MUD PUMP)
2. USED WITH I49-396 (120 GPM MUD PUMP)

NOTE:

REFER TO O-RING CHART (800-30I) IN BACK OF THE BOOK FOR REPLACEMENT OF O-RINGS.

WASH WAND

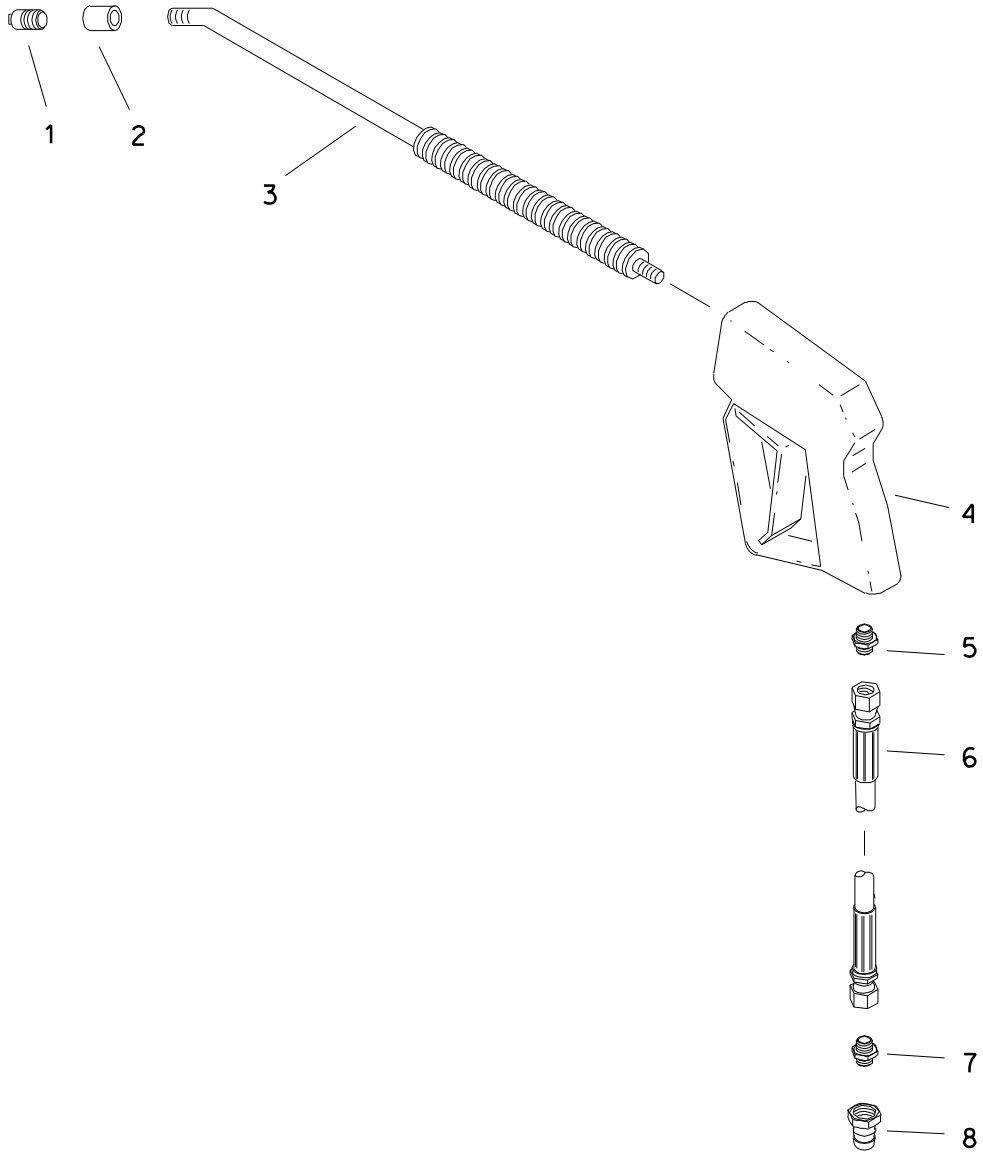

WASH WAND

REF NO.	PART NUMBER	QTY	DESCRIPTION	REMARKS
1.	155-242	1	NOZZLE (04N, ORF .047", TC)	
2.	115-170	1	COLLAR (04NF)	
3.	259-353	1	WASH WAND (04N-36")	
4.	259-197	1	SPRAY GUN	
	190-179		SEAL REPAIR KIT	RHINO INDUSTRIES (190-938 CHAPPELL SUPPLY)
5.	514-141	1	CONNECTOR (06N-080)	
6.	154-753	1	HOSE (08OFX-600"-3000)	
7.	154-233	1	CONNECTOR (08S-080)	
8.	159-089	1	QDC ADAPTER (08-08SF)	
	190-186		SEAL REPAIR KIT	

FOOTNOTES

NOTE
REFER TO O-RING CHART (800-301) IN BACK OF THE BOOK FOR REPLACEMENT OF O-RINGS.

NOTES:

HYDRAULICS

OIL COOLER HYDRAULICS

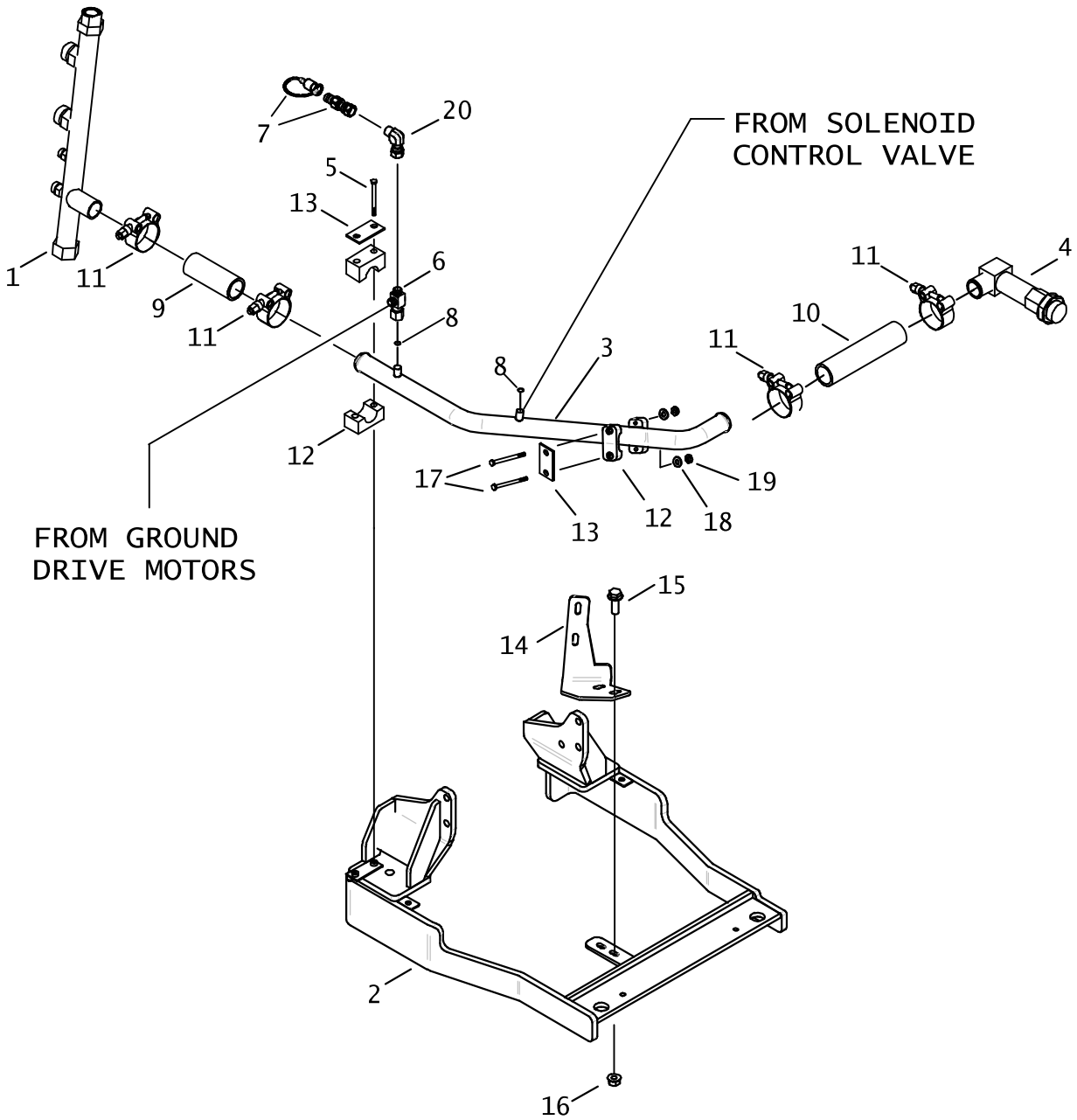

OIL COOLER HYDRAULICS

REF NO.	PART NUMBER	QTY	DESCRIPTION	REMARKS
1.	153-389	-	COOLER BY-PASS	
2.	327-383	-	FRONT ENGINE MOUNT	
3.	150-1334	-	COOLER SUPPLY TUBE	
4.	150-1277	1	SPECIAL ELBOW (20S-24H, XL)	
5.	105-224	2	BOLT (1/4-NC X 2-1/2")	
6.	154-265	1	UNION RUN TEE (040FX-040-040)	
7.	159-156	1	QDC ADAPTER (02-040F)	
8.	157-037	2	O-RING (011 D90)	
9.	117-897	1	BULK HOSE (1-1/2", SOLD PER 1")	USE 1 @ 4.75"
10.	117-897	1	BULK HOSE (1-1/2", SOLD PER 1")	USE 1 @ 8.0"
11.	318-890	4	T-BLT CLP BRIDG 1.875 - 2.188	
12.	111-008	2	BOLT-ON CLAMP (1-1/2", SET)	
13.	322-362	2	BACKUP SPACER	
14.	300-2573	1	HARDLINE MOUNT BRACKET	
15.	106-724	2	FLG SCREW (M10-1.50 X 25mm)	
16.	106-387	2	FLG LOCKNUT (M10-1.50)	
17.	107-283	2	BOLT (1/4-NC X 3")	
18.	106-076	2	WASHER (1/4")	
19.	105-085	2	LOCKNUT (1/4 NC)	
20.	154-255	1	UNION (040-040FX90)	

NOT SHOWN:

FOOTNOTES:

NOTE:

OIL COOLER RETURN HYDRAULICS

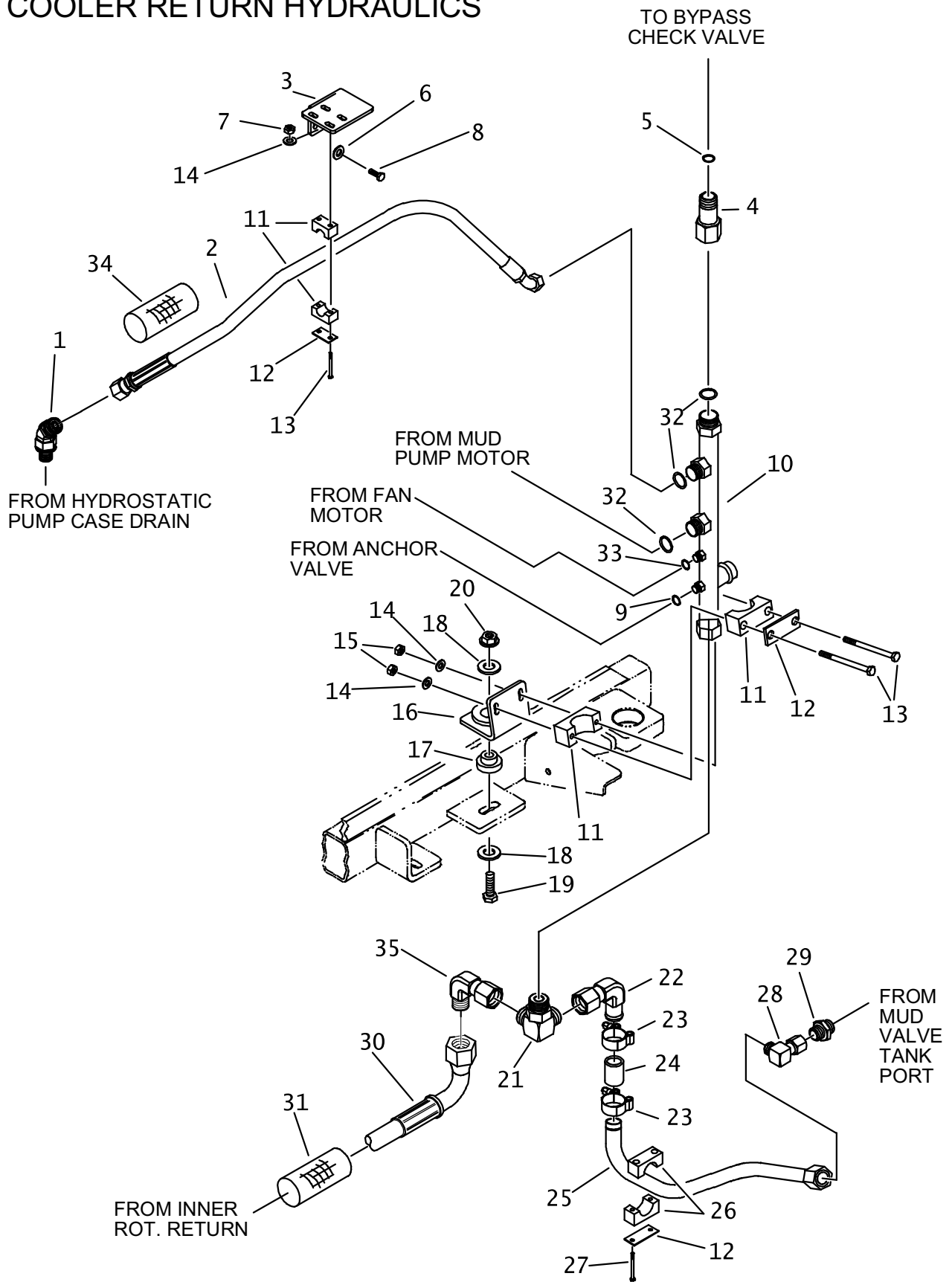

OIL COOLER RETURN HYDRAULICS

REF NO.	PART NUMBER	QTY	DESCRIPTION	REMARKS
1.	154-371	1	CONNECTOR (12S-16045)	
2.	159-756	1	HOSE (160FX45-38"-200)	CASE DRAIN
3.	354-464	1	TOP REAR COOLANT BRACKET	
4.	510-014	1	UNION (16J-160FX)	
5.	155-748	1	O-RING (916 D90)	
6.	106-396	2	WASHER (M10, HARDENED)	
7.	105-085	2	LOCKNUT (1/4-NC)	
8.	105-245	2	SCREW (M10-1.50 X 25MM)	
9.	157-040	1	O-RING (014 D90)	
10.	153-389	1	COOLER BY-PASS	
11.	111-008	2	BOLT-ON CLAMP (1-1/2", SET)	
12.	322-362	3	BACKUP SPACER	
13.	107-283	4	BOLT (1/4-NC X 3")	
14.	106-076	4	WASHER (1/4")	
15.	105-085	3	LOCKNUT (1/4-NC)	
16.	318-387	1	MOUNT	
17.	116-498	1	SHOCK MOUNT	
18.	105-884	2	WASHER (.531")	
19.	105-229	1	BOLT (1/2-NC X 2")	
20.	105-833	1	FLG LOCKNUT (1/2-NC)	
21.	157-261	1	SPECIAL TEE (16S-200-200)	
22.	157-260	1	ELBOW (20H-200FX90, SPECIAL)	
23.	111-028	2	T-BOLT CLAMP (1.75"-2.00")	
24.	117-896	1	BULK HOSE (1-1/4", SOLD PER 1")	USE 1 @ 8.50"
25.	157-251	1	HYD LINE (20)	VALVE DRAIN
26.	110-852	1	BLT-ON CLP(1.25", SOLD PER SET)	
27.	105-224	2	BOLT (1/4-NC X 2-1/2")	
28.	514-422	1	CONNECTOR (200-200FX90)	
29.	514-094	1	CONNECTOR (16S-200)	
30.	153-751	1	HOSE (200FX90S-88"-3000)	SEE FOOTNOTE 1, AT ONLY
	514-177	-	CAP (200F)	JT ONLY
31.	117-567	1	ABRASION SLEEVE (2.38" X 86")	
32.	155-714	3	O-RING (021 D90)	
33.	157-039	1	O-RING (014 D90)	
34.	117-654	1	ABRASION SLEEVE (1.75" X 38")	
35.	514-422	1	CONNECTOR (200-200FX90)	SEE FOOTNOTE 1, AT ONLY

NOT SHOWN:

FOOTNOTES:

- HOSE AND ELBOW REPLACED BY 514-177 CAP FOR JT MACH 1

NOTE:

REFER TO O-RING CHART (800-301) IN BACK OF THE BOOK FOR REPLACEMENT OF O-RINGS.

OIL RETURN HYDRAULICS

BEGINS WITH S/N CMWJ40T3KB0000125, CMWA40T3EB0000118

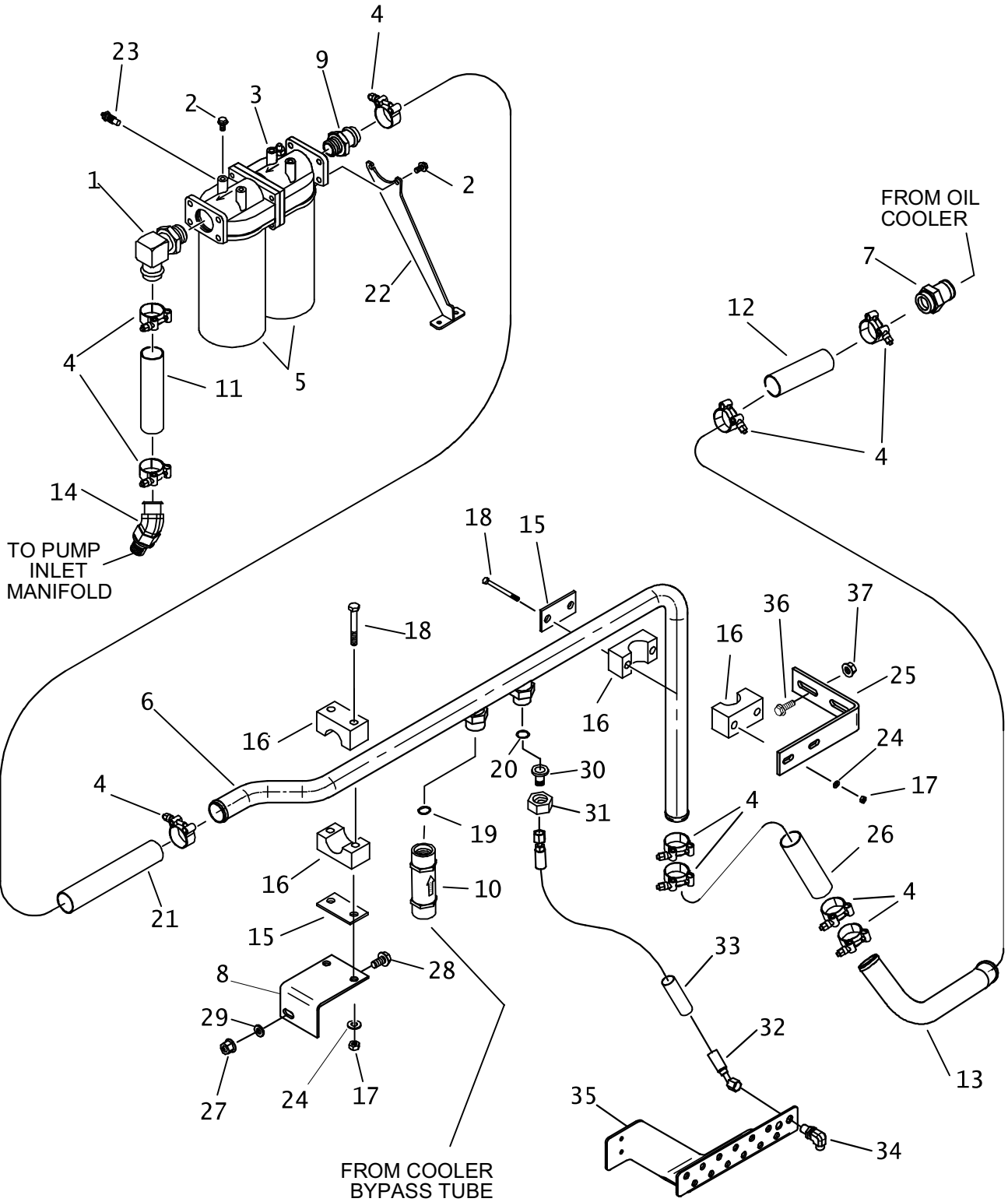

OIL RETURN HYDRAULICS

BEGINS WITH S/N CMWJ40T3KB0000125, CMWA40T3EB0000118

REF NO.	PART NUMBER	QTY	DESCRIPTION	REMARKS
1.	514-135	1	S/O COUPLER (24S-24H90)	
2.	105-825	6	FLG LK BOLT (3/8-NC Xf")	
3.	157-766	1	FILTER HEAD (20SF-20SF)	
4.	318-890	10	T-BLT CLP BRIDG 1.875 - 2.188	
5.	157-486	2	FILTER ELEMENT (10 MICRON)	
6.	152-199	1	COOLER RETURN TUBE	
7.	155-148	1	S/O COUPLER (20S-24H)	COOLER RETURN
8.	300-2429	1	BRACKET	
9.	514-138	1	S/O COUPLER (24S-24H)	
10.	153-436	1	FLOW CHECK (16SF-16SF)	FLOW ARROW ON CHECK VALVE MUST POINT UPWARD
11.	117-897	AR	BULK HOSE (1-1/2",SOLD PER 1")	USE 1 @ 10.25"
12.	117-897	AR	BULK HOSE (1-1/2", SOLD PER 1')	USE 2 @ 5.50"
13.	150-1246	1	TUBE, OIL COOLER INLET	
14.	153-370	1	S/O COUPLER (24S-24H45)	
15.	322-362	2	BACKUP SPACER	
16.	111-008	2	BOLT-ON CLAMP (1-1/2", SET)	
17.	105-085	4	LOCKNUT (1/4-NC)	
18.	107-283	4	BOLT (1/4-NC X 3")	
19.	155-748	1	O-RING (916 D90)	
20.	157-017	1	O-RING (018 D90)	
21.	117-897	AR	BULK HOSE (1-1/2",SOLD PER 1")	USE 1 @ 15.5"
22.	318-481	1	SUPPORT	
23.	217-765	1	INDICATOR SWITCH	
24.	106-076	4	WASHER (1/4")	
25.	300-2533	1	BAR	
26.	117-897	AR	BULK HOSE (1-1/2" , SOLD PER 1")	USE 1 @ 9"
27.	105-894	1	LOCKNUT (M10-1.50)	
28.	106-724	1	FLG LK SCREW (M10-1.50X 25mm)	
29.	106-396	1	WASHER (M10, HARDENED)	
30.	154-459	1	REDUCER STEM (060)	
31.	154-271	1	REDUCER NUT (120F)	
32.	154-969	1	HOSE (060FX45-58"-3000)	
33.	117-690	1	ABRASION SLEEVE (1.25"X 58")	
34.	154-229	1	BK CONNECTOR (060-06090 BK)	
35.	354-466	1	BULKHEAD PLATE	
36.	105-825	2	FLG LK BOLT (3/8-NC X 3/4)	
37.	105-834	2	FLG LOCKNUT (3/8-NC)	

NOT SHOWN:

FOOTNOTES:

NOTE:

REFER TO O-RING CHART (800-301) IN BACK OF THE BOOK FOR REPLACEMENT OF O-RINGS.

HYDRAULIC RESERVOIR

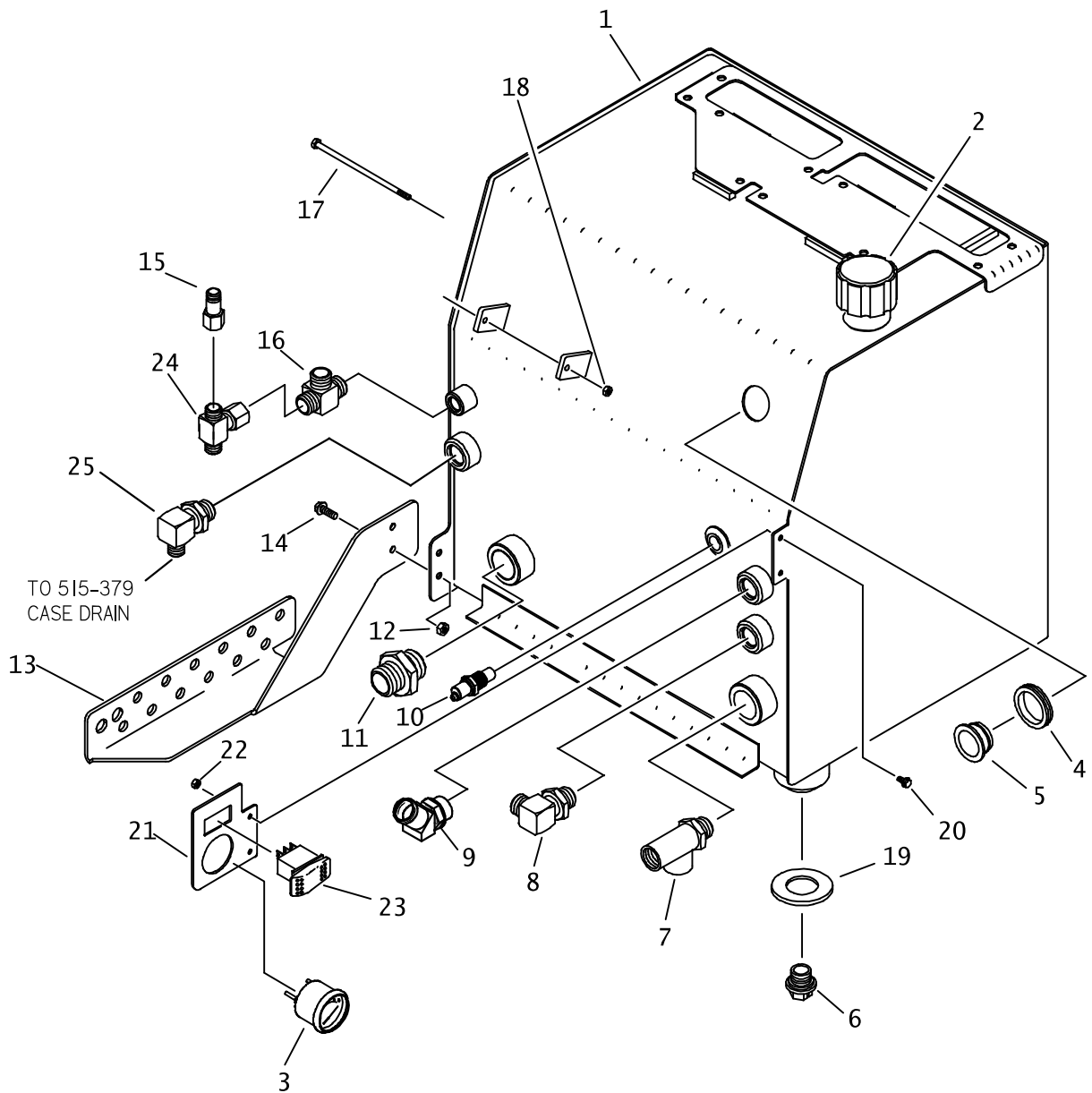

HYDRAULIC RESERVOIR

REF NO.	PART NUMBER	QTY	DESCRIPTION	REMARKS
1.	350-614	1	HYDRAULIC RESERVOIR	
2.	110-008	1	FILLER BREATHER	USE PERMATEx AVIATION GASKET SEALER
3.	215-128	-	HOURLY METER	AT ONLY
4.	115-320	1	GROMMET (1-1/2")	
5.	116-218	1	SIGHT GLASS (2")	
6.	149-398	1	DRAIN PLUG (1-UNF, .375 ORF)	
7.	153-899	1	RUN TEE (20S-16SF-16SF)	
8.	154-377	1	CONNECTOR (12S-16090)	
9.	115-281	1	CONNECTOR (16S-20H45)	
10.	214-819	1	TEMPERATURE SWITCH	USE 567 LOCTITE
11.	155-148	1	S/O COUPLER (20S-24H)	
12.	106-561	2	LOCKNUT (M8-1.25, PRV TRQ, 10.9)	
13.	354-466	1	BULKHEAD PLATE	
14.	106-162	2	FLG SCREW (M8-1.25 X 20MM)	
15.	154-262	-	REDUCER (060-080F)	
16.	154-299	-	RUN TEE (08S-080-080)	
17.	106-061	1	BOLT (1/4-NC X 6-1/2")	
18.	105-085	1	LOCKNUT (1/4-NC)	
19.	149-829	1	1" SEAL WASHER	
20.	106-986	2	FLG LK SCREW (M6-1.00 X 12MM)	AT ONLY
21.	313-873	1	GAUGE PANEL	AT ONLY
22.	106-106	2	NUT (M6-1.00)	AT ONLY
23.	217-912	-	ROCKER SWITCH (DPDT) ON-ON-ON	AT ONLY
24.	154-257	1	UN BR TEE (080FX-080-080)	
25.	154-236	1	CONNECTOR (080-12S90)	SEE FOOTNOTE 1

FOOTNOTES:

USE ON 4020 WITH RACK AND PINION.

NOTE:

REFER TO O-RING CHART (800-301) IN BACK OF THE BOOK FOR REPLACEMENT OF O-RINGS.

ROTATION, THRUST AND MUD GAUGES

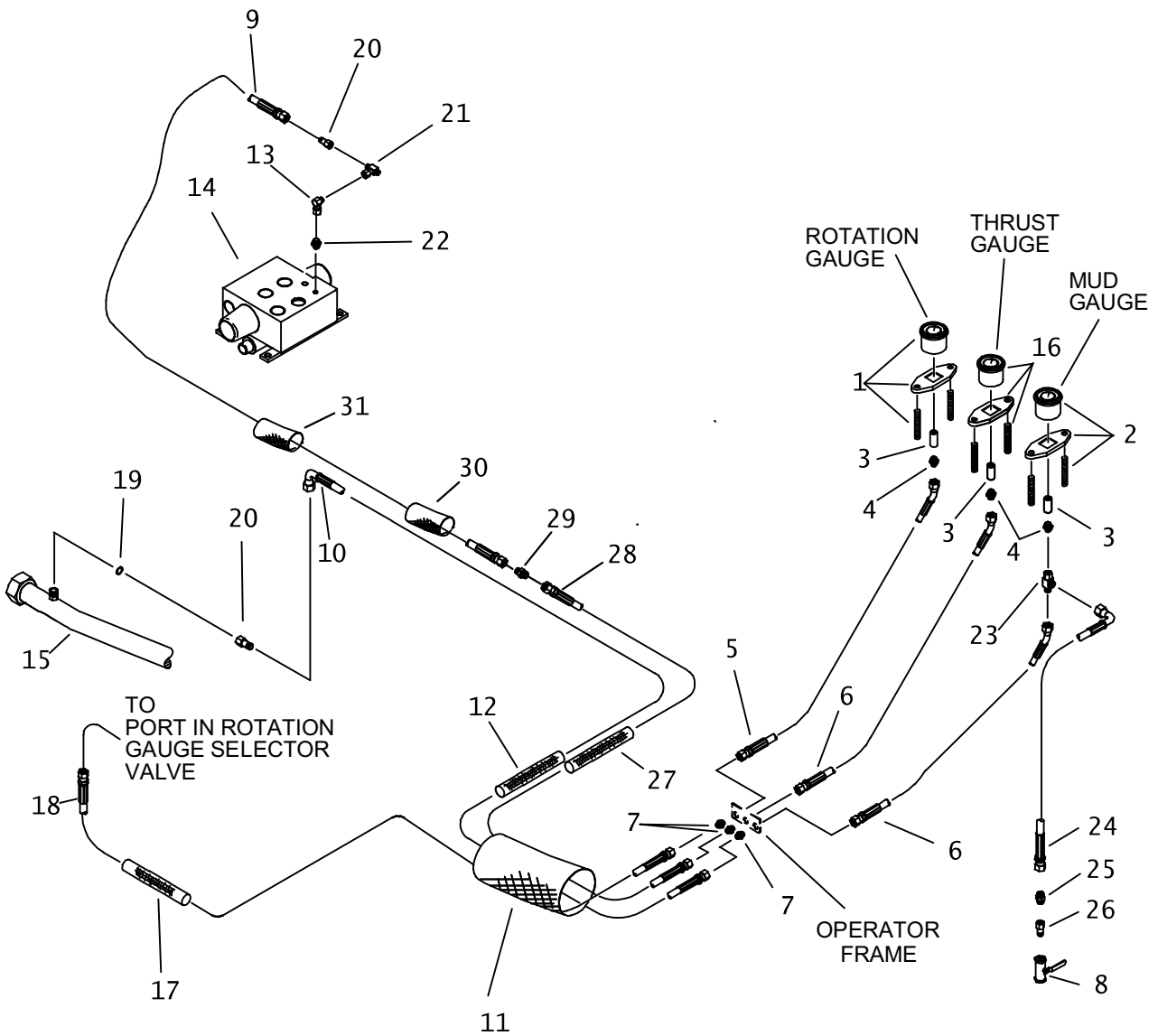

ROTATION, THRUST AND MUD GAUGES

REF NO.	PART NUMBER	QTY	DESCRIPTION	REMARKS
1.	258-061	1	HYD PRESSURE GAUGE (6000 PSI)	
2.	150-1964	1	PRESSURE GAUGE (2000PSI)	
3.	514-408	3	COLLAR (04NF)	
4.	154-339	3	CONNECTOR (04N-040)	
5.	515-646	1	HOSE (040FX45-62"-10000)	
6.	515-283	2	HOSE (040FX45-62"-3000)	
7.	154-275	3	BK CONNECTOR (040-040BK)	
8.	120-071	1	SHUT-OFF (04NF-04NF)	
9.	515-161	1	HOSE (040FX-160"-3000)	
	150-1980	1	HOSE (040FX-282"-3000)	USE ON 4020 WITH RACK AND PINION. SEE FOOTNOTE 4
10.	515-137	1	HOSE (040FX90-90"-3000)	
11.	117-283	1	ABRASION SLEEVE (4.000" X 20")	
12.	117-209	1	ABRASION SLEEVE (1.00" X 90")	
13.	154-228	-	UNION (060-060FX90)	
14.	157-440	-	THRUST VALVE (ELECTRIC)	SEE FOOTNOTE 2
	150-1458	-	THRUST VALVE (ELECTRIC)	SEE FOOTNOTE 3
	500-1290	-	THRUST VALVE COIL	
15.	156-892	-	HYDRAULIC LINE (-24)	
16.	258-063	1	GAUGE (4000 PSI)	
17.	117-792	1	ABRASION SLEEVE (1.00" X 115")	
18.	153-730	1	HOSE (040FX-116"-6000)	SEE FOOTNOTE 1
19.	157-038	1	O-RING (012 D90)	
20.	154-373	2	REDUCER (040-060F)	
21.	154-348	-	UNION BRANCH TEE (060FX-060-060)	
22.	154-411	-	CONNECTOR (04S-060)	
23.	154-265	1	UNION RUN TEE (040FX-040-040)	
24.	515-179	1	HOSE (040FX90-11"-3000)	
25.	153-238	1	BK CONNECTOR (040-06S)	
26.	153-264	1	REDUCER (04N-06SF)	
27.	117-400	1	ABRASION SLEEVE (1.00" X 72")	
28.	515-330	1	HOSE (040FX45-76"-3000-AR)	
29.	154-275	1	BK CONNECTOR (040 -040BK)	
30.	117-612	1	ABRASION SLEEVE (1.00" X 46")	
31.	117-1019	1	ABRASION SLEEVE (1.25" X 234")	

FOOTNOTES:

- HOSE CONNECTS TO PUMP FOR JT4020 MACH I
- ENDS WITH S/N: CMWJ42T2J60000023; CMWA42T2E60000029; CMWA40T3P60000002; CMWJ40T3T60000001
- BEGINS WITH S/N: CMWA40T3K60000003; CMWJ40T3P60000002
- CONNECTS AT MAIN FRAME BULKHEAD

NOTE:

REFER TO O-RING CHART (800-301) IN BACK OF THE BOOK FOR REPLACEMENT OF O-RINGS.

MAIN FRAME BULKHEADS

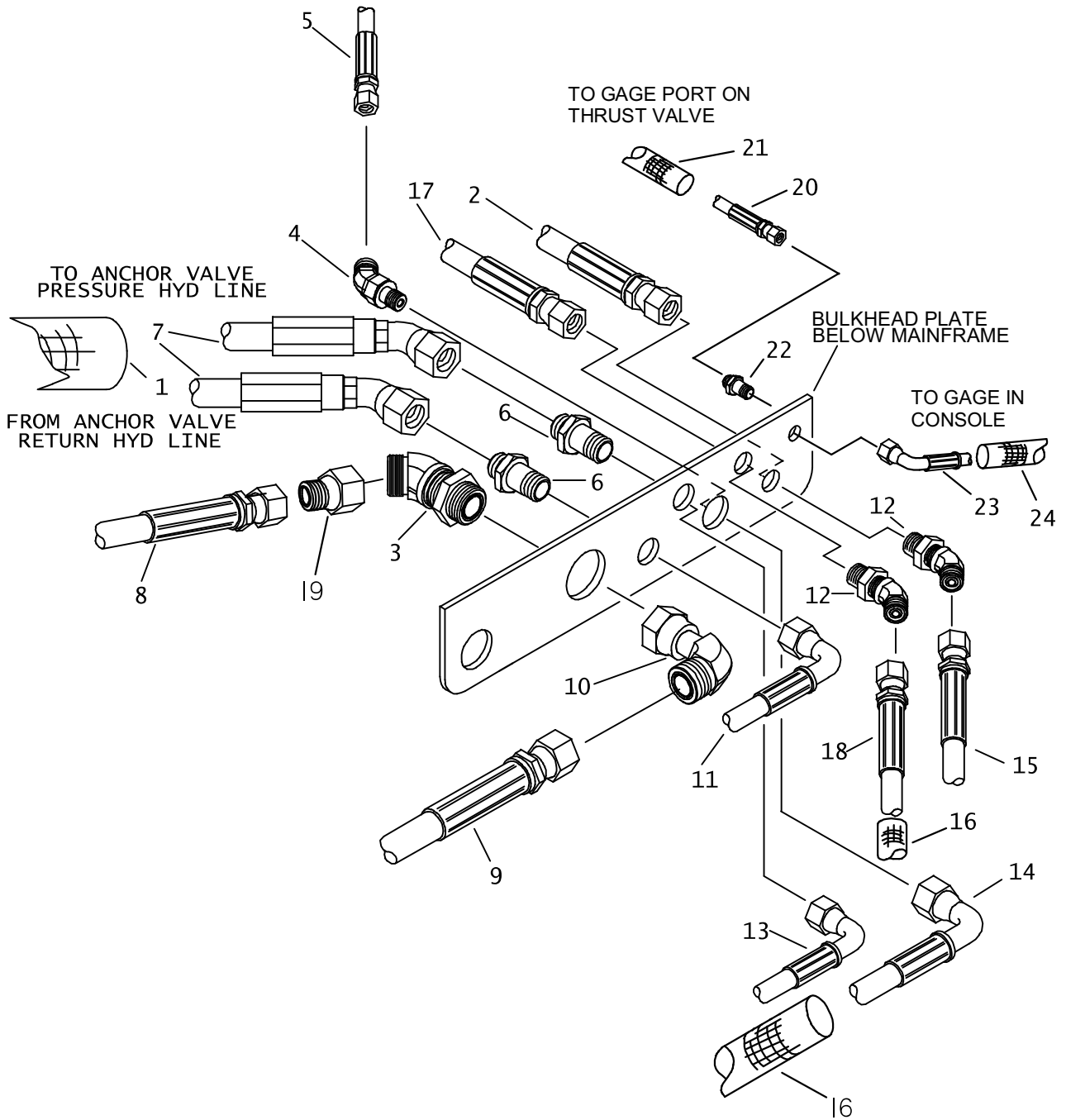

MAIN FRAME BULKHEADS

REF NO.	PART NUMBER	QTY	DESCRIPTION	REMARKS
1.	115-899	1	ABRASION SLEEVE (2.54" X 54")	
2.	515-141	1	HOSE (080FX90-82"-3000)	TO PIPE LOADER VALVE
3.	153-395	1	BK CONNECTOR (200-20045)	
4.	154-393	1	BK CONNECTOR (080-08045BK)	
5.	150-1979	1	HOSE (080FX-289"-3000)	TO ROTATION CASE DRAIN
6.	154-309	2	BK CONNECTOR (100-100BK)	
7.	515-671	2	HOSE (100FX45-52"-3000)	SEE GRAPHICS
8.	150-2065	1	HOSE (160FX-59"-3000)	TO TRACK DRIVE VALVE, SUPPLY
9.	157-754	1	HOSE (200FX45-27"-3000, SPEC)	FROM LOAD SENSE PUMP
10.	514-422	1	CONNECTOR (200-200FX90)	
11.	515-690	1	HOSE (100FX90L-58"-3000)	TO COOLER TUBE
12.	154-393	2	BK CONNECTOR (080-08045BK)	
13.	515-454	1	HOSE (100FX90L-20"-3000)	FROM LOAD SENSE PUMP
14.	515-379	1	HOSE (080FX90L-28"-3000)	TO HYDRAULIC TANK
15.	515-140	1	HOSE (080FX90-56"-3000)	FROM HYDRAULIC CONTROL VALVE ON HYD TANK
16.	117-684	2	ABRASION SLEEVE (1.00" X 26")	
17.	515-741	1	HOSE (080FX90S-112"-3000)	FROM DRAIN ON LOADER VALVE
18.	515-379	1	HOSE (080FX90L-28"-3000)	TEE WITH 515-379 ON HYDRAULIC TANK
19.	514-144	1	REDUCER (160-200)	
20.	150-1980	1	HOSE (040FX-282"-3000)	
21.	117-612	1	ABRASION SLEEVE (1.00" X 46")	
22.	154-275	1	BK CONNECTOR (040-040BK)	
23.	515-330	1	HOSE (040FX45-76"-3000-AR)	
24.	117-400	1	ABRASION SLEEVE (1.00" X 72")	

NOT SHOWN:

FOOTNOTES:

NOTE:

REFER TO O-RING CHART (800-301) IN BACK OF THE BOOK FOR REPLACEMENT OF O-RINGS.

ROTATION HYDRAULICS

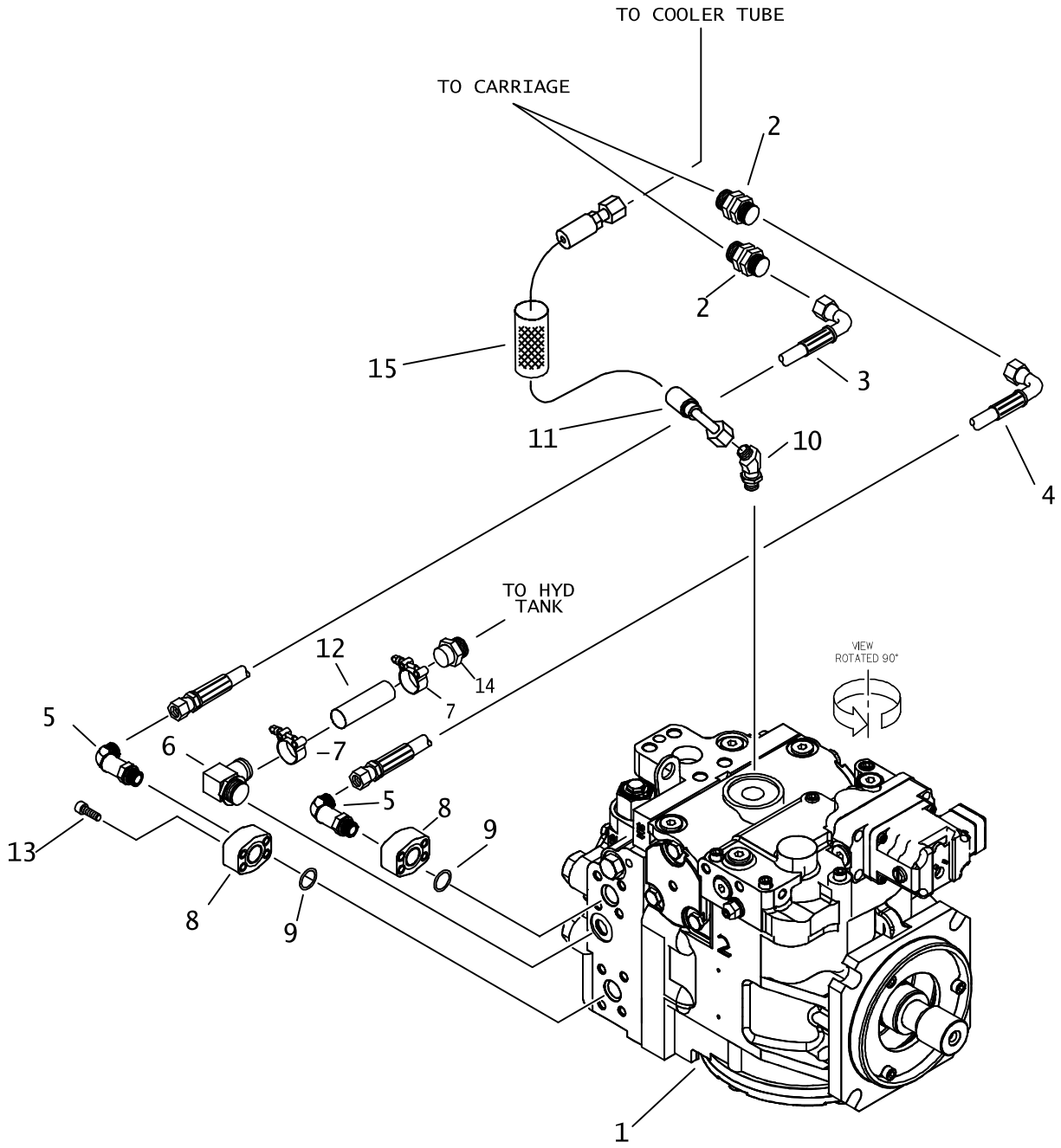

ROTATION HYDRAULICS

REF NO.	PART NUMBER	QTY	DESCRIPTION	REMARKS
1.	153-340	-	HYDRAULIC PUMP	SEAL KIT I90-764
2.	154-389	2	BK CONNECTOR (160-160BK)	
3.	515-666	1	HOSE (160FX90-52"-6000)	
4.	154-763	1	HOSE (160FX90S-54"-6000)	
5.	154-289	2	CONNECTOR (16S-16090, XL)	
6.	155-176	1	S/O COUPLER (20H-24S90)	
7.	111-028	2	T-BOLT CLAMP (1.75"-2.00")	
8.	514-245	2	HEAD FLANGE (16HFL-16SF)	
9.	157-029	2	O-RING (219 D90)	
10.	154-371	1	CONNECTOR (12S-16045)	
11.	156-177	1	HOSE (160FX45-38"-200)	CASE DRAIN
12.	116-588	AR	BULK HOSE (1-1/2", SOLD PER FT)	USE 1 @ 18.5"
13.	105-918	8	BOLT (7/16-NC X 1-1/2", SOC)	
14.	155-148	-	S/O COUPLER (20S-24H)	
15.	117-654	1	ABRASION SLEEVE (1.75" X 38")	

NOT SHOWN:

FOOTNOTES:

NOTE:

REFER TO O-RING CHART (800-301) IN BACK OF THE BOOK FOR REPLACEMENT OF O-RINGS.

ROTATION GAUGE VALVE JT 4020 T3

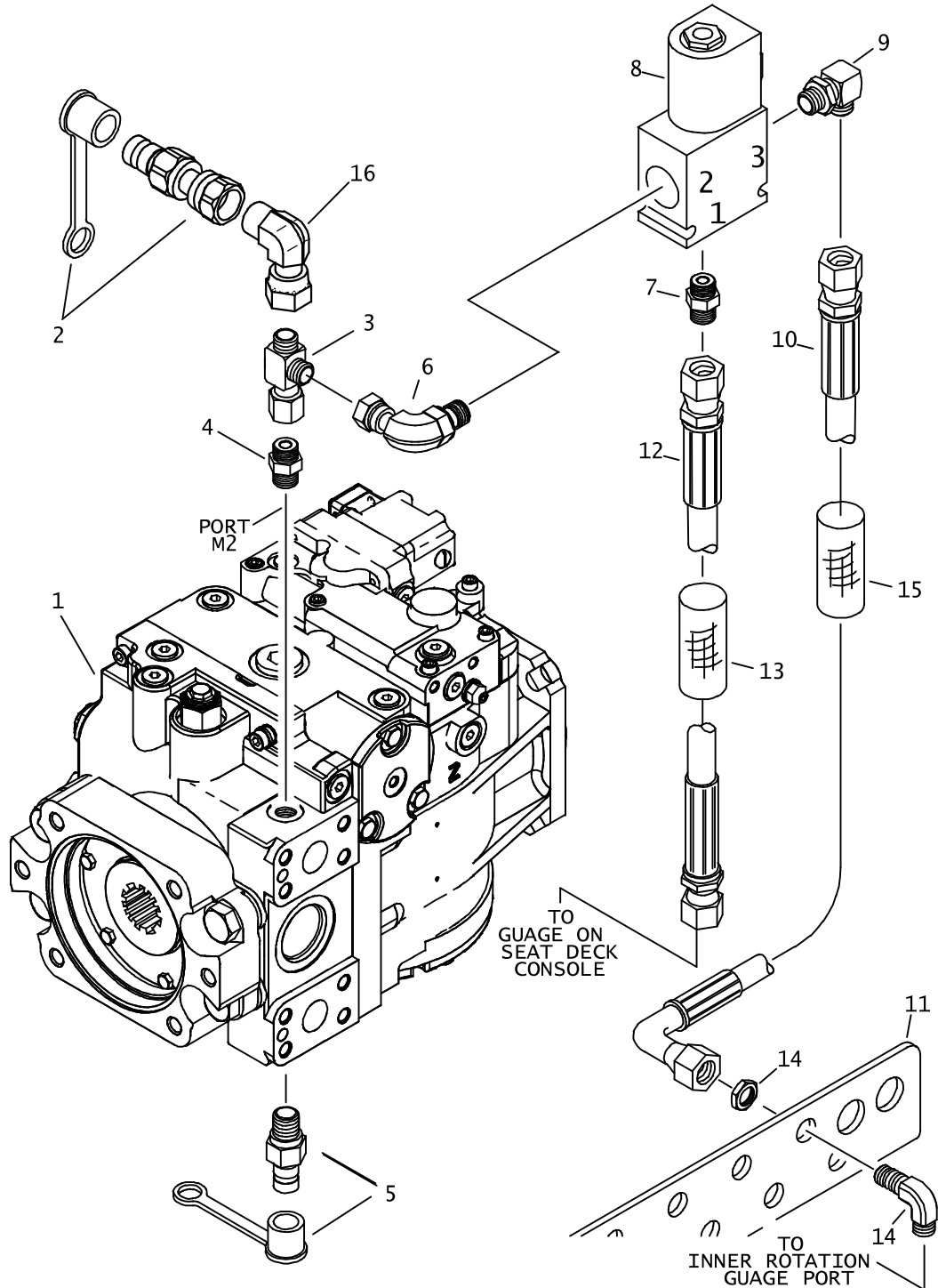

ROTATION GAUGE VALVE

JT 4020 T3

REF NO.	PART NUMBER	QTY	DESCRIPTION	REMARKS
1.	153-340	-	HYDRAULIC PUMP	
2.	159-157	1	QDC ADAPTER (02-060F)	
	159-148	-	DUST CAP (1/8")	
3.	154-344	1	UN RUN TEE (060FX-060-060)	
	154-221	1	CONNECTOR (06S-060)	
5.	159-147	1	QDC ADAPTER (02-06S)	
	159-148	-	DUST CAP (1/8")	
6.	154-343	1	UNION (06S-060FX90)	
7.	154-220	1	CONNECTOR (040-06S)	
8.	153-771	1	HYDRAULIC VALVE	
9.	154-226	1	CONNECTOR (040-06S90)	
10.	515-437	1	HOSE (040FX90-21"-3000)	
11.	354-466	-	BULKHEAD PLATE	
12.	153-730	-	HOSE (040FX-116"-6000)	
13.	117-792	-	ABRASION SLEEVE (1.00" X 115")	
14.	154-355	1	BK CONNECTOR (040-04090BK)	
15.	117-566	1	ABRASION SLEEVE (1.25" X 11")	
16.	154-228	1	UNION (060-060FX90)	

NOT SHOWN:

FOOTNOTES:

NOTE:

REFER TO O-RING CHART (800-301) IN BACK OF THE BOOK FOR REPLACEMENT OF O-RINGS.

ROTATION TEST PORTS

JT 4020 T3

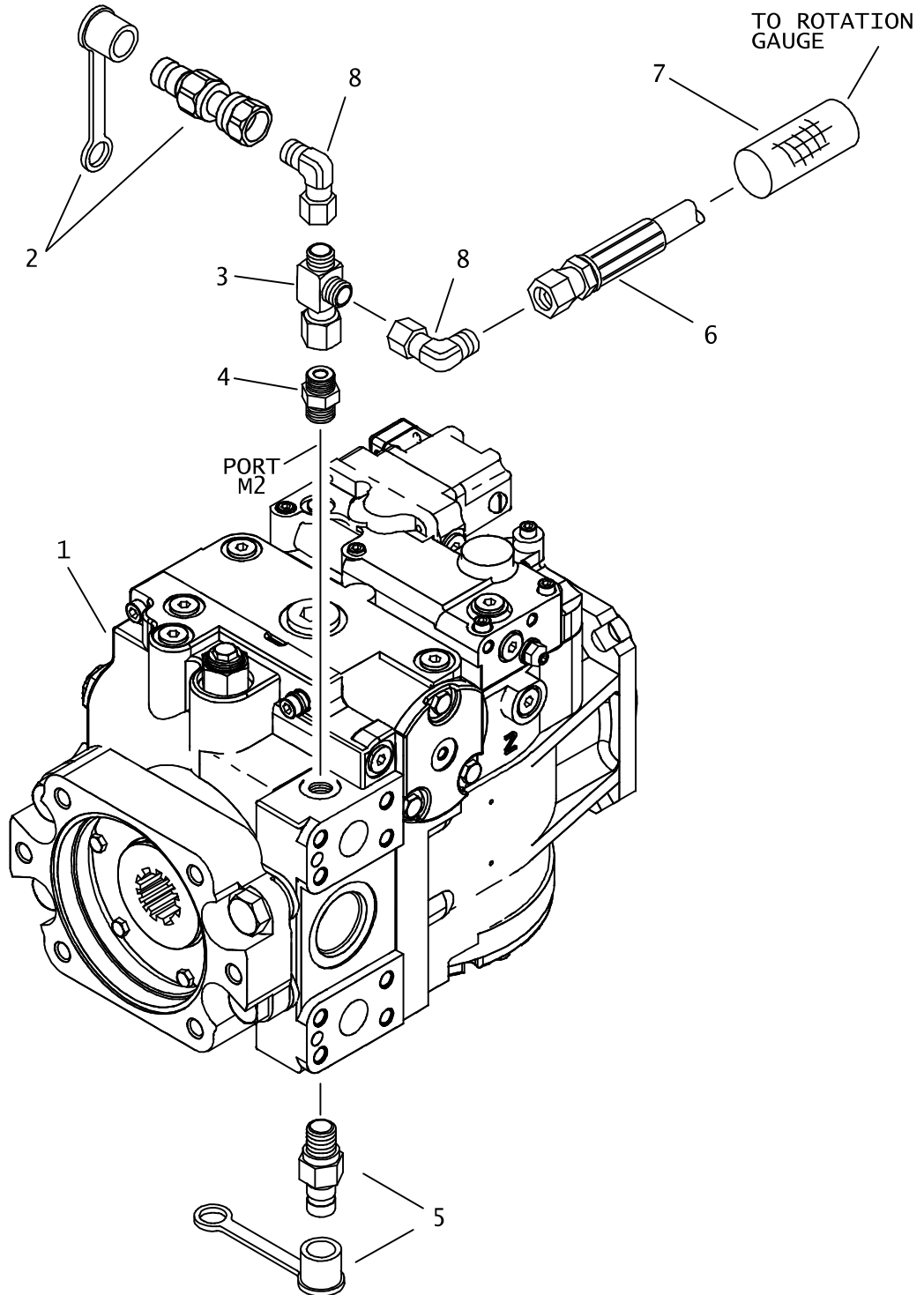

ROTATION TEST PORTS

JT 4020 T3

REF NO.	PART NUMBER	QTY	DESCRIPTION	REMARKS
1.	153-340	1	HYDRAULIC PUMP	
2.	159-156	1	QDC ADAPTER (02-040F)	
	159-148	-	DUST CAP (1/8")	
3.	154-265	1	UN RUN TEE (040FX-040-040)	
4.	154-220	1	CONNECTOR (040-06S)	
5.	159-147	1	QDC ADAPTER (02-06S)	
	159-148	-	DUST CAP (1/8")	
6.	153-730	1	HOSE (040FX-116"-6000)	
7.	117-792	1	ABRASION SLEEVE (1.00" X 115")	
8.	154-255	2	UNION (040-040FX90)	

NOT SHOWN:

FOOTNOTES:

NOTE:

REFER TO O-RING CHART (800-301) IN BACK OF THE BOOK FOR REPLACEMENT OF O-RINGS.

OUTER ROTATION HYDRAULICS

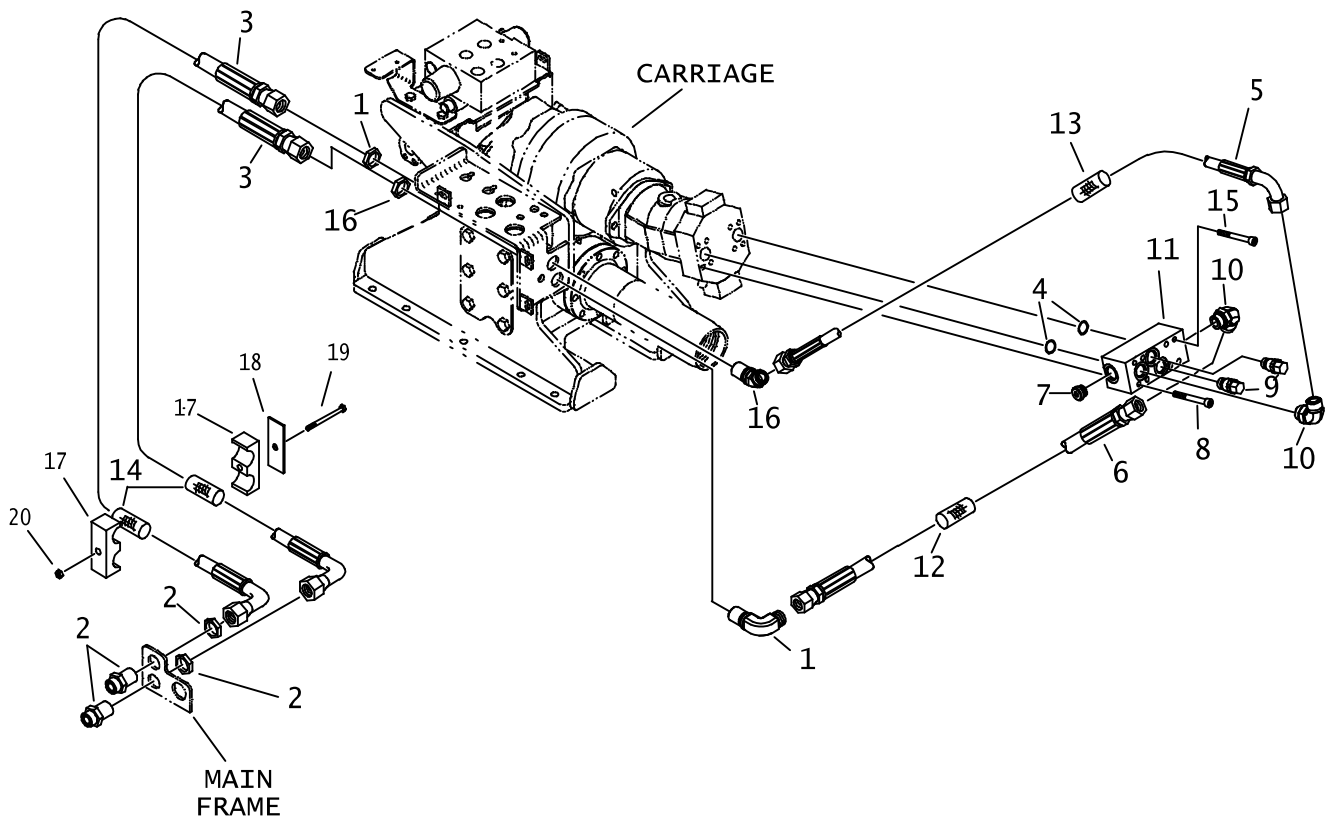

OUTER ROTATION HYDRAULICS

REF NO.	PART NUMBER	QTY	DESCRIPTION	REMARKS
1.	154-419	1	BK CONNECTOR (160-16090BK)	
2.	154-389	3	BK CONNECTOR (160-160BK)	
3.	153-744	2	HOSE (160FX90S-229"-6000)	
	150-1702	2	HOSE (160FX90S-299"-6000)	SEE FOOTNOTE 2
4.	157-029	2	O-RING (219 D90)	
5.	157-364	1	HOSE (160FX90S-18.75"-6000)	
6.	153-743	1	HOSE (160FX-24"-6000)	
7.	155-184	1	PLUG (16S)	
8.	107-806	4	SCR (7/16-NC X 3.50, SOC, GD8)	USE LOCTITE 242, TORQUE TO 85 FT LB
9.	149-566	2	HYDRAULIC VALVE	SEE FOOTNOTE 1
	191-031	-	SEAL REPAIR KIT	
10.	154-287	2	CONNECTOR (16S-16090)	
11.	157-363	1	CARTRIDGE MANIFOLD	
12.	117-675	1	ABRASION SLEEVE (1.75" X 24")	
13.	117-564	1	ABRASION SLEEVE (1.75" X 15")	
14.	117-292	2	ABRASION SLEEVE (2.07" X 70")	
15.	107-535	4	SCR (7/16-NC X 3.75, SOC, GD8)	USE LOCTITE 242, TORQUE TO 85 FT LBS
16.	514-242	1	BK CONNECTOR (160-16045BK)	
17.	110-359	1	BOLT-ON CLAMP (1-1/2", SET)	
18.	315-623	1	BACKUP SPACER	
19.	107-078	1	SCREW (M8-1.25 X 90MM)	
20.	106-561	1	LOCKNUT (M8-1.25, PRV TRQ, 10.9)	

NOT SHOWN:

FOOTNOTES:

1. TORQUE TO 80-90 FT LBS; TIGHTEN ONLY AT BASE DEEP SOCKET
2. USE ON 4020 WITH RACK AND PINION

NOTE:

- * REFER TO O-RING CHART (800-301) IN BACK OF THE BOOK FOR REPLACEMENT OF O-RINGS.
- * SEE PARTS PAGE ID0203288 FOR S/N BEGINNING WITH CMWJ40T3E80000063 & ENDING WITH S/N CMWJ40T3E80000082

OUTER ROTATION HYDRAULICS

BEGINS WITH S/N: CMWJ40T3E80000063

ENDS WITH S/N: CMWJ40T3T80000082

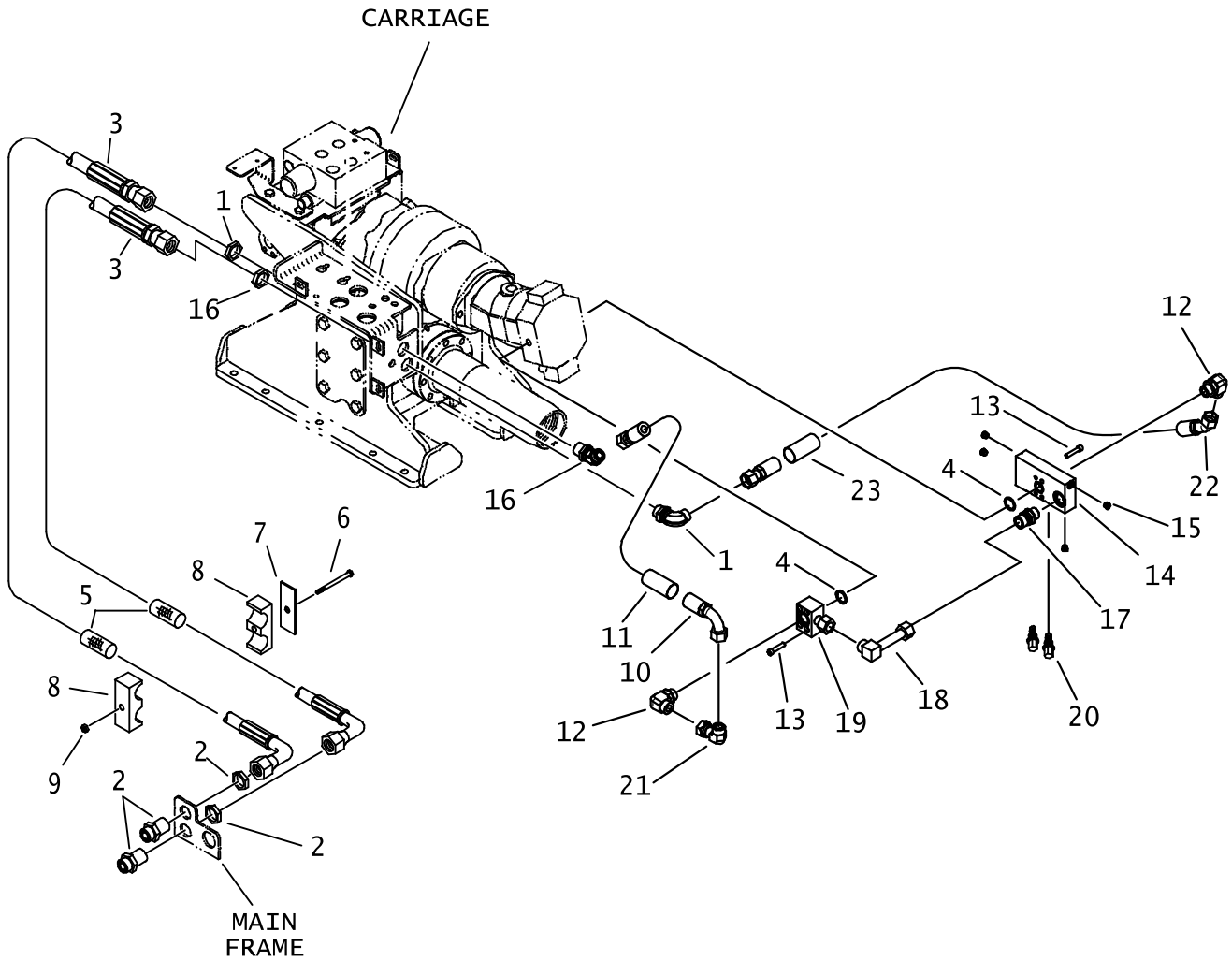

OUTER ROTATION HYDRAULICS

BEGINS WITH S/N: CMWJ40T3E80000063

ENDS WITH S/N: CMWJ40T3T80000082

REF NO.	PART NUMBER	QTY	DESCRIPTION	REMARKS
1.	154-419	1	BK CONNECTOR (160-16090BK)	
2.	154-389	3	BK CONNECTOR (160-160BK)	
3.	150-1702	2	HOSE (160FX90S-299"-6000)	
4.	157-029	2	O-RING (219 D90)	
5.	117-292	2	ABRASION SLEEVE (2.07" X 70")	
6.	107-078	1	SCREW (M8-1.25 X 90MM)	
7.	315-623	1	BACKUP SPACER	
8.	110-359	1	BOLT-ON CLAMP (1-1/2", SET)	
9.	106-561	1	LOCKNUT (M8-1.25, PRV TRQ, 10.9)	
10.	150-2142	1	HOSE (160FX90-14"-6000)	
11.	117-564	1	ABRASION SLEEVE (1.75" X 15")	
12.	154-287	2	CONNECTOR (16S-16090)	
13.	106-804	8	SCREW (7/16-NC X 2", SOC, GR8)	USE LOCTITE 242 TORQUE TO 85 FT LBS
14.	149-589	1	CARTRIDGE MANIFOLD	
15.	154-384	4	PLUG (06S)	
16.	514-242	1	BK CONNECTOR (160-16045BK)	
17.	149-377	1	HYDRAULIC ADAPTER, SPECIAL	
18.	149-425	1	UNION (160-16090, SPECIAL)	
19.	149-376	1	ADAPTER MANIFOLD	
20.	149-566	2	HYDRAULIC VALVE	TORQUE TO 80-90 FT. LBS, TIGHTEN ONLY AT BASE WITH DEEP SOCKET
21.	154-290	1	UNION (160-160FX90)	
22.	150-2143	1	HOSE (160FX45-19"-6000)	
23.	117-794	1	ABRASION SLEEVE (1.75" X 18")	

NOT SHOWN:

FOOTNOTES:

NOTE:

REFER TO O-RING CHART (800-30I) IN BACK OF THE BOOK FOR REPLACEMENT OF O-RINGS.

CASE DRAINS, AT

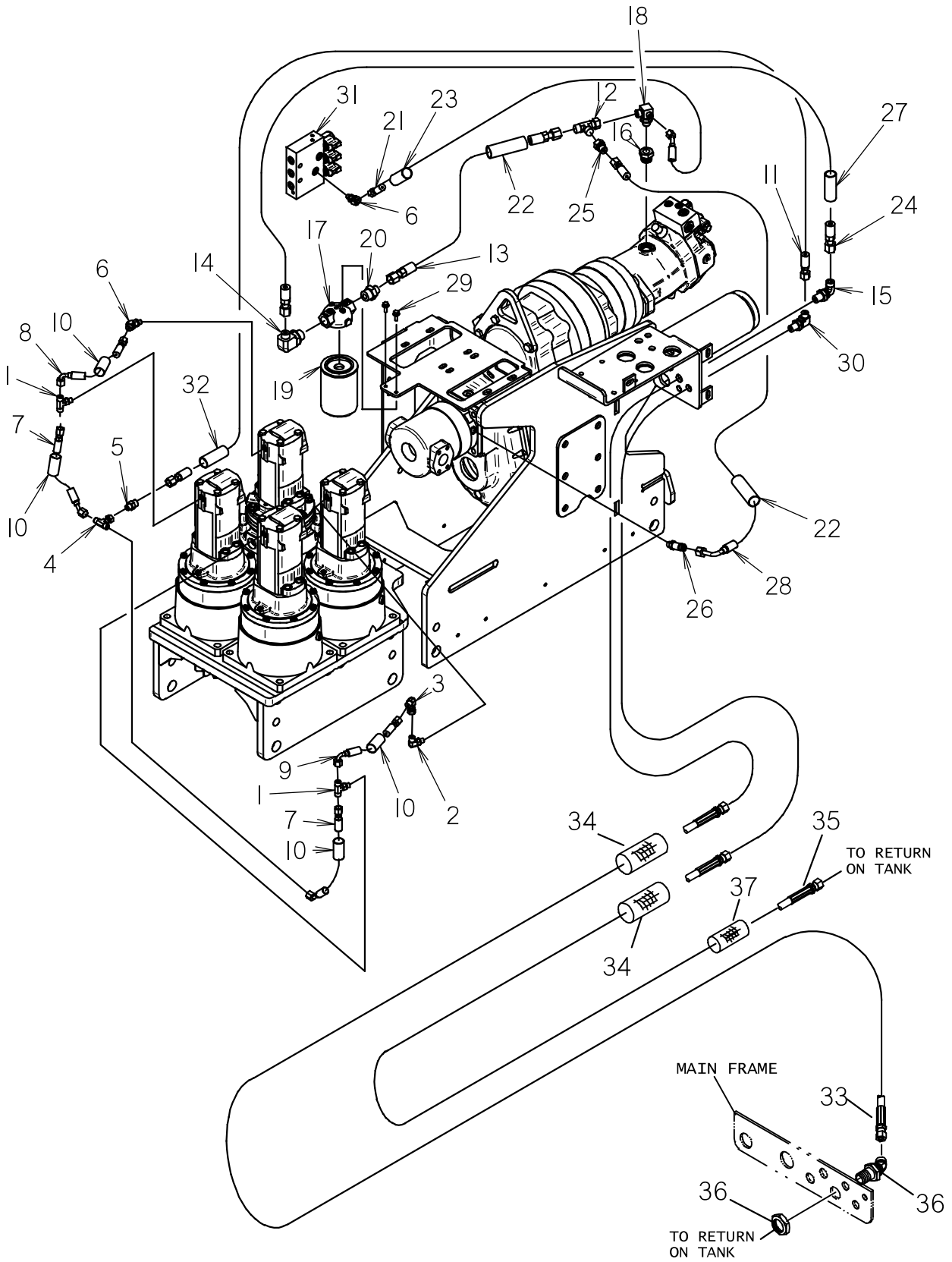

CASE DRAINS, AT

REF NO.	PART NUMBER	QTY	DESCRIPTION	REMARKS
1	I54-293	2	BRANCH TEE (04S-040-040)	
2	I54-252	1	CONNECTOR (04S-04090)	
3	I54-255	1	UNION (040-040FX90)	
4	I54-379	1	UN BR TEE (040FX-040-040)	
5	I54-408	1	CONNECTOR (040-060)	
6	I54-263	2	CONNECTOR (04S-04045)	
7	I50-1976	2	HOSE(040FX45-10"-3000)	
8	I53-309	1	HOSE(040FX90S-10.5"-3000)	
9	515-085	1	HOSE(040FX90-8.5"-3000)	
10	I17-982	4	ABRASION SLEEVE(1.00" X 6")	
11	I54-735	1	HOSE(060FX-70"-3000)	
12	I54-266	1	UNION RUN TEE (080FX-080-080)	
13	I54-739	1	HOSE (080FX-32"-3000)	
14	I54-236	1	CONNECTOR (080-12S90)	
15	I54-396	1	BK CONNECTOR (080-08090BK)	
16	I53-770	1	REDUCER (12S-8SF)	
17	I59-386	1	FILTER HEAD (12SF-12SF)	
18	514-160	1	BRANCH TEE (08S-080-040)	
19	I55-910	1	FILTER ELEMENT (1-UNF)	
20	I54-234	1	CONNECTOR (080-12S)	
21	515-425	1	HOSE(040FX45-42"-3000)	
22	I17-411	2	ABRASION SLEEVE (1.00" X 32")	
23	I17-387	1	ABRASION SLEEVE (1.00" X 42")	
24	I50-1565	1	HOSE(080FX-54"-3000)	
25	I54-262	1	REDUCER (060-080F)	
26	I56-174	1	CONNECTOR (06S-060 LG)	
27	I17-714	1	ABRASION SLEEVE (1.00" X 54")	
28	I53-769	1	HOSE(060FX90L-33"-3000)	
29	I06-168	2	FLG LK BOLT (1/4-NC X 3/4")	
30	I54-229	1	BK CONNECTOR (060-06090BK)	
31	I50-2005	1	CHARGE MANIFOLD	
32	I17-419	1	ABRASION SLEEVE (1.00" X 66")	

NOT SHOWN:

FOOTNOTES:

NOTE:

CASE DRAINS, AT

REF NO.	PART NUMBER	QTY	DESCRIPTION	REMARKS
33	I50-I979	1	HOSE I080FX-289"-3000)	SOCK WITH I50-I700
34	I17-327	2	ABRASION SLEEVE (I.59" X 23I"1)	
35	I50-I70I	1	HOSE I060FX-280"-3000)	SOCK WITH I50-I980
36	I54-393	1	BK CONNECTOR (080-08045BK)	
37	I17-6I2	1	ABRASION SLEEVE II.00" X 46")	

NOT SHOWN:

FOOTNOTES:

NOTE:

CASE DRAINS, JT

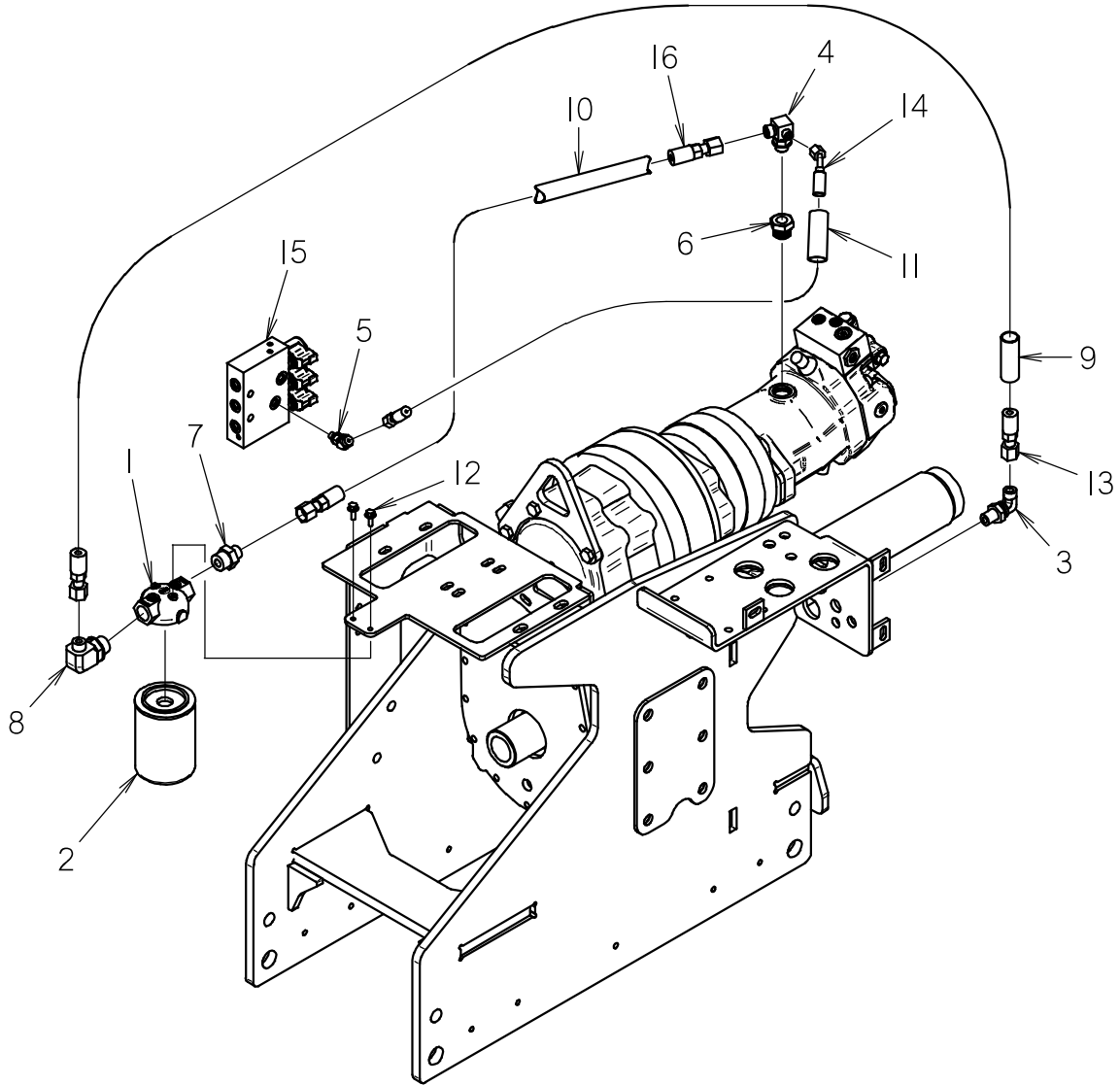

CASE DRAINS, JT

REF NO.	PART NUMBER	QTY	DESCRIPTION	REMARKS
1	159-386	1	FILTER HEAD (12SF-12SF)	
2	155-910	1	FILTER ELEMENT (1-UNF)	
3	154-396	1	BK CONNECTOR (080-08090BK)	
4	514-160	1	BRANCH TEE (08S-080-040)	
5	154-263	1	CONNECTOR (04S-04045)	
6	153-770	1	REDUCER (12S-8SF)	
7	154-234	1	CONNECTOR (080-12S)	
8	154-236	1	CONNECTOR (080-12S90)	
9	117-714	1	ABRASION SLEEVE (1.00" X 54")	
10	117-412	1	ABRASION SLEEVE (1.00" X 34")	
11	117-387	1	ABRASION SLEEVE (1.00" X 42")	
12	106-168	2	FLG LK BOLT (1/4-NC X 3/4")	
13	150-1565	1	HOSE(080FX-54"-3000)	
14	515-425	1	HOSE(040FX45-42"-3000)	
15	150-2005	1	CHARGE MANIFOLD	
16	154-708	1	HOSE (080FX-34"-3000)	

NOT SHOWN:

FOOTNOTES:

NOTE:

FOR THRUST DRIVE CASE DRAINS USE THE AT VERSION CASE DRAINS PAGE.

REMOTE FILTER JT 4020 T3

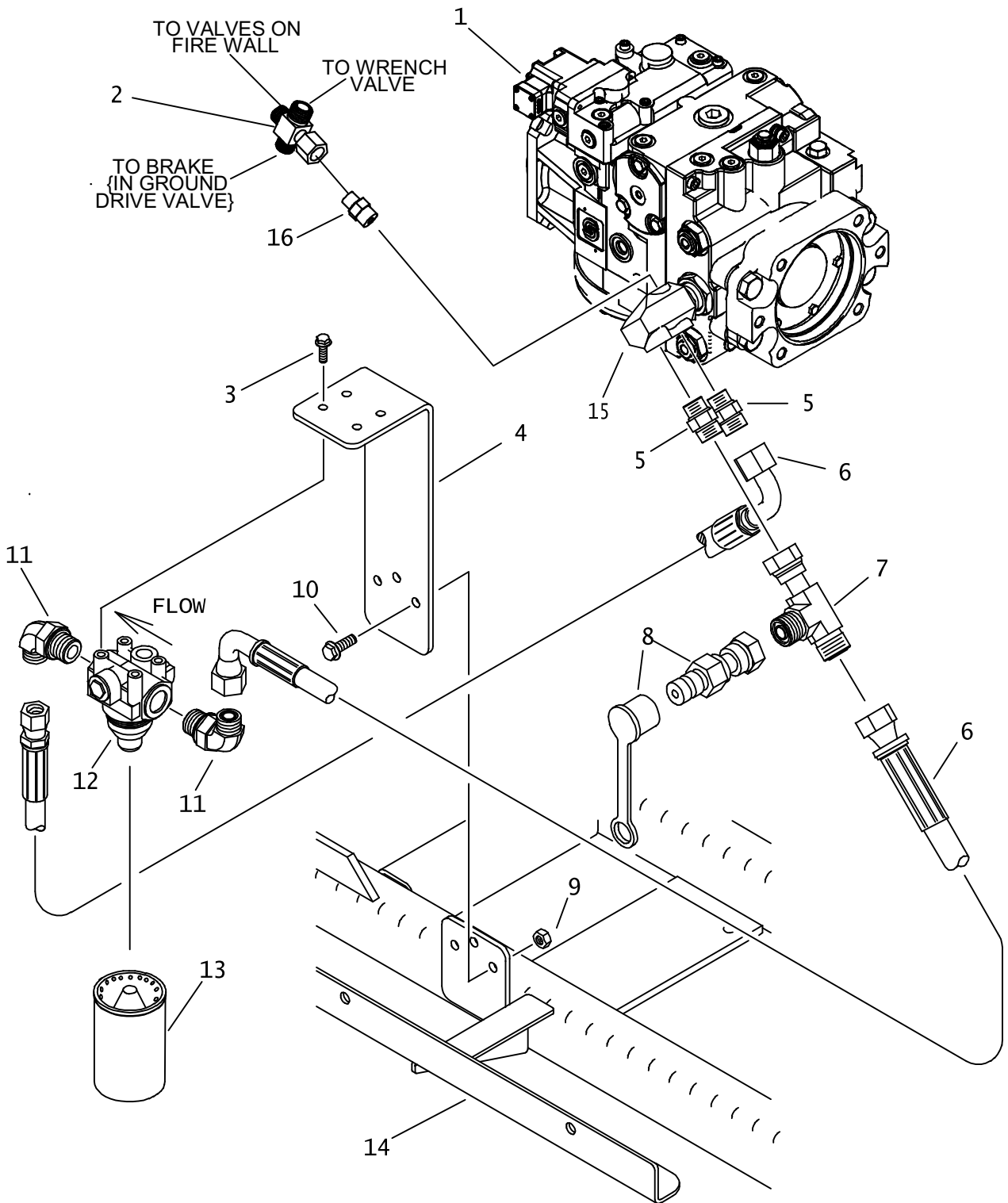

REMOTE FILTER

JT 4020 T3

REF NO.	PART NUMBER	QTY	DESCRIPTION	REMARKS
1.	153-340	-	HYDRAULIC PUMP	INCLUDES ITEM 15
2.	150-1097	1	SPECIAL CROSS (F060-060-080-060)	
3.	105-823	4	FLG LK BOLT (5/16-NC Xf")	
4.	310-571	1	CHARGE FILTER BRACKET	
5.	154-301	2	CONNECTOR (10S-100)	
6.	153-268	2	HOSE (100FX90S-24"-1500)	
7.	154-488	1	UN RUN TEE (100FX-100-100)	
8.	159-159	1	QDC ADAPTER (02-100FX)	
	159-148	-	DUST CAP (1/8")	
9.	105-894	3	LOCKNUT(M10-1.50,PRV TRQ,10.9)	
10.	106-724	3	FLG SCREW (M10-1.50 X 25MM)	
11.	154-300	2	CONNECTOR (100-12S90)	
12.	153-050	1	FILTER HEAD (12 SF)	
13.	149-939	1	FILTER	
14.	354-597	-	ENGINE SKID	
15.	149-845	-	REMOTE FILTRATION KIT (75/100)	PART OF ITEM 1, INCLUDES O-RING
16.	154-221	1	CONNECTOR (06S-060)	

NOT SHOWN:

FOOTNOTES:

NOTE:

REFER TO O-RING CHART (800-301) IN BACK OF THE BOOK FOR REPLACEMENT OF O-RINGS.

TRACK 2-SPEED

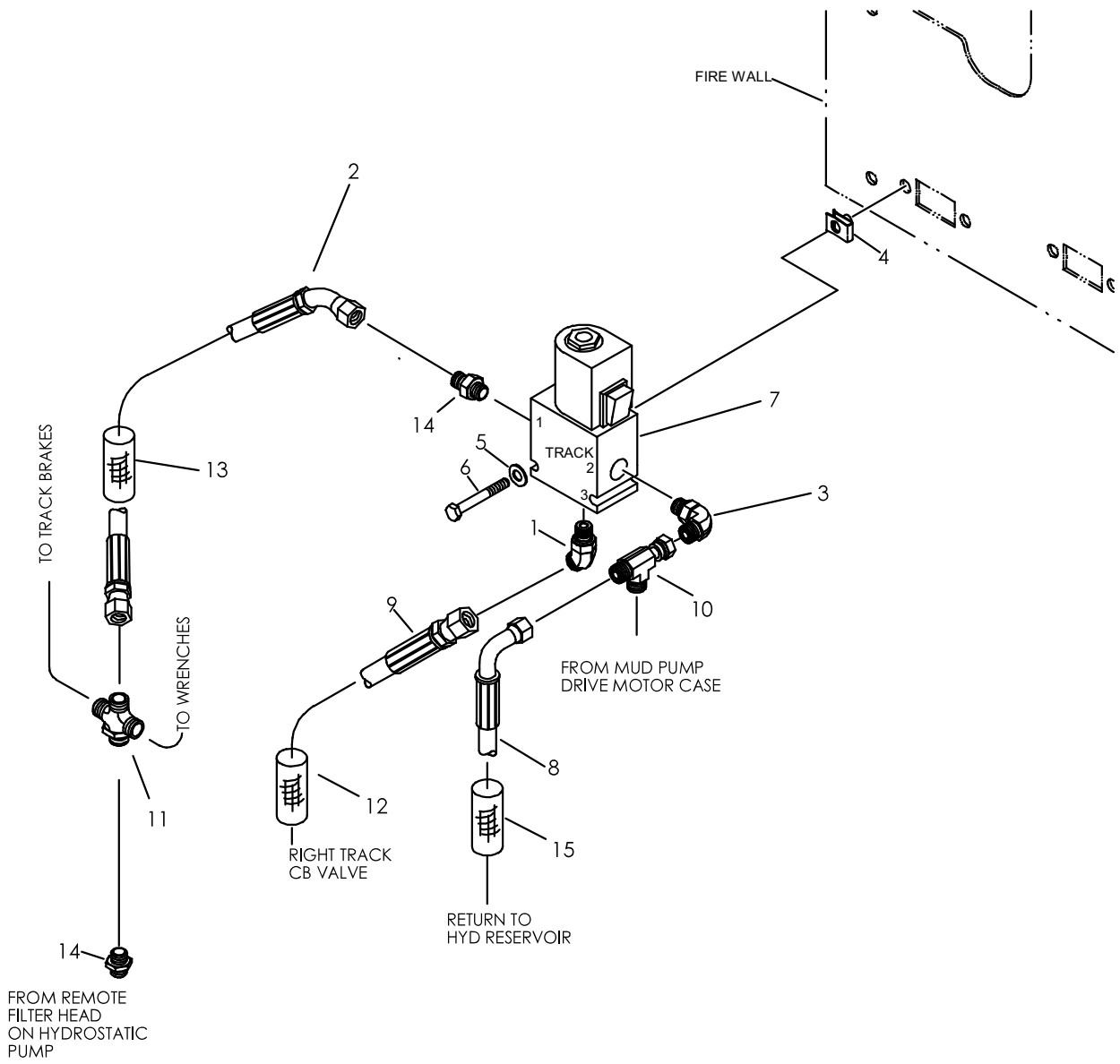

TRACK 2-SPEED

REF NO.	PART NUMBER	QTY	DESCRIPTION	REMARKS
1.	154-224	1	CONNECTOR (06S-06045)	
2.	515-587	1	HOSE (060FX45-20"-3000)	
3.	154-342	1	CONNECTOR (06S-06090)	
4.	106-574	2	CLIP NUT (M6-1.00)	
5.	106-076	2	WASHER (1/4")	
6.	107-025	2	SCREW (M6-1.0 X 50mm)	
7.	158-627	1	SOLENOID VALVE	
	500-756	1	SEAL REPAIR KIT	
	217-770	1	SOLENOID COIL	
	158-636	1	SOLENOID VALVE CARTRIDGE	
8.	153-315	1	HOSE (060FX90S-36"-3000)	
9.	154-806	1	HOSE (060FX-54"-3000)	
10.	154-344	1	UNION RUN TEE (060FX-060-060)	
11.	150-1097	-	SPECIAL CROSS (F060-060-080-060)	
12.	117-395	1	ABRASION SLEEVE (1.25" X 50")	
13.	117-328	1	ABRASION SLEEVE (1.00" X 18")	
14.	154-221	2	CONNECTOR (06S-060)	
15.	117-412	1	ABRASION SLEEVE (1.00" X 34")	

NOT SHOWN:

FOOTNOTES:

NOTE:

SPINDLE BRAKE, THRUST BRAKE, AND 2-SPEED

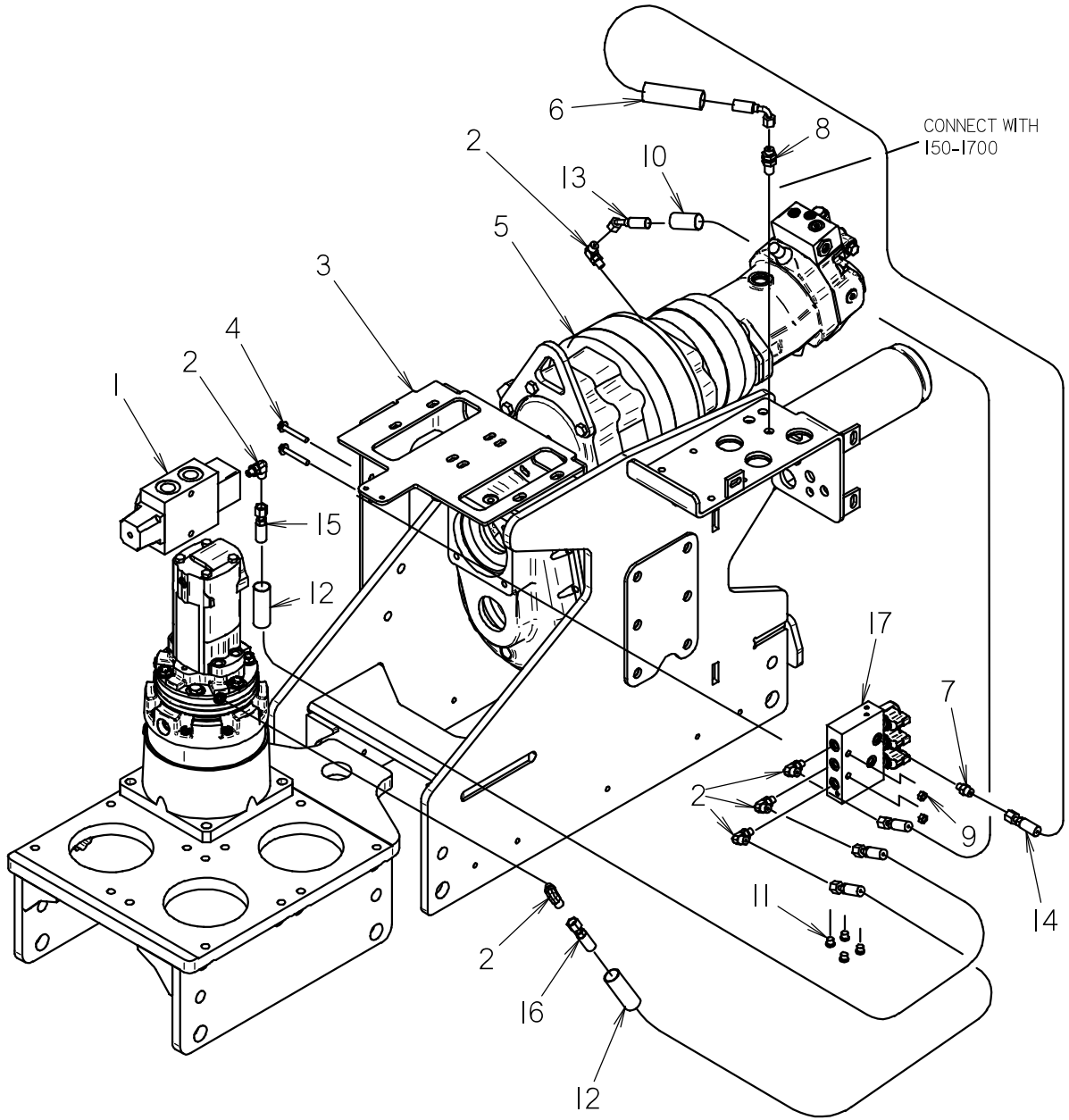

SPINDLE BRAKE, THRUST BRAKE, AND 2-SPEED

REF NO.	PART NUMBER	QTY	DESCRIPTION	REMARKS
1	I49-343	1	HYDRAULIC CONTROL VALVE	
2	I54-252	6	CONNECTOR (04S-04090)	
3	327-I074	1	VALVE MOUNT BRACKET	
4	I05-665	2	FLG SCREW (M8-I.25 X 55MM)	
5	I66-396	1	AT4020 ROTATION DRIVE	
6	I17-411	1	ABRASION SLEEVE (I.00" X 32")	
7	I54-278	1	CONNECTOR (04S-040)	
8	I54-275	1	BK CONNECTOR (040-040BK)	
9	I06-561	2	LOCKNUT (M8-I.25,PRV TRQ,I0.9)	
10	I17-612	1	ABRASION SLEEVE (I.00" X 46")	
11	I54-383	4	PLUG (04S)	
12	I17-409	2	ABRASION SLEEVE (I.00" X 28")	
13	515-I35	1	HOSE(I040FX45-48"-3000)	
14	515-011	1	HOSE(I040FX90-32"-3000)	
15	515-509	1	HOSE(I040FX-28"-3000)	
16	515-509	1	HOSE(I040FX-28"-3000)	
17	I50-2005	1	CHARGE MANIFOLD	

NOT SHOWN:

FOOTNOTES:

NOTE:

TRACK SHIFT

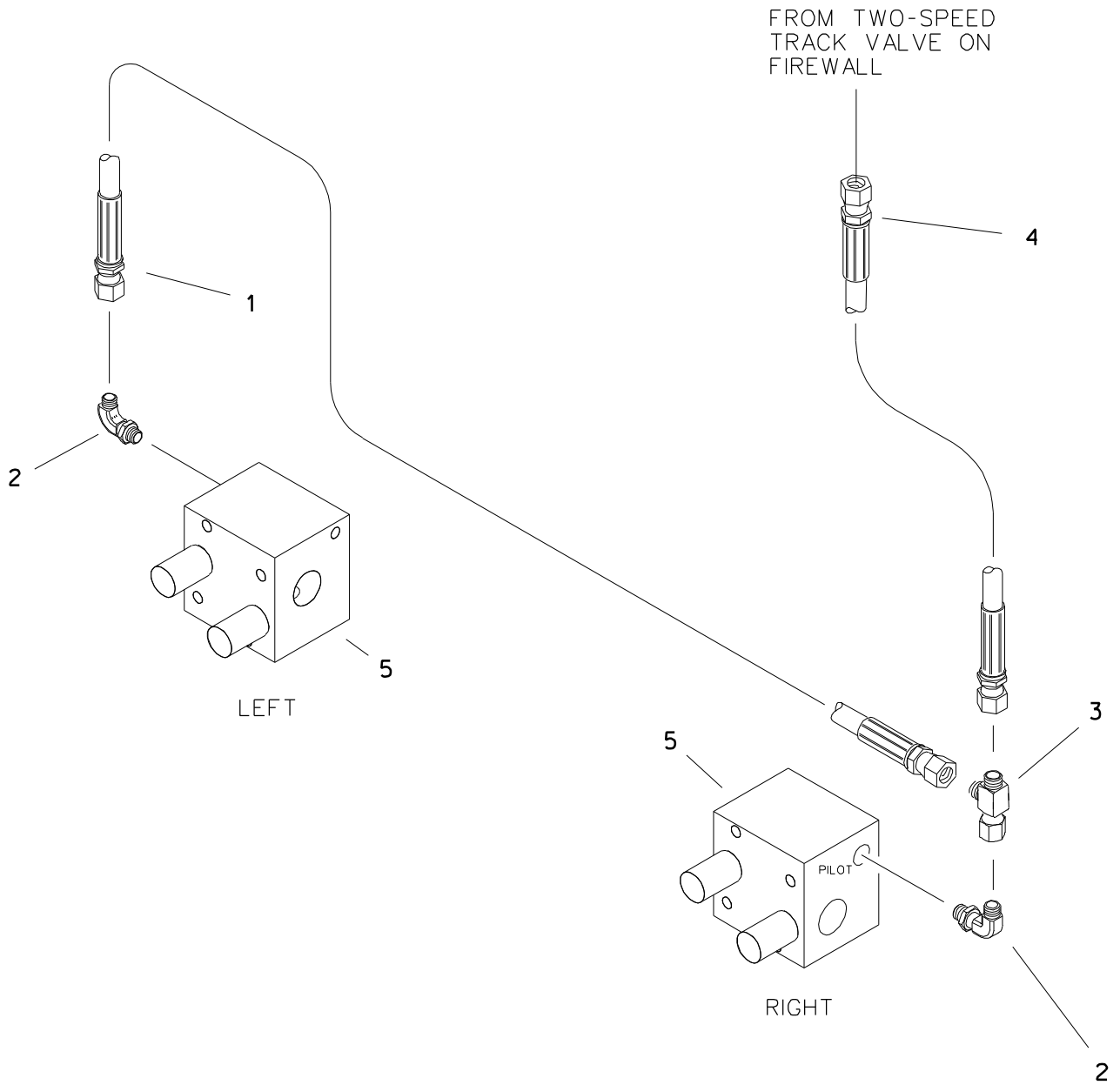

TRACK SHIFT

REF NO.	PART NUMBER	QTY	DESCRIPTION	REMARKS
1.	154-797	1	HOSE (060FX-48"-3000)	
2.	514-049	2	CONNECTOR (04S-06090)	
3.	154-344	1	UNION RUN TEE (060FX-060-060)	
4.	154-806	1	HOSE (060FX-54"-3000)	
5.	153-767	-	COUNTERBALANCE MANIFOLD	SERVICE CARTRIDGE

FOOTNOTES

NOTE
REFER TO O-RING CHART (800-301) IN BACK OF THE BOOK FOR REPLACEMENT OF O-RINGS.

TRACK BRAKE

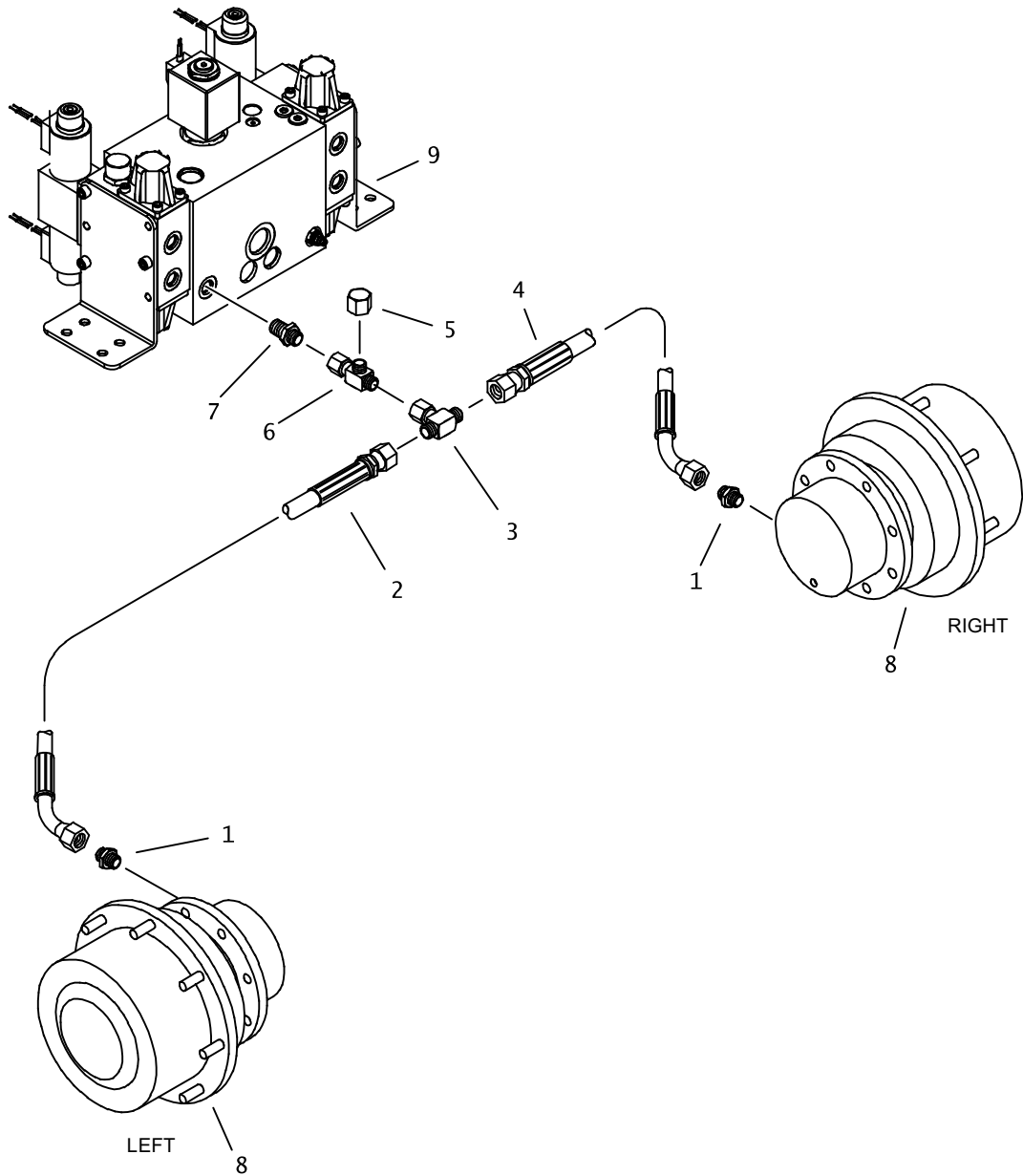

TRACK BRAKE

REF PART NO. NUMBER	QTY	DESCRIPTION	REMARKS
1. 154-411	2	CONNECTOR (04S-060)	
2. 515-188	1	HOSE (060FX90S-23"-3000)	
3. 154-348	1	UNION BR TEE (060FX-060-060)	
4. 154-738	1	HOSE (060FX90-34"-3000)	
5. 154-326	1	CAP (060F)	
6. 154-344	1	UNION RUN TEE (060FX-060-060)	
7. 154-221	1	CONNECTOR (06S-060)	
8. 166-285	2	PLANETARY GEARBOX	
		157-613 - INTERNAL SEAL	
		500-2029 - RETAINER RING, INTERNAL	
9. 153-639	-	HYD CONTROL VALVE	SEE FOOTNOTE 1

NOT SHOWN:

FOOTNOTES:

153-639 IS SUPERSEDED BY 150-1815

NOTE:

REFER TO O-RING CHART (800-301) IN BACK OF THE BOOK FOR REPLACEMENT OF O-RINGS.

FLUID CHECK SUPPLY HYDRAULICS

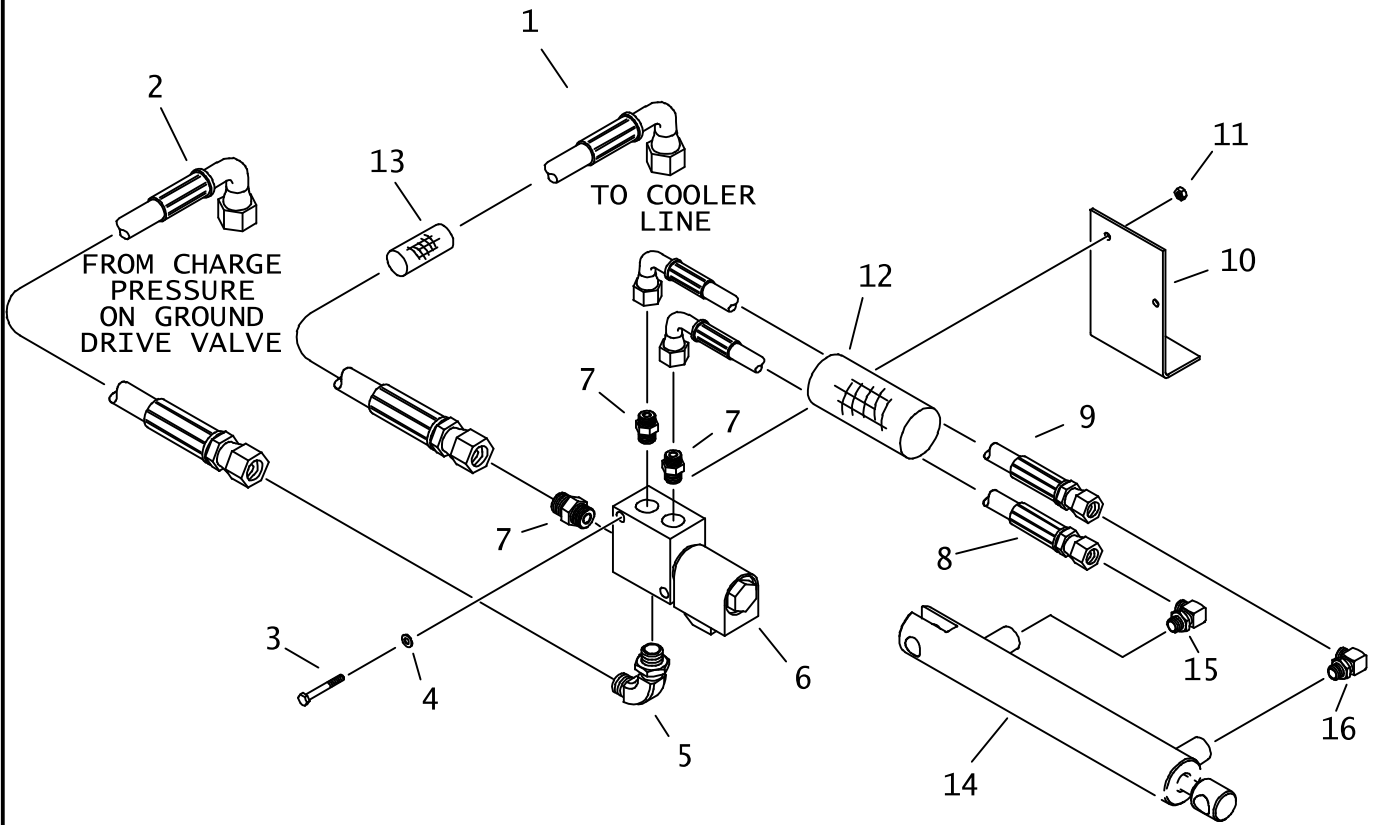

FLUID CHECK SUPPLY HYDRAULICS

REF NO.	PART NUMBER	QTY	DESCRIPTION	REMARKS
1.	515-696	1	HOSE (040FX90M-58"-3000)	
2.	515-583	1	HOSE (060FX90-12"-3000)	
3.	107-025	2	SCREW (M6-1.00 X 50MM)	
4.	105-095	2	WASHER (1/4")	
5.	154-342	1	CONNECTOR (06S-06090)	
6.	149-550	1	SOLENOID CONTROL VALVE	
	214-491	1	COIL (12V)	
7.	154-220	3	CONNECTOR (040-06S)	
8.	515-074	1	HOSE (040FX90-77"-3000)	
9.	154-982	1	HOSE (040FX90S-80"-3000)	
10.	310-637	1	VALVE BRACKET	
11.	106-538	1	LOCKNUT (M6-1.00,PRV TRQ,10.9)	
12.	115-963	1	ABRASION SLEEVE (1.59" X 75")	
13.	117-326	1	ABRASION SLEEVE (1.00" X 58")	
14.	150-727	-	CYL (1.0" X .500" X 4.0")	
15.	154-401	1	CONNECTOR (04S-04090, ORF)	
16.	154-252	1	CONNECTOR (04S-04090)	

NOT SHOWN:

FOOTNOTES:

NOTE:

REFER TO O-RING CHART (800-301) IN BACK OF THE BOOK FOR REPLACEMENT OF O-RINGS

TRACK LOAD SENSE HYDRAULICS

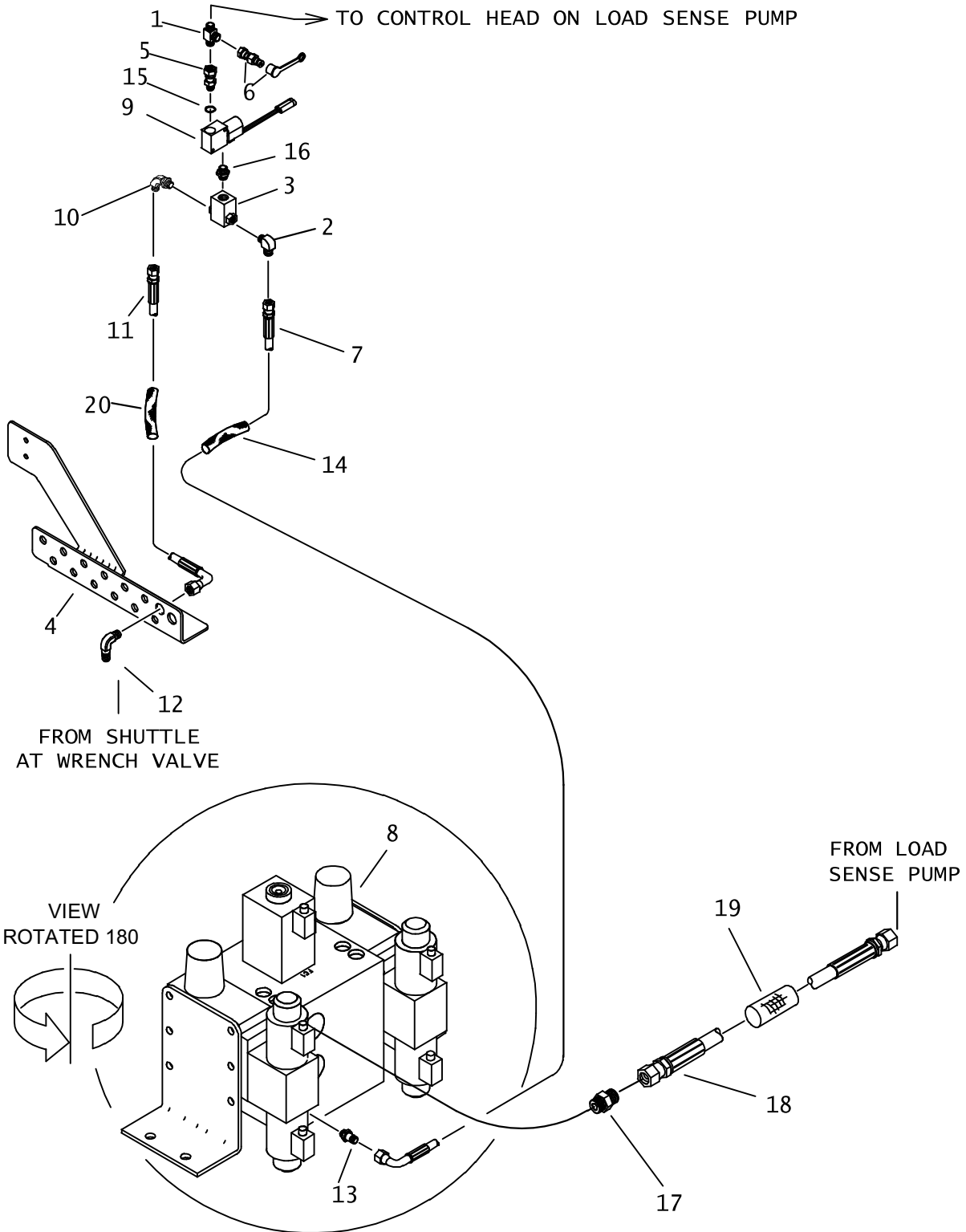

TRACK LOAD SENSE HYDRAULICS

REF NO.	PART NUMBER	QTY	DESCRIPTION	REMARKS
1.	154-345	1	RUN TEE (06S-060-060)	
2.	157-420	1	CONN(06S-06090, ORF .028)	
3.	158-600	1	HYD SHUTTLE VALVE	NOT SERVICABLE PER SUPPLIER
4.	354-466	-	BULKHEAD PLATE	
5.	514-409	1	UNION (06J-060FX)	
6.	159-157	1	QDC ADAPTER (02-060F)	
	159-148	-	DUST CAP (1/8")	
7.	157-962	1	HOSE (060FX90M-78"-3000)	
8.	150-1815	1	HYD CONTROL VALVE	
	217-897		SOLENOID COIL (LARGE)	
	214-434		SOLENOID COIL (SMALL)	
	149-565		3-WAY CARTRIDGE VALVE	
	150-1525		PROPORTIONAL VALVE	
9.	158-661	1	HYD CONTROL VALVE	
	500-757	-	SEAL REPAIR KIT	
	214-491	-	COIL, 12V	
10.	154-342	1	CONNECTOR (06S-06090)	
11.	154-887	1	HOSE (060FX45-23"-3000)	
12.	154-229	1	BK CONNECTOR (060-06090BK)	
13.	154-411	2	CONNECTOR (04S-060)	
14.	117-713	1	ABRASION SLEEVE (1.00" X 76")	
15.	155-705	1	O-RING (906 D90)	
16.	155-153	1	CONNECTOR (06S-06S)	
17.	154-281	1	CONNECTOR (16S-160)	
18.	150-2065	1	HOSE (160FX-59"-3000)	
19.	115-894	1	ABRASION SLEEVE (2.38" X 60")	
20.	117-622	1	ABRASION SLEEVE (1.25" X 20")	

NOT SHOWN:

FOOTNOTES:

NOTE:

THRUST VALVE / LOAD SENSE, AT

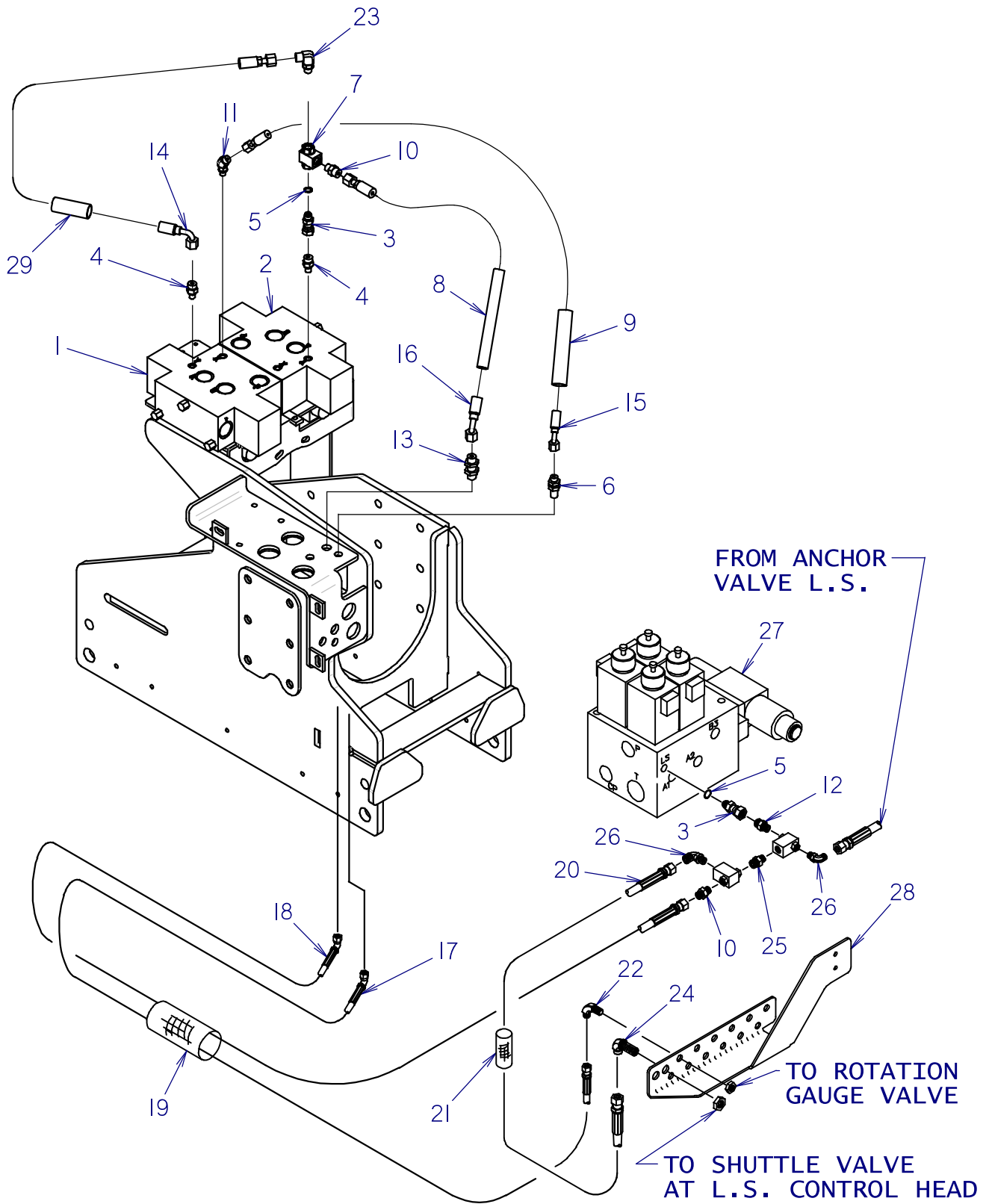

THRUST VALVE / LOAD SENSE, AT

REF NO.	PART NUMBER	QTY	DESCRIPTION	REMARKS
1	153-773	1	INNER ROTATION VALVE	SEE FOOTNOTE 1
2	150-2712	1	THRUST VALVE	
3	514-409	2	UNION (06J-060FX)	
4	154-411	2	CONNECTOR (04S-060)	
5	155-705	2	O-RING (906 D90)	
6	154-275	1	BK CONNECTOR (040-040BK)	
7	158-600	3	LSVI LOAD SHUTTLE	
8	117-993	1	ABRASION SLEEVE (1.00" X 23")	
9	117-411	1	ABRASION SLEEVE (1.00" X 32")	
10	154-221	2	CONNECTOR (06S-060)	
11	154-263	1	CONNECTOR (04S-04045)	
12	156-067	1	CONNECTOR (06S-060, ORF .031)	
13	514-163	1	BK CONNECTOR (060-060BK)	
14	153-316	1	HOSE (060FX90S-25"-3000)	
15	159-838	1	HOSE(040FX45-33-3000)	
16	154-887	1	HOSE(060FX45-23"-3000)	
17	150-1700	1	HOSE (040FX45-282"-3000)	
18	150-1709	1	HOSE (060FX45-302"-3000)	SEE FOOTNOTE 2
	150-3323	1	HOSE (060FX45-295"-3000)	SEE FOOTNOTE 3
19	117-327	1	ABRASION SLEEVE (1.25" X 234")	
20	154-816	1	HOSE (060FX-120"-3000)	
21	117-212	1	ABRASION SLEEVE (1.25" X 118")	
22	154-355	1	BK CONNECTOR (040-04090BK)	
23	157-420	1	CONN (06S-06090, ORF .028)	
24	154-229	1	BK CONNECTOR (060-06090BK)	
25	155-153	1	CONNECTOR (06S-06S)	
26	154-342	2	CONNECTOR (06S-06090)	
27	153-410	1	HYDRAULIC VALVE	
28	354-466	1	BULKHEAD PLATE	
29	117-989	1	ABRASION SLEEVE (1.00" X 24")	

NOT SHOWN:

FOOTNOTES:

1. SET DAMPING ORIFICE OUT 3 TURNS FROM BOTTOM.
2. ENDS WITH S/No's CMWA40T3PB0000138, AND CMWJ40T3CB0000136
3. BEGINS WITH S/No's CMWJ40T3TB0000137, AND CMWA40T3KB0000139

NOTE:

REFER TO O-RING CHART (800-301) ON BACK OF THE BOOK FOR REPLACEMENT OF O-RINGS.

INNER ROTATION & THRUST HYDRAULICS

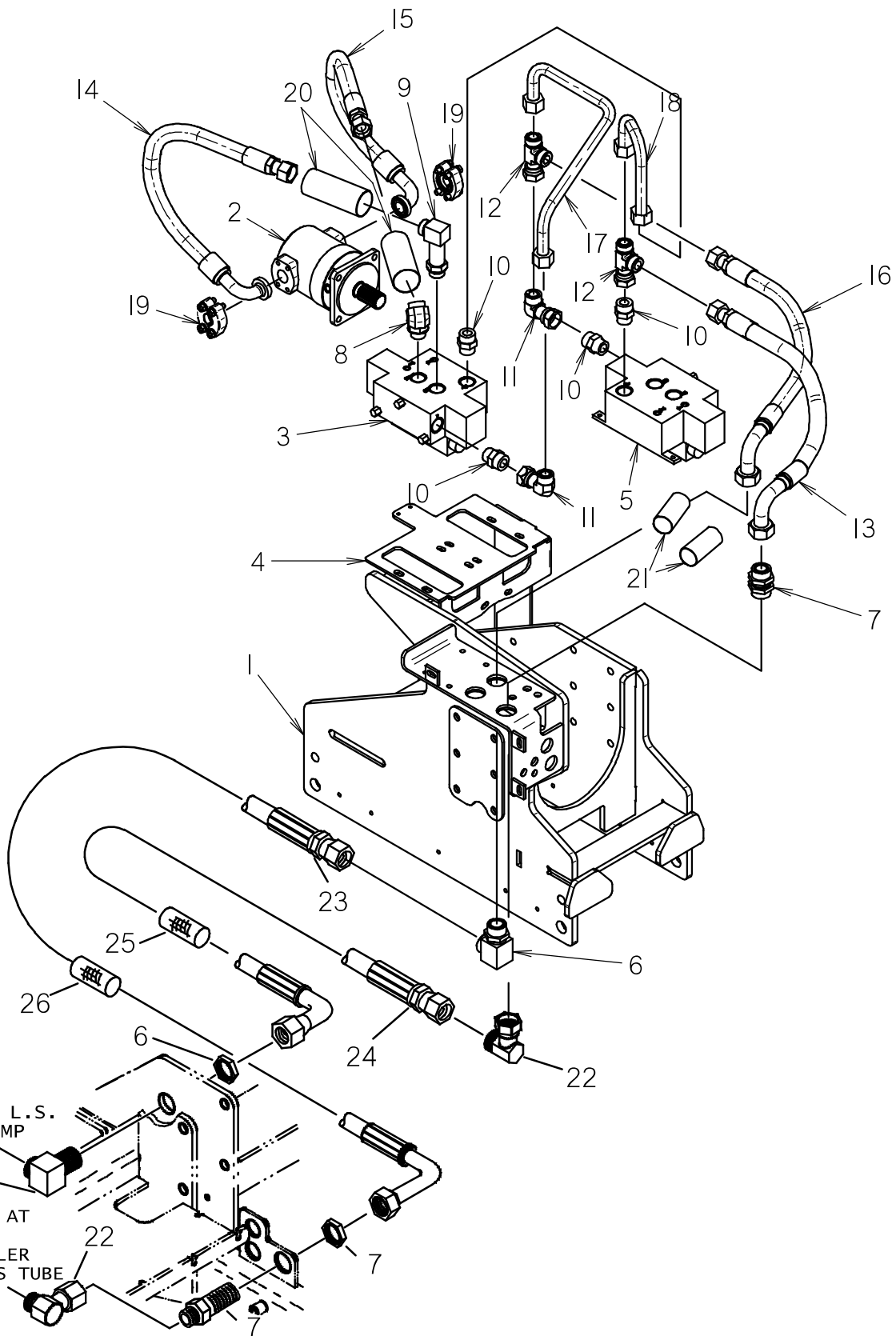

INNER ROTATION & THRUST HYDRAULICS

REF NO.	PART NUMBER	QTY	DESCRIPTION	REMARKS
1	327-1043	1	4020 RACK CARRIAGE	
2	153-612	1	HYDRAULIC MOTOR	
3	153-773	1	INNER ROTATION VALVE	
4	327-1074	1	VALVE MOUNT BRACKET	
5	150-2712	1	THRUST VALVE	
6	153-679	2	SP CONNECTOR (200-20090BK)	
7	514-096	2	BK CONNECTOR (200-200BK)	
8	154-388	1	CONNECTOR (16S-16045)	
9	154-289	1	CONNECTOR (16S-16090, XL)	
10	154-281	4	CONNECTOR (16S-160)	
11	154-290	2	UNION (160-160FX90)	
12	154-409	2	UNION RUN TEE (160FX-160-160)	
13	150-1794	1	HOSE (160FX-200FX90M-28-3000)	
14	153-663	1	Hose (160FX-20FL90S-36,5-3000)	
15	153-663	1	HOSE (160FX-20FL90S-36,5-3000)	
16	150-1793	1	HOSE (160FX-200FX90M-29-3000)	
17	150-1718	1	HYD LINE (-16)	
18	150-1719	1	HYD LINE (-16)	
19	159-036	2	SPLIT FLANGE (20SF, SET)	
20	115-731	2	ABRASION SLEEVE (2.38" X 34")	
21	117-678	2	ABRASION SLEEVE(1.75" X 29")	
22	514-422	2	CONNECTOR (200-200FX90)	
23	150-1705	1	HOSE (200FX90L-300"-3000)	
24	150-1704	1	HOSE (200FX90S-287"-3000)	
25	115-894	1	ABRASION SLEEVE (2.38" X 60")	
26	117-705	1	ABRASION SLEEVE (2.38" X 78")	

NOT SHOWN:

FOOTNOTES:

NOTE:

REFER TO O-RING CHART (800-301) IN BACK OF BOOK FOR REPLACEMENT OF O-RINGS.

INNER ROTATION CONTROL KIT

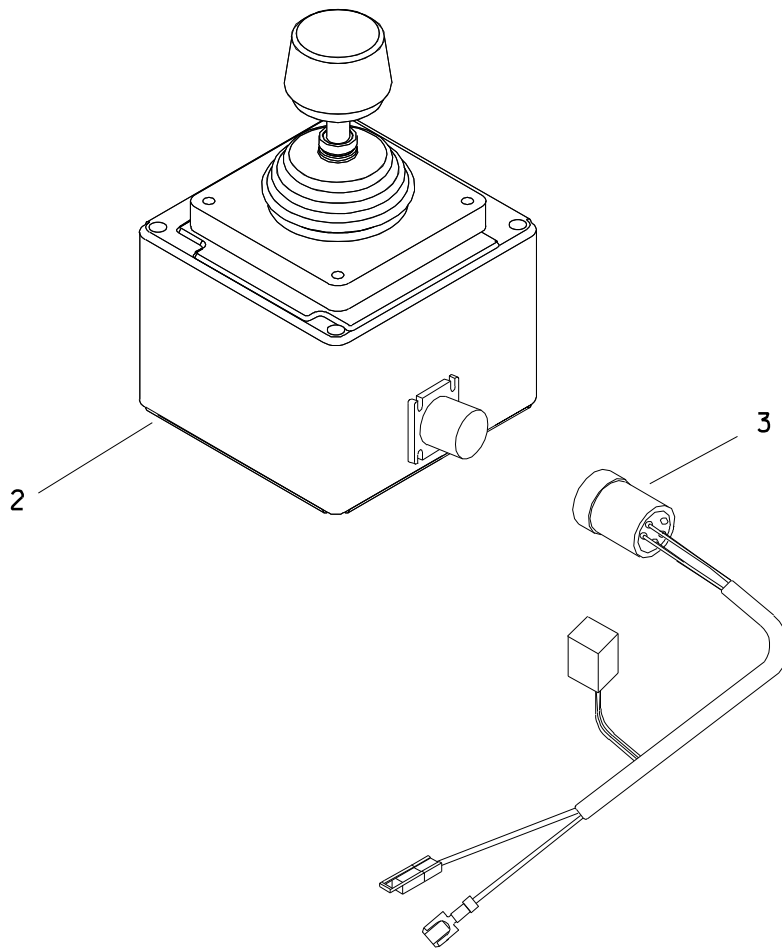

INNER ROTATION CONTROL KIT

REF NO.	PART NUMBER	QTY	DESCRIPTION	REMARKS
	101-155	-	INNER ROTATION CONTROL KIT	CONTAINS REF NO. 1-3
1.	051-346	1	INNER ROT JOYSTICK KIT INSTR	NOT SHOWN
2.	101-156	1	SPINDLE CONTROL BOX	
3.	213-099	1	INNER ROTATION HARNESS	
	217-710	-	MICRO RELAY (SPDT)	NOT SHOWN

FOOTNOTES

THRUST/TRACK DRIVE PUMP HYDRAULICS

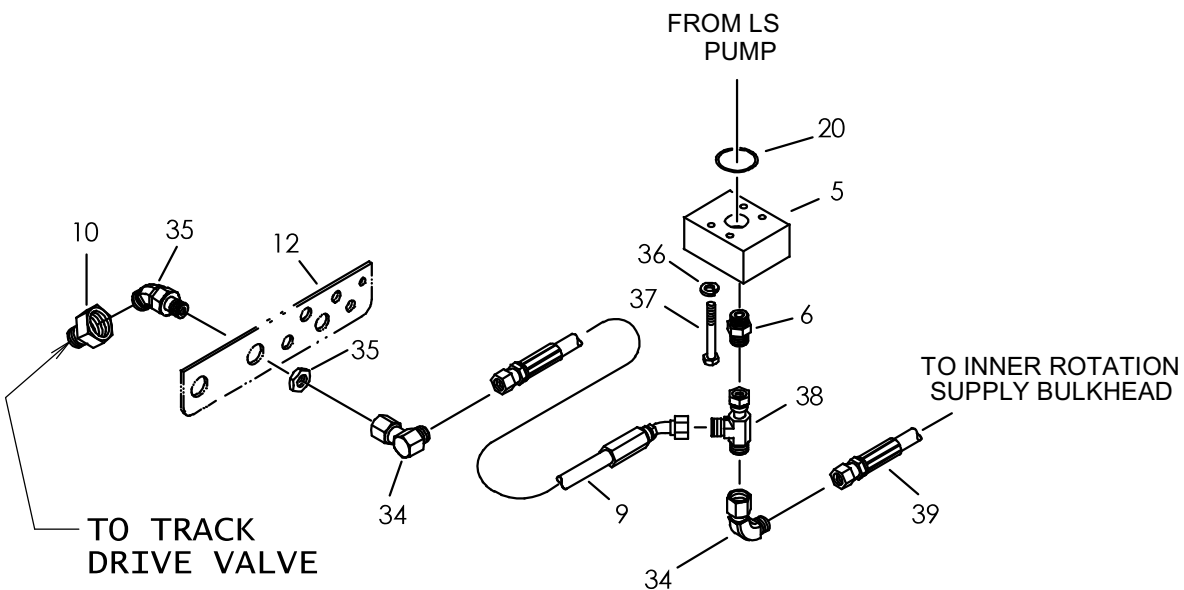
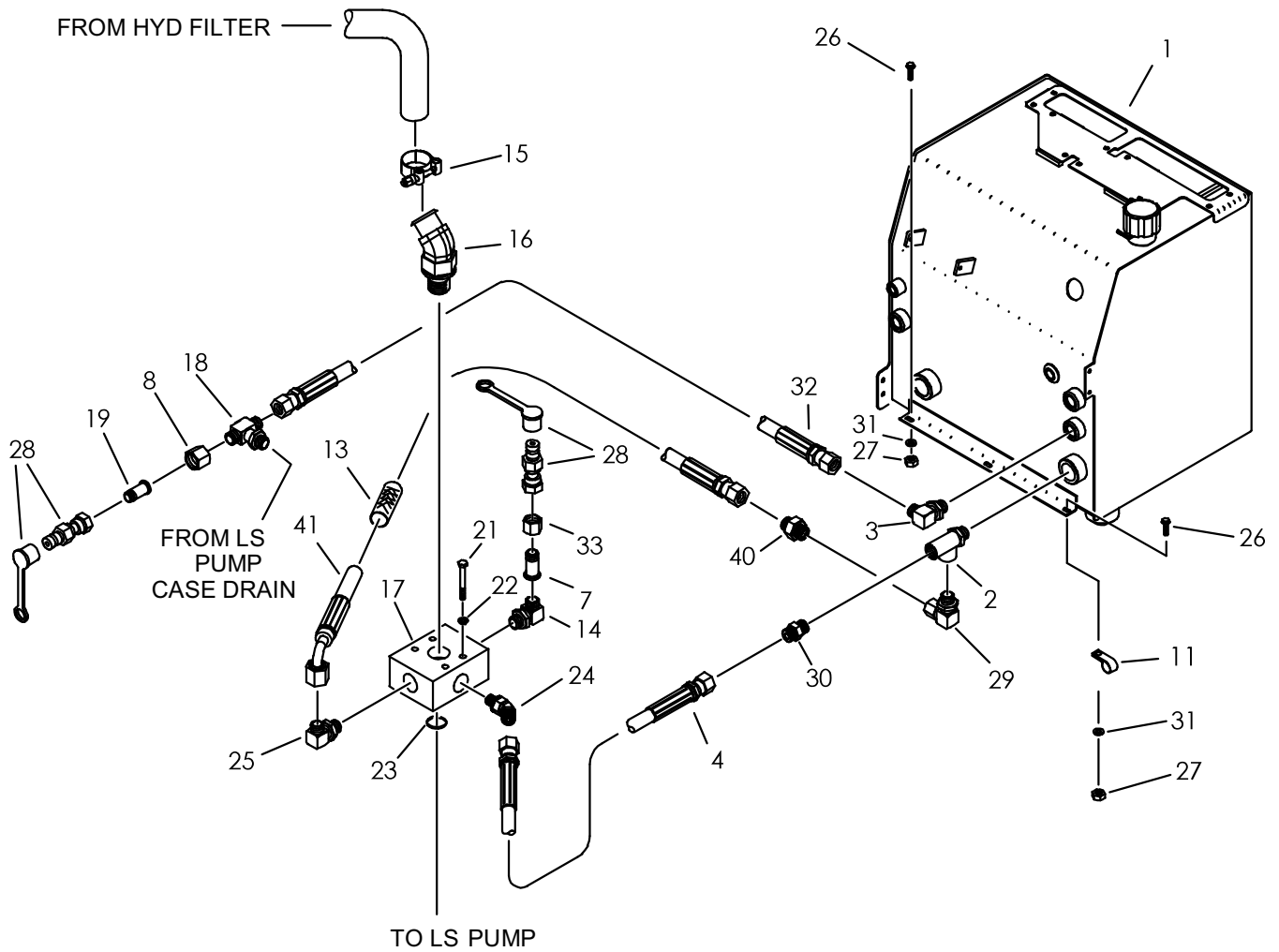

THRUST/TRACK DRIVE PUMP HYDRAULICS

REF NO.	PART NUMBER	QTY	DESCRIPTION	REMARKS
1.	350-614	-	HYDRAULIC RESERVOIR	
2.	153-899	1	RUN TEE (20S-16SF-16SF)	
3.	154-377	1	CONNECTOR (12S-16090)	
4.	157-498	1	HOSE (160FX-22"-212)	
5.	153-393	1	MANIFOLD BLOCK	
6.	514-097	1	CONNECTOR (20S-200)	
7.	154-249	1	REDUCER STEM (080)	
8.	154-340	1	REDUCER NUT (160F)	
9.	157-754	1	HOSE (200FX45-27"-3000, SPEC)	
10.	514-144	1	REDUCER (160-200)	
11.	110-333	1	BOLT-ON CLAMP (1")	
12.	350-740	-	BULKHEAD PLATE	
13.	117-296	1	ABRASION SLEEVE (2.07" X 30")	
14.	514-010	1	CONNECTOR (120-20S90)	
15.	318-890	-	T-BLT CLP BRIDG 1.875-2.188	
16.	153-370	-	S/O COUPLER (24S-24H45)	
17.	153-892	1	PUMP INLET MANIFOLD	
18.	154-347	1	BRANCH TEE (16S-160-160)	
19.	154-341	1	REDUCER STEM (080)	
20.	157-128	1	O-RING (225 D90)	
21.	105-110	4	BOLT (1/2-NC X 4-1/2")	
22.	105-070	4	LOCK WASHER (.500")	
23.	157-015	1	O-RING (232 D70)	
24.	154-371	1	CONNECTOR (12S-16045)	
25.	514-196	1	CONNECTOR (160-20S90)	
26.	106-381	6	FLG LK SCREW (M8-1.25 X 25MM)	
27.	106-561	6	LOCKNUT (M8-1.25, PRV TRQ, 10.9)	
28.	159-158	2	QDC ADAPTER (02-080FX)	
	159-148		DUST CAP (1/8")	
29.	153-908	1	UNION (16S-160FX90)	
30.	153-903	1	CHECK VALVE	
31.	105-118	6	WASHER (3/8")	
32.	157-755	1	HOSE (160FX-20"-212)	
33.	154-271	1	REDUCER NUT (120F)	
34.	514-422	2	CONNECTOR (200-200FX90)	
35.	153-395	1	BK CONNECTOR (200-20045)	
36.	105-385	4	LOCK WASHER (5/8")	
37.	105-943	4	BOLT (5/8-NC X 2-3/4")	
38.	514-142	1	UN RUN TEE (200FX-200-200)	
39.	157-753	1	HOSE (200FX-26"-3000, SPEC)	
40.	153-904	1	CHECK VALVE	
41.	153-938	1	HOSE (160FX90S-30"-200)	

NOT SHOWN:

FOOTNOTES:

NOTE:

REFER TO O-RING CHART (800-301) IN BACK OF THE BOOK FOR REPLACEMENT OF O-RINGS.

THRUST VALVE, JT

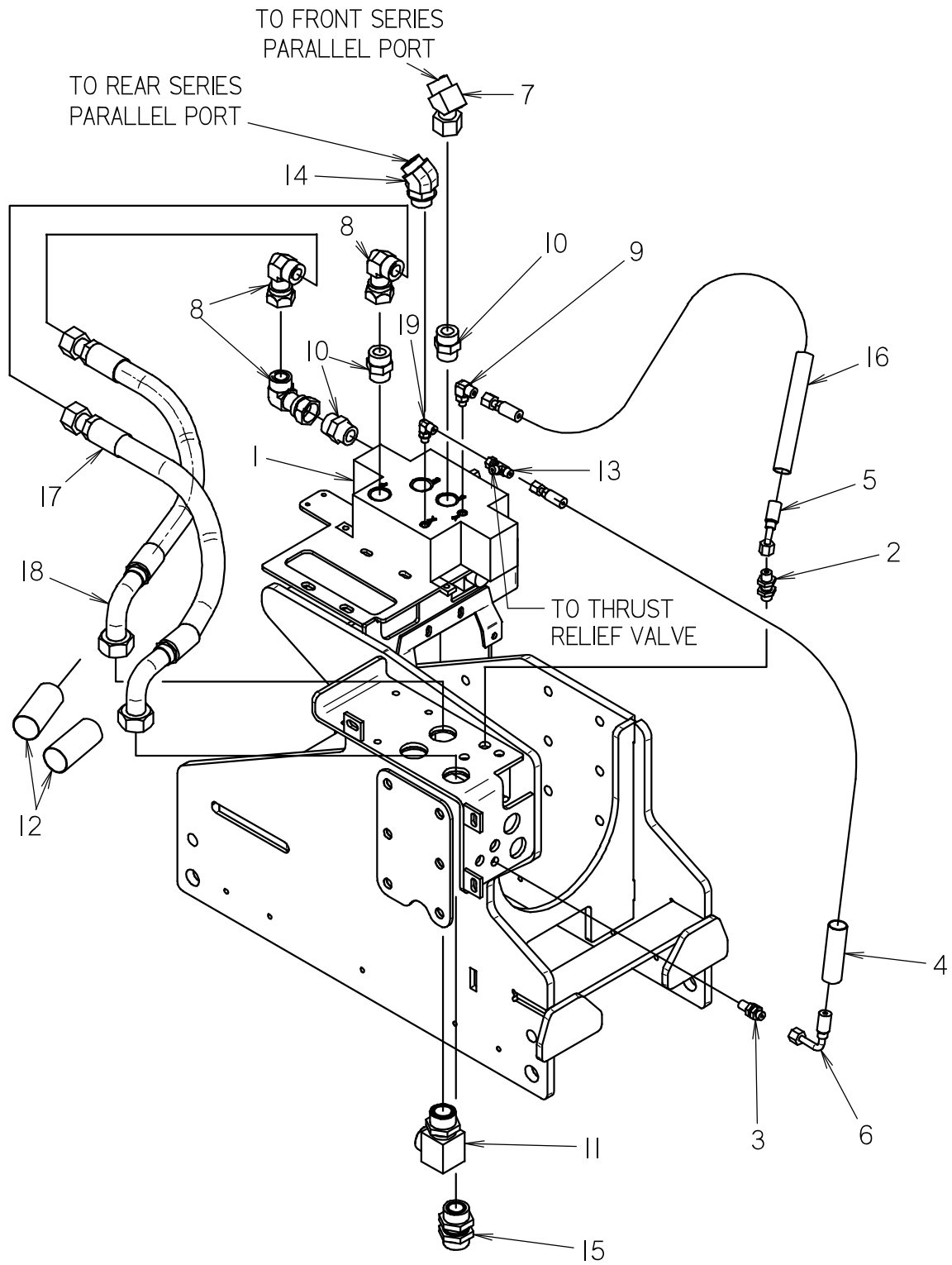

THRUST VALVE, JT

REF NO.	PART NUMBER	QTY	DESCRIPTION	REMARKS
1	I50-2712	1	THRUST VALVE	
2	514-I63	1	BK CONNECTOR I060-060BK)	
3	I54-275	1	BK CONNECTOR I040-040BK)	
4	I17-411	1	ABRASION SLEEVE (1.00" X 32")	
5	I54-887	1	HOSE(I060FX45-23"-3000)	
6	I50-I066	1	HOSE(I040FX90L-30"-3000)	
7	I53-249	1	CONNECTOR I160-I60FX45)	
8	I54-290	3	UNION (I160-I60FX90)	
9	514-049	1	CONNECTOR (04S-06090)	
10	I54-281	3	CONNECTOR (I16S-I60)	
11	I53-679	1	SP CONNECTOR (200-20090BK)	
12	I17-678	2	ABRASION SLEEVE(1.75" X 29")	
13	I54-265	1	UNION RUN TEE (040FX-040-040)	
14	I54-388	1	CONNECTOR (I16S-I6045)	
15	514-096	1	BK CONNECTOR (200-200BK)	
16	I17-993	1	ABRASION SLEEVE (1.00" X 23")	
17	I50-I794	1	HOSE (I160FX-200FX90M-28-3000)	
18	I50-I793	1	HOSE (I160FX-200FX90M-29-3000)	
19	I54-252	1	CONNECTOR (04S-04090)	

NOT SHOWN:

FOOTNOTES:

NOTE:

THRUST HYDRAULICS

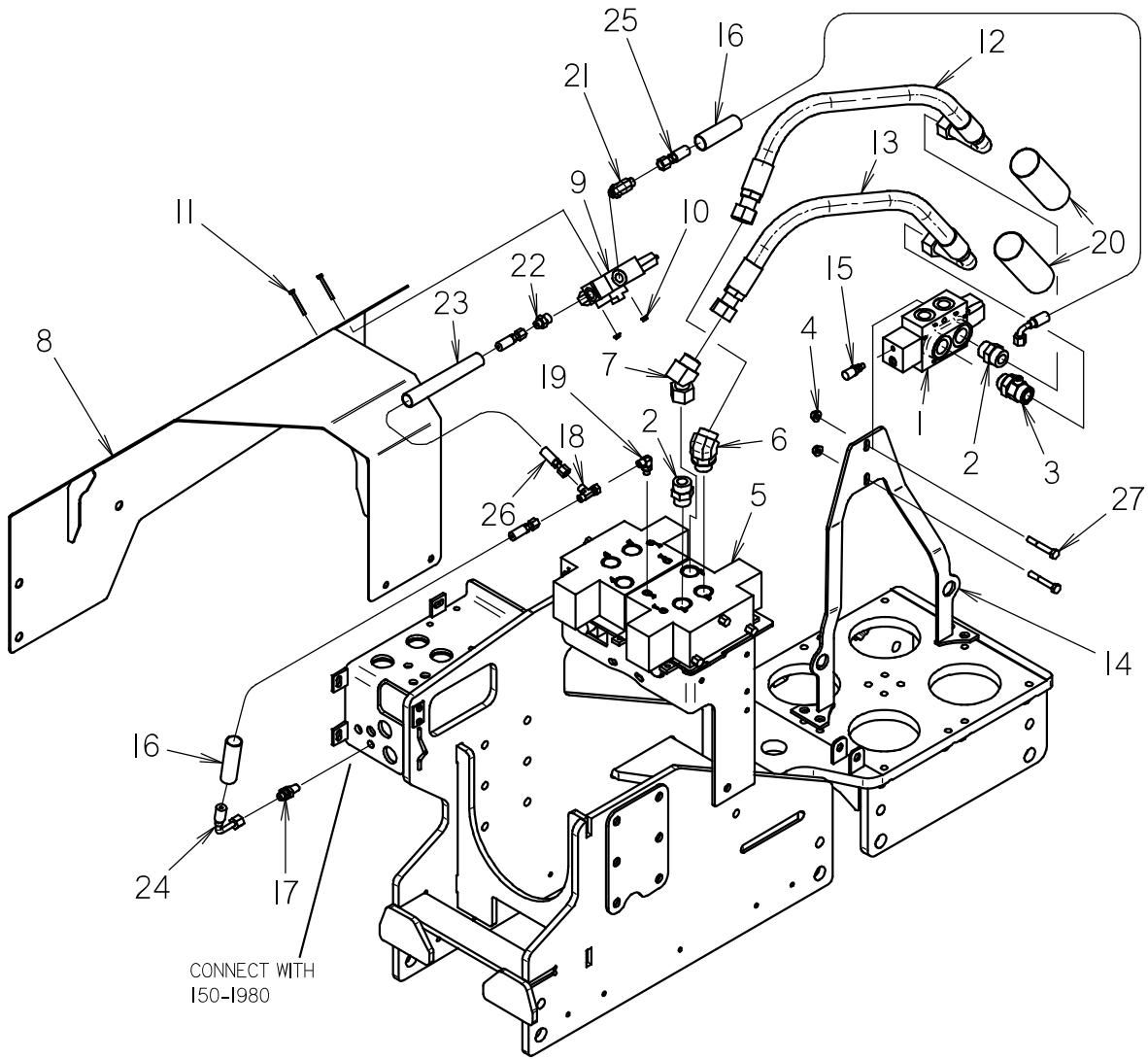

THRUST HYDRAULICS

REF NO.	PART NUMBER	QTY	DESCRIPTION	REMARKS
1	149-343	1	HYDRAULIC CONTROL VALVE	
2	154-281	2	CONNECTOR (16S-160)	
3	514-411	1	RUN TEE (16S-160-060)	
4	106-387	2	FLG LOCKNUT (M10-1.50)	
5	150-2712	1	THRUST VALVE	
6	154-388	1	CONNECTOR (16S-16045)	
7	153-249	1	CONNECTOR (160-160FX45)	
8	327-1077	1	CARRIAGE COVER	
9	153-328	1	HYDRAULIC VALVE	
10	106-385	2	FLG LOCKNUT (M6-1.00)	
11	107-025	2	SCREW (M6-1.00 X 50MM)	
12	150-1792	1	HOSE(160FX-160FX90L-31-3000)	
13	150-1791	1	HOSE(160FX-160FX90L-33-3000)	
14	327-1070	1	BRACKET	
15	163-101	1	BLEEDER VALVE	
16	117-411	2	ABRASION SLEEVE (1.00" X 32")	
17	154-275	1	BK CONNECTOR (040-040BK)	
18	154-265	1	UNION RUN TEE (040FX-040-040)	
19	154-252	1	CONNECTOR (04S-04090)	
20	115-731	2	ABRASION SLEEVE (2.38" X 34")	
21	154-227	1	CONNECTOR (060-08S90)	
22	154-261	1	CONNECTOR (040-08S)	
23	117-607	1	ABRASION SLEEVE (1.00" X 21")	
24	150-1066	1	HOSE(040FX90L-30"-3000)	
25	515-707	1	HOSE(060FX90-32"-3000)	
26	515-735	1	HOSE(040FX-22"-3000)	
27	106-332	2	SCREW (M10-1.50 X 70MM)	

NOT SHOWN:

FOOTNOTES:

NOTE:

THRUST DRIVE HYDRAULICS

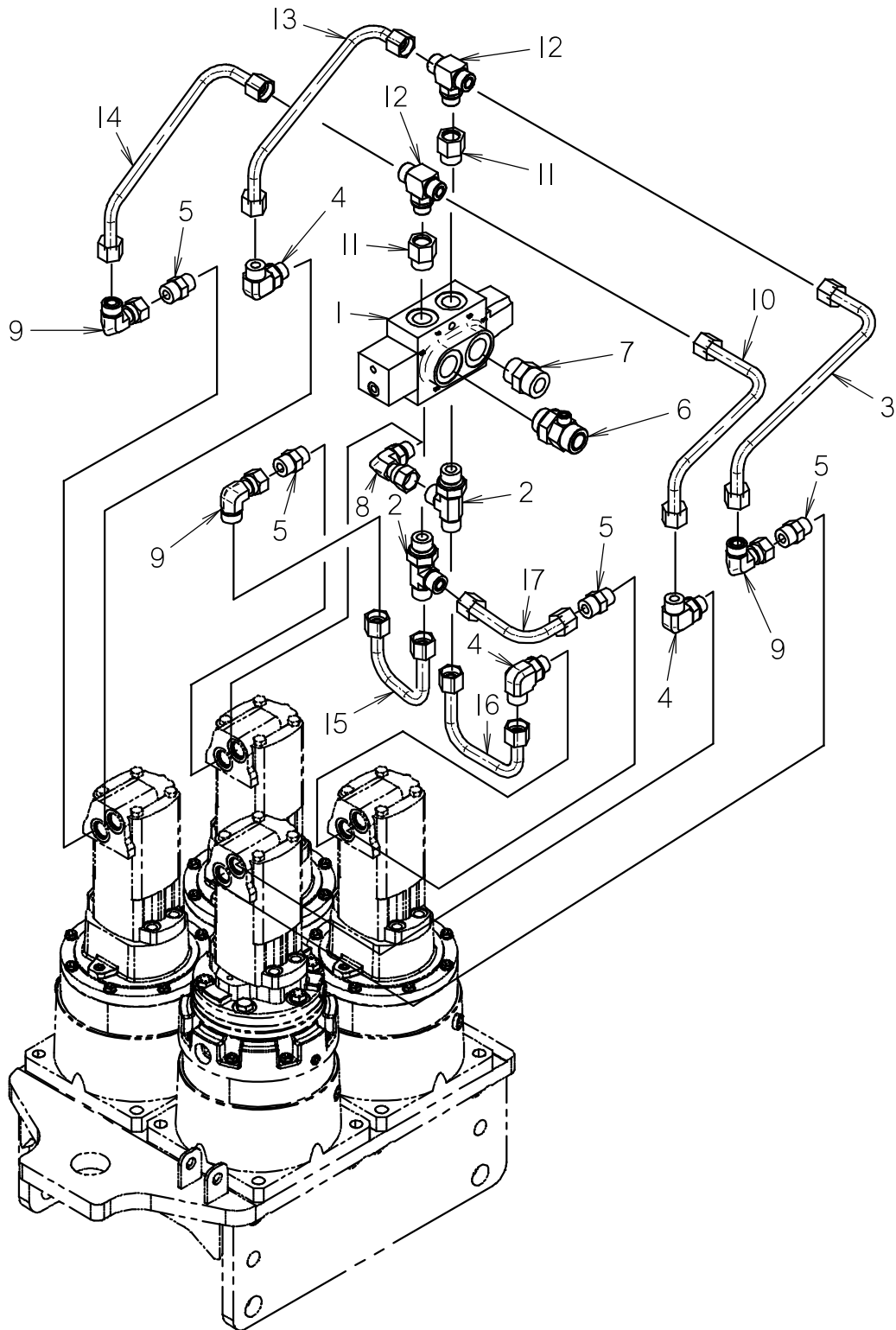

THRUST DRIVE HYDRAULICS

REF NO.	PART NUMBER	QTY	DESCRIPTION	REMARKS
1	149-343	1	HYDRAULIC CONTROL VALVE	
2	154-370	2	RUN TEE (12S-100-100)	
3	150-1716	1	HYDRAULIC LINE (-10)	
4	154-298	3	CONNECTOR (10S-10090)	
5	154-301	4	CONNECTOR (10S-100)	
6	514-411	1	RUN TEE (16S-160-060)	
7	154-281	1	CONNECTOR (16S-160)	
8	154-372	1	UNION (10S-100FX90)	
9	154-315	3	UNION (100-100FX90)	
10	150-1717	1	HYDRAULIC LINE (-10)	
11	510-017	2	REDUCER (12S-10SF)	
12	154-318	2	BRANCH TEE (10S-100-100)	
13	150-1715	1	HYDRAULIC LINE (-10)	
14	150-1714	1	HYDRAULIC LINE (-10)	
15	150-1695	1	HYDRAULIC LINE (-10)	
16	150-1713	1	HYDRAULIC LINE (-10)	
17	150-1712	1	HYDRAULIC LINE (-10)	

NOT SHOWN:

FOOTNOTES:

NOTE:

REFER TO O-RING CHART (800-301) IN BACK OF BOOK FOR REPLACEMENT OF O-RINGS.

FLUID MOTOR HYDRAULICS

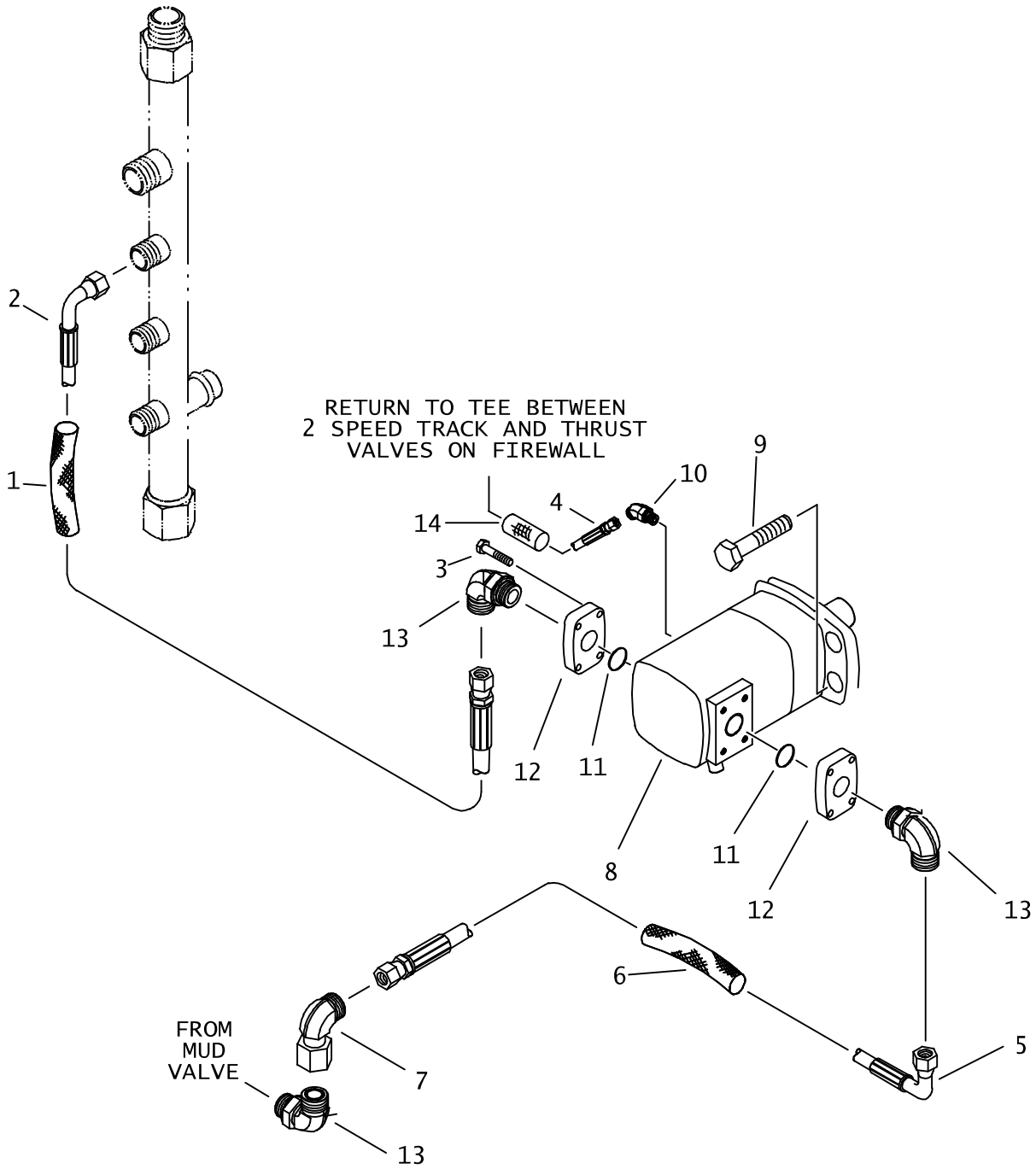

FLUID MOTOR HYDRAULICS

REF NO.	PART NUMBER	QTY	DESCRIPTION	REMARKS
1.	117-097	1	ABRASION SLEEVE (2.07" X 80")	
2.	157-284	1	HOSE (160FX90S-84"-3000)	
3.	105-918	8	BOLT (7/16-NC X 1-1/2", SOC)	
4.	154-789	1	HOSE (060FX-102"-3000)	
5.	153-432	1	HOSE (160FX90S-64"-3000)	
6.	117-179	1	ABRASION SLEEVE (2.07" X 62")	
7.	154-290	1	UNION (160-160FX90)	
8.	149-395	1	HYDRAULIC MOTOR	SEE FOOTNOTE 2
	158-013	1	HYDRAULIC MOTOR	SEE FOOTNOTE 1
	500-1532	AR	SEAL REPAIR KIT	
9.	105-282	4	BOLT (1/2-NC X 1-1/4", SOC)	
10.	154-224	1	CONNECTOR (06S-06045)	
11.	157-078	2	O-RING (222 D90)	
12.	149-084	2	HEAD FLANGE (20FL-16SF)	
13.	154-287	3	CONNECTOR (16S-16090)	
14.	117-213	1	ABRASION SLEEVE (1.00" X 96")	

NOT SHOWN:

FOOTNOTES:

1. USED WITH 158-434 (70 GPM MUD PUMP)
2. USED WITH 149-396 (120 GPM MUD PUMP)

NOTE

REFER TO O-RING CHART (800-301) IN BACK OF THE BOOK FOR REPLACEMENT OF O-RINGS.

NOTE:

TRACK DRIVE HYDRAULICS

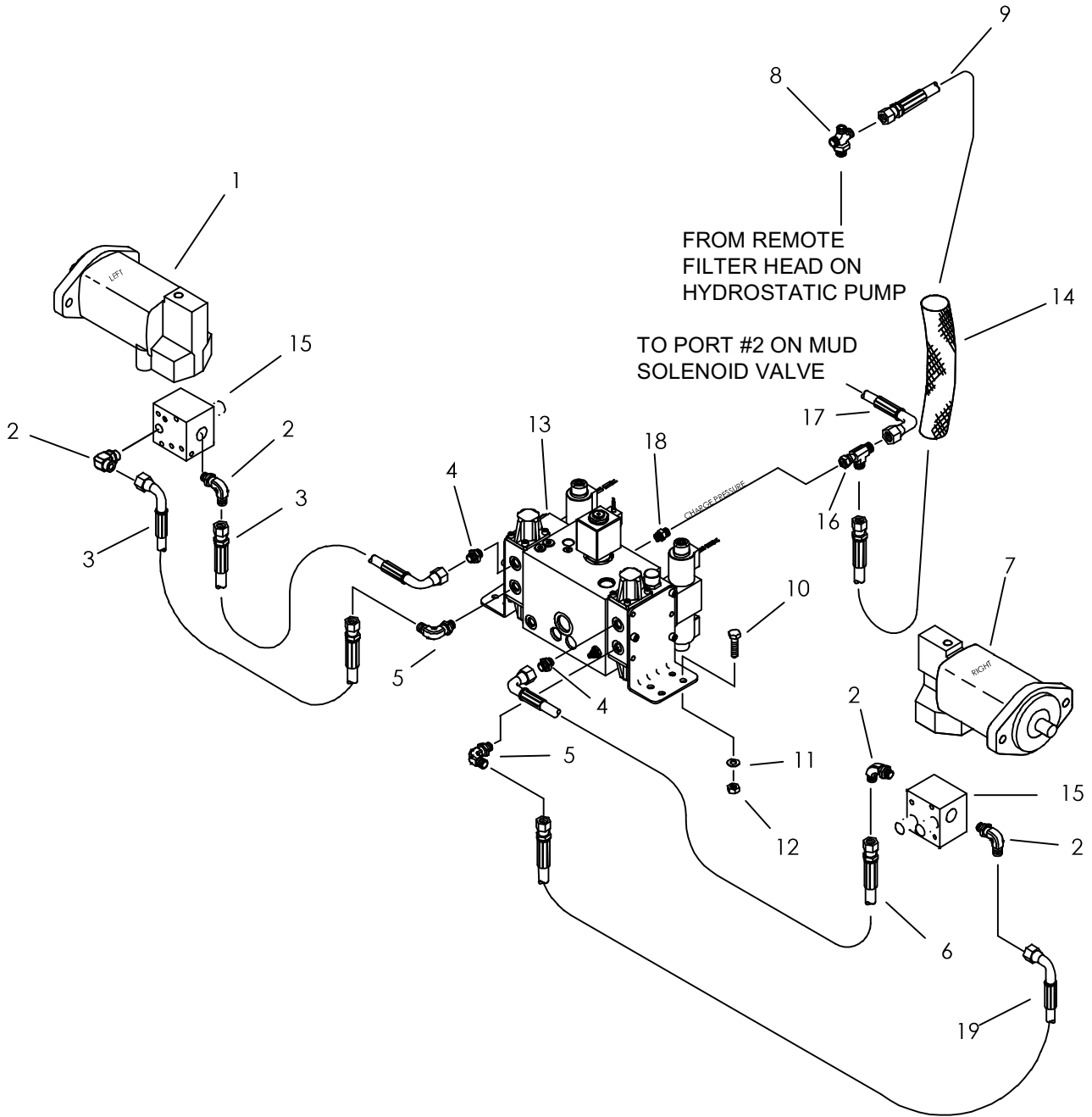

TRACK DRIVE HYDRAULICS

REF NO.	PART NUMBER	QTY	DESCRIPTION	REMARKS
1.	153-593	1	HYDRAULIC MOTOR	LEFT TRACK
2.	154-270	4	CONNECTOR (12S-12090)	
3.	153-758	2	HOSE (120FX90S-14"-3000)	
4.	154-247	2	CONNECTOR (10S-120)	
5.	154-273	2	CONNECTOR (10S-12090)	
6.	153-759	1	HOSE (120FX90M-16"-3000)	
7.	153-592	1	HYDRAULIC MOTOR	RIGHT TRACK, USE SEAL KIT 500-752
8.	149-847	-	CROSS (06S-060-060-080)	
9.	154-757	1	HOSE (060FX-86"-3000)	
10.	106-079	4	SCREW (M10-1.50 X 30mm)	
11.	106-396	4	WASHER (M10, HARDENED)	
12.	105-894	4	LOCKNUT (M10-1.50, PRV TRQ, 10.9)	
13.	153-639	1	HYD CONTROL VALVE	SEE FOOTNOTE 1
14.	117-398	1	ABRASION SLEEVE (1.00" X 86")	
15.	153-767	2	COUNTERBALANCE MANIFOLD	
16.	154-344	1	UN RUN TEE (060FX-060-060)	
17.	515-583	-	HOSE (060FX90-12"-3000)	
18.	156-174	1	CONNECTOR (06S-060)	BACK PORT (NOT SHOWN)
19.	153-928	1	HOSE (120FX90L-16"-3000)	

NOT SHOWN:

FOOTNOTES:

1. 153-639 HYD CONTROL VALVE IS SUPERSEDED BY 150-1815 HYDRAULIC CONTROL VALVE

NOTE:

REFER TO O-RING CHART (800-301) IN BACK OF THE BOOK FOR REPLACEMENT OF O-RINGS.

TRACK CASE DRAIN HYDRAULICS

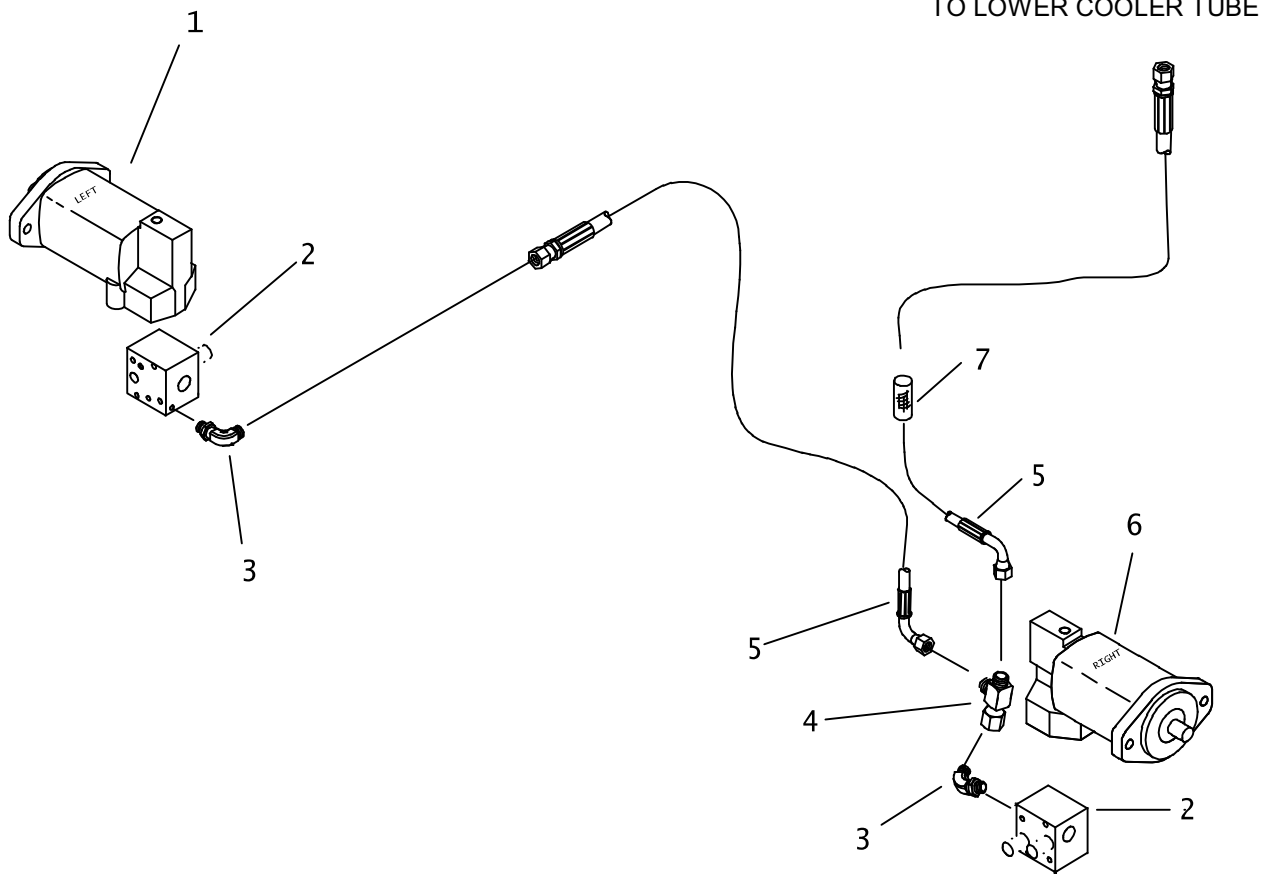

TRACK CASE DRAIN HYDRAULICS

REF NO.	PART NUMBER	QTY	DESCRIPTION	REMARKS
1.	153-593	-	HYDRAULIC MOTOR	
2.	153-767	-	COUNTERBALANCE MANIFOLD	
3.	154-252	2	CONNECTOR (04S-04090)	
4.	154-265	1	UN RUN TEE (040FX-040-040)	
5.	154-728	2	HOSE (040FX90-36"-3000)	
6.	153-592	-	HYDRAULIC MOTOR	USE SEAL KIT 500-752
7.	117-718	1	ABRASION SLEEVE (1.00" X 36")	

NOT SHOWN:

FOOTNOTES:

NOTE:

REFER TO O-RING CHART (800-301) IN BACK OF THE BOOK FOR REPLACEMENT OF O-RINGS.

WRENCH HYDRAULICS

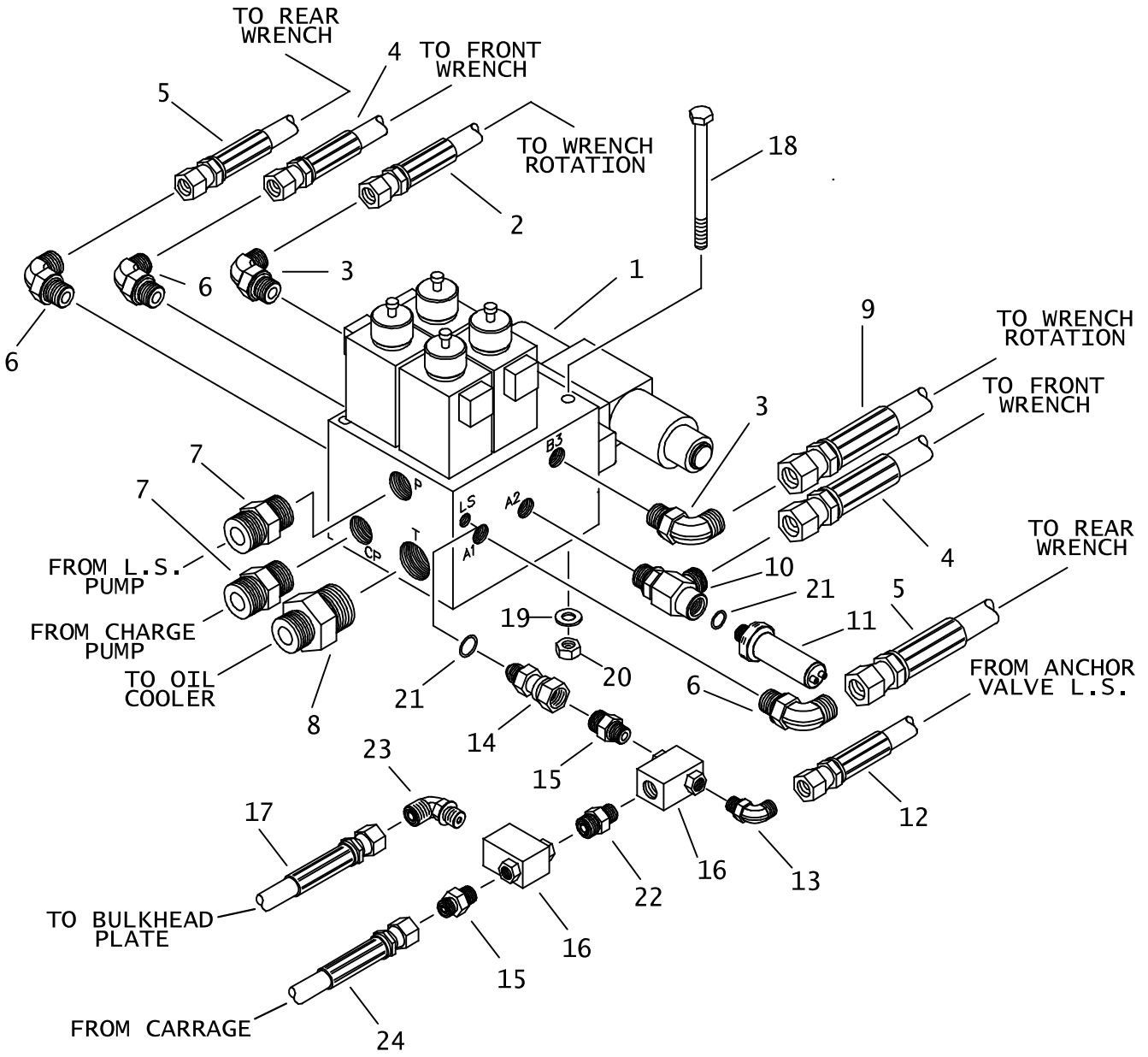

WRENCH HYDRAULICS

REF NO.	PART NUMBER	QTY	DESCRIPTION	REMARKS
1.	153-410	1	HYDRAULIC VALVE	
	499-309	-	SOLENOID	
	499-311	-	SOLENOID CARTRIDGE	
	499-312	-	SOLENOID COIL	
	501-872	-	SHUTTLE VALVE	
	499-313	-	CHECK VALVE	
	191-103	-	SEAL REPAIR KIT	
	191-104	-	SEAL REPAIR KIT	
	500-703	-	SEAL REPAIR KIT	
2.	154-797	-	HOSE (060FX-48"-3000)	
3.	154-227	2	CONNECTOR (060-08S90)	
4.	154-884	-	HOSE (080FX90-60"-3000)	
5.	515-214	-	HOSE (080FX45-80"-3000)	
6.	154-235	3	CONNECTOR (08S-08090)	
7.	154-269	2	CONNECTOR (12S-120)	
8.	154-367	1	CONNECTOR (120-16S)	
9.	154-996	-	HOSE (060FX-58"-3000)	
10.	149-572	1	CONNECTOR (08S-08090-06SF)	
11.	215-1227	1	PRESSURE SWITCH (500PSI)	
12.	515-410	-	HOSE (060FX45-118"-3000)	
13.	154-342	-	CONNECTOR (06S-06090)	
14.	514-409	1	UNION (06J-060FX)	
15.	156-067	-	CONNECTOR (06S-060, ORF .031")	
16.	158-600	-	HYD SHUTTLE VALVE	
17.	154-816	-	HOSE (060FX-120"-3000)	
18.	107-420	3	SCREW (M10-1.50 X 140MM)	
19.	106-390	3	WASHER (M10)	
20.	105-894	3	LOCKNUT(M10-1.50, PRV TRQ, 10.9)	
21.	155-705	2	O-RING (906 D90)	
22.	155-153	-	CONNECTOR (06S-06S)	
23.	154-342	-	CONNECTOR (06S-06090)	
24.	157-288	-	HOSE (060FX45-234"-3000)	

NOT SHOWN:

FOOTNOTES:

NOTE:

REFER TO O-RING CHART (800-301) IN BACK OF THE BOOK FOR REPLACEMENT OF O-RINGS.

FRONT WRENCH HYDRAULICS

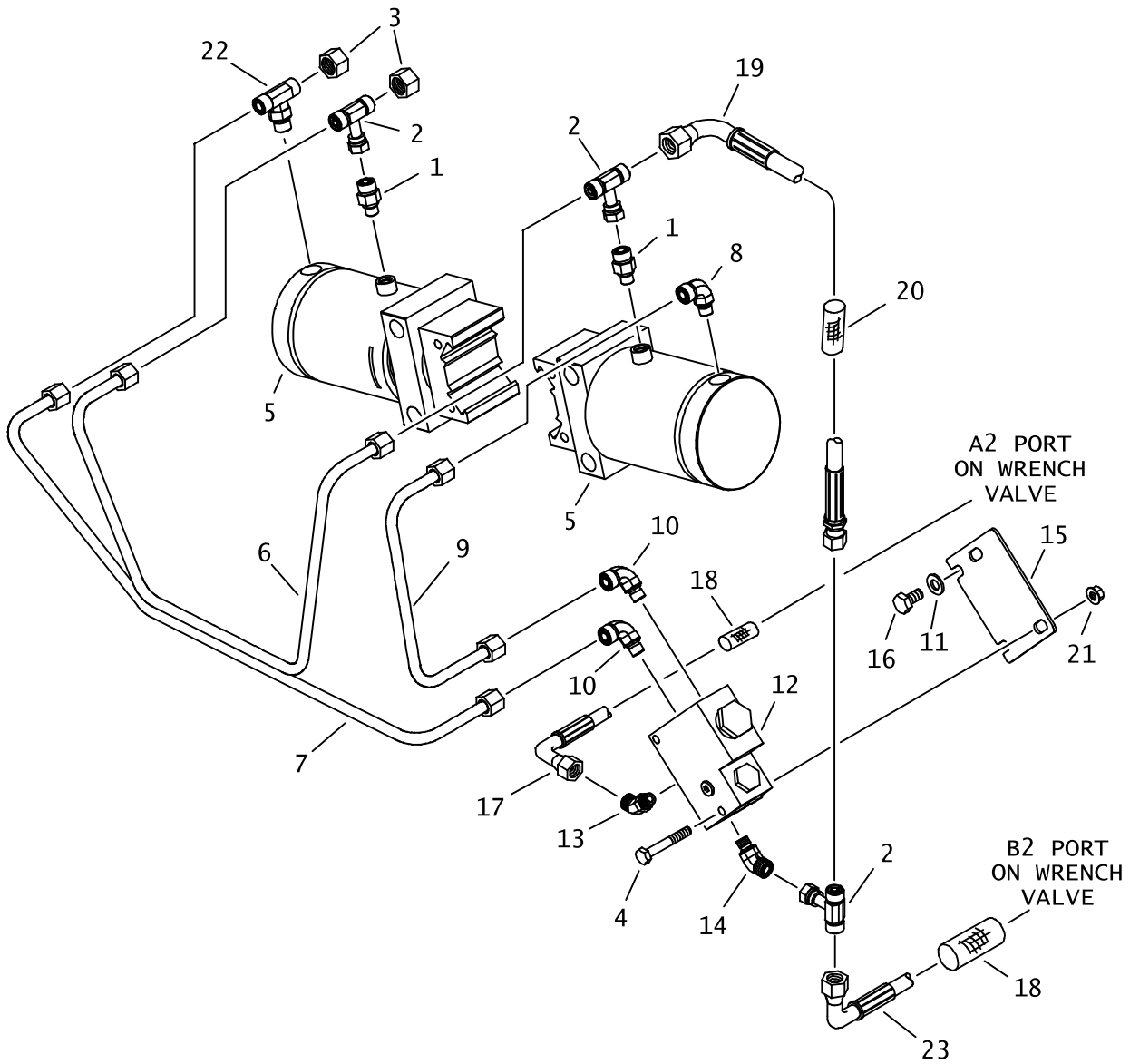

FRONT WRENCH HYDRAULICS

REF NO.	PART NUMBER	QTY	DESCRIPTION	REMARKS
1.	154-246	2	CONNECTOR (06S-080)	
2.	154-257	3	UN BR TEE (080FX-080-080)	
3.	154-327	2	CAP (080F)	
4.	106-142	2	SCREW (M10-1.50 X 65MM)	
5.	151-212	2	CYLINDER ASSEMBLY	4.50" X 2.25" X 2.75"
6.	153-649	1	HYD LINE	
7.	153-650	1	HYDRAULIC LINE (08)	
8.	154-253	1	CONNECTOR (06S-08090)	
9.	153-647	1	HYDRAULIC LINE (-08)	
10.	154-235	2	CONNECTOR (08S-08090)	
11.	106-397	2	WASHER (M12, HARDENED)	
12.	149-791	1	HYDRAULIC CONTROL VALVE	USE SERVICE PARTS: 500-2041 SEAL KIT & 500-2042 SEAL
13.	154-264	1	CONNECTOR (080-10S45)	
14.	154-283	1	CONNECTOR (06S-08045)	
15.	310-911	1	PLATE	
16.	107-521	2	SCREW (M12-1.75 X 20MM)	
17.	159-850	1	HOSE (080FX90S-63"-3000)	
18.	117-392	2	ABRASION SLEEVE (1.25" X 60")	
19.	154-750	1	HOSE (080FX90-28"-3000)	
20.	117-396	1	ABRASION SLEEVE (1.25" X 28")	
21.	107-661	2	FLG LKNUT (M10-1.50, PRV TRQ)	
22.	153-728	1	TEE (06S-080-080)	
23.	154-884	1	HOSE (080FX90-60"-3000)	

NOT SHOWN:

FOOTNOTES:

NOTE:

REFER TO O-RING CHART (800-301) IN BACK OF THE BOOK FOR REPLACEMENT OF O-RINGS.

REAR WRENCH HYDRAULICS

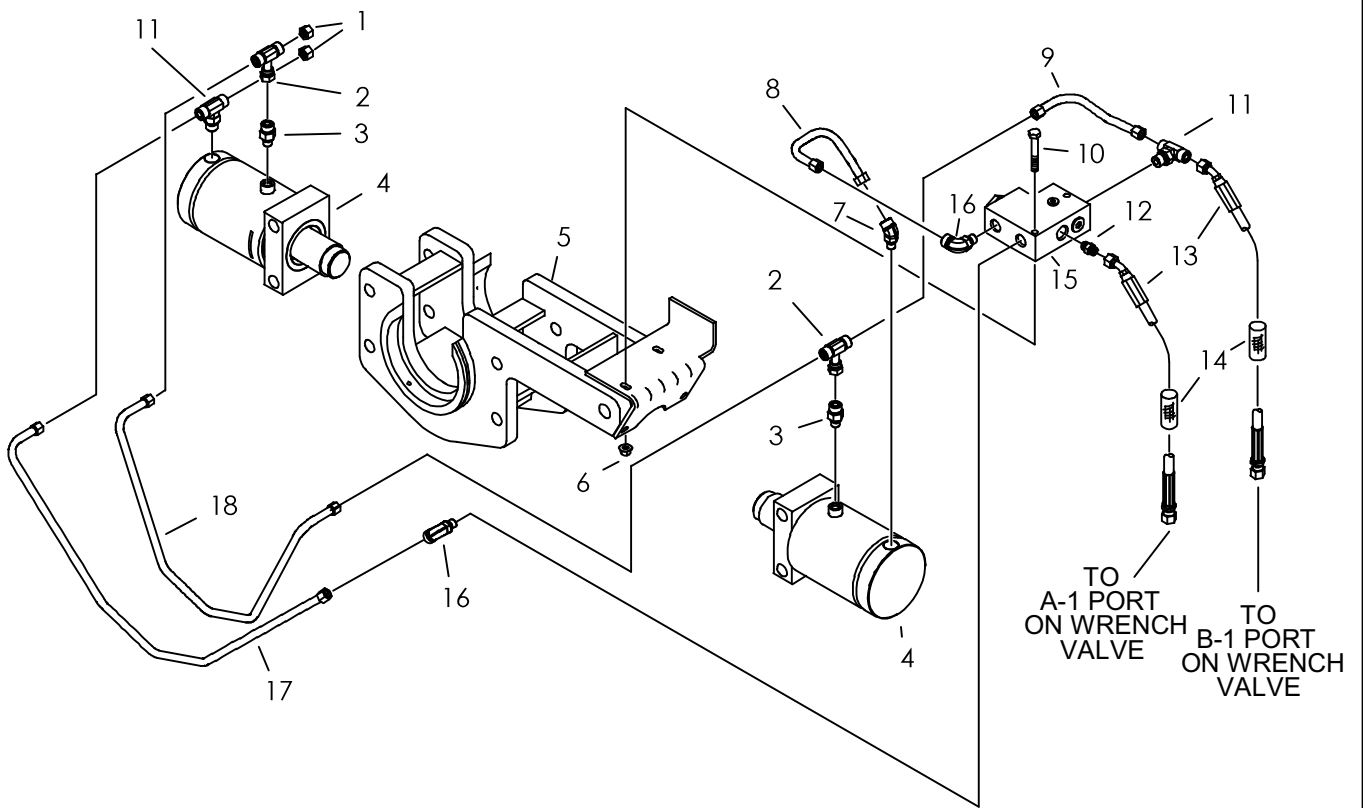

REAR WRENCH HYDRAULICS

REF NO.	PART NUMBER	QTY	DESCRIPTION	REMARKS
1.	154-327	2	CAP (080F)	
2.	154-257	2	UN BR TEE (080FX-080-080)	
3.	154-246	2	CONNECTOR (06S-080)	
4.	151-212	-	CYLINDER ASSEMBLY	
5.	313-717	-	ROTATION CLAMP	
6.	107-661	2	FLG LKNUT (M10-1.50, PRV TRQ)	
7.	154-283	1	CONNECTOR (06S-08045)	
8.	153-726	1	HYDRAULIC LINE (-08)	
9.	153-648	1	HYDRAULIC LINE (-08)	
10.	106-332	2	SCREW (M10-1.50 X 70MM)	
11.	153-728	2	TEE (06S-080-080)	
12.	154-279	1	CONNECTOR (080-10S)	
13.	515-214	2	HOSE (080FX45-80"-3000)	
14.	117-556	2	ABRASION SLEEVE (1.25" X 80")	
15.	149-791	1	HYDRAULIC CONTROL VALVE	USE SERVICE PARTS: 500-2041 SEAL KIT & 500-2042 SEAL
16.	154-235	2	CONNECTOR (08S-08090)	
17.	153-651	1	HYDRAULIC LINE (-08)	
18.	153-652	1	HYDRAULIC LINE (-08)	

NOT SHOWN:

FOOTNOTES:

NOTE:

REFER TO O-RING CHART (800-301) IN BACK OF THE BOOK FOR REPLACEMENT OF O-RINGS.

WRENCH ROTATE HYDRAULICS

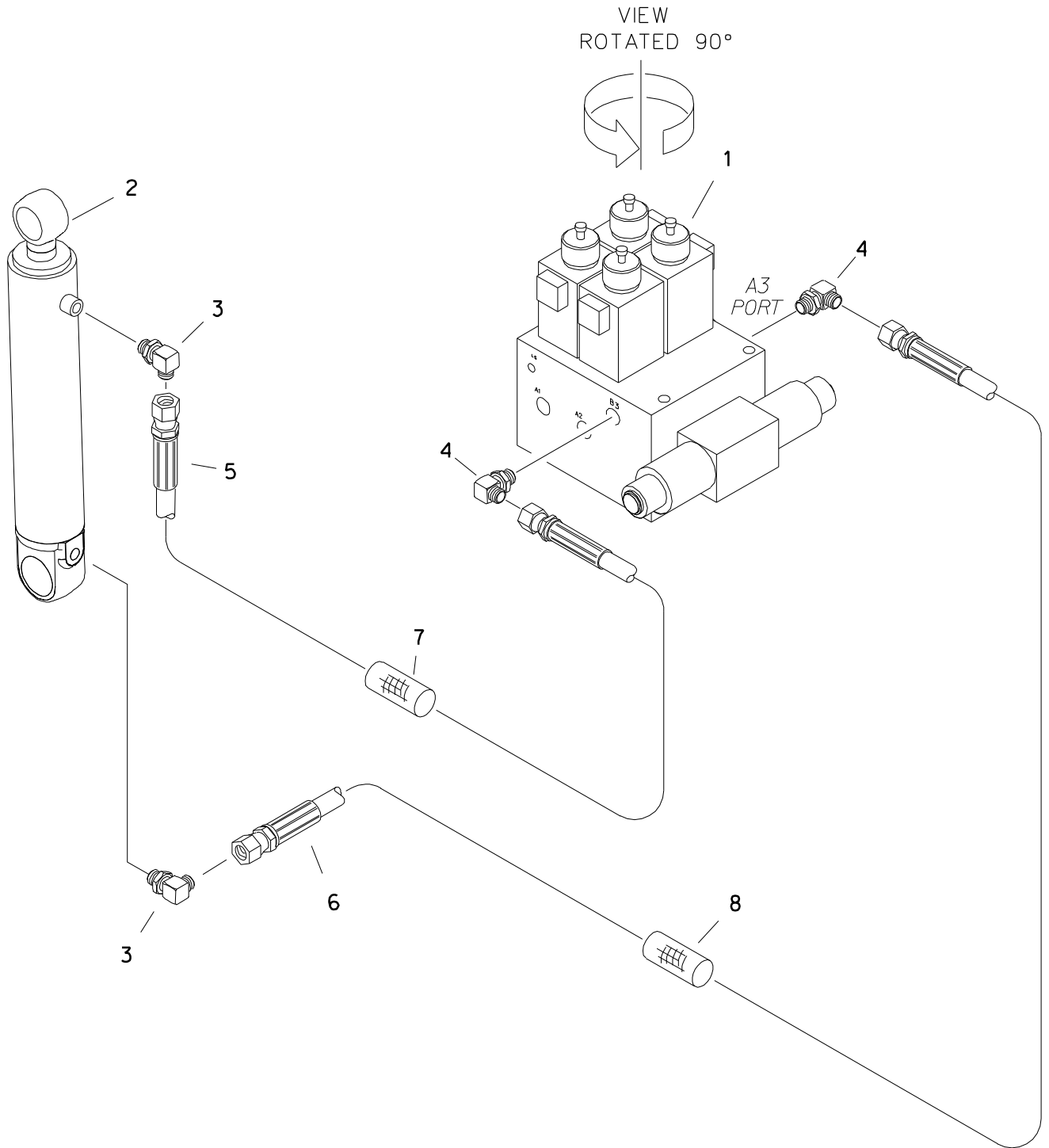

WRENCH ROTATE HYDRAULICS

REF NO.	PART NUMBER	QTY	DESCRIPTION	REMARKS
1.	153-410	-	HYDRAULIC VALVE	
2.	151-031	-	CYL (2.0" X 1.0" X 8.0")	
3.	514-049	2	CONNECTOR (04S-06090)	
4.	154-227	-	CONNECTOR (060-08S90)	
5.	154-996	1	HOSE (060FX-58"-3000)	
6.	154-797	1	HOSE (060FX-48"-3000)	
7.	117-326	1	ABRASION SLEEVE (1.00" X 58")	
8.	117-416	1	ABRASION SLEEVE (1.00" X 50")	

FOOTNOTES

NOTES

REFER TO O-RING CHART (800-301) IN BACK OF THE BOOK FOR REPLACEMENT OF O-RINGS.

ANCHOR SUPPLY HYDRAULICS

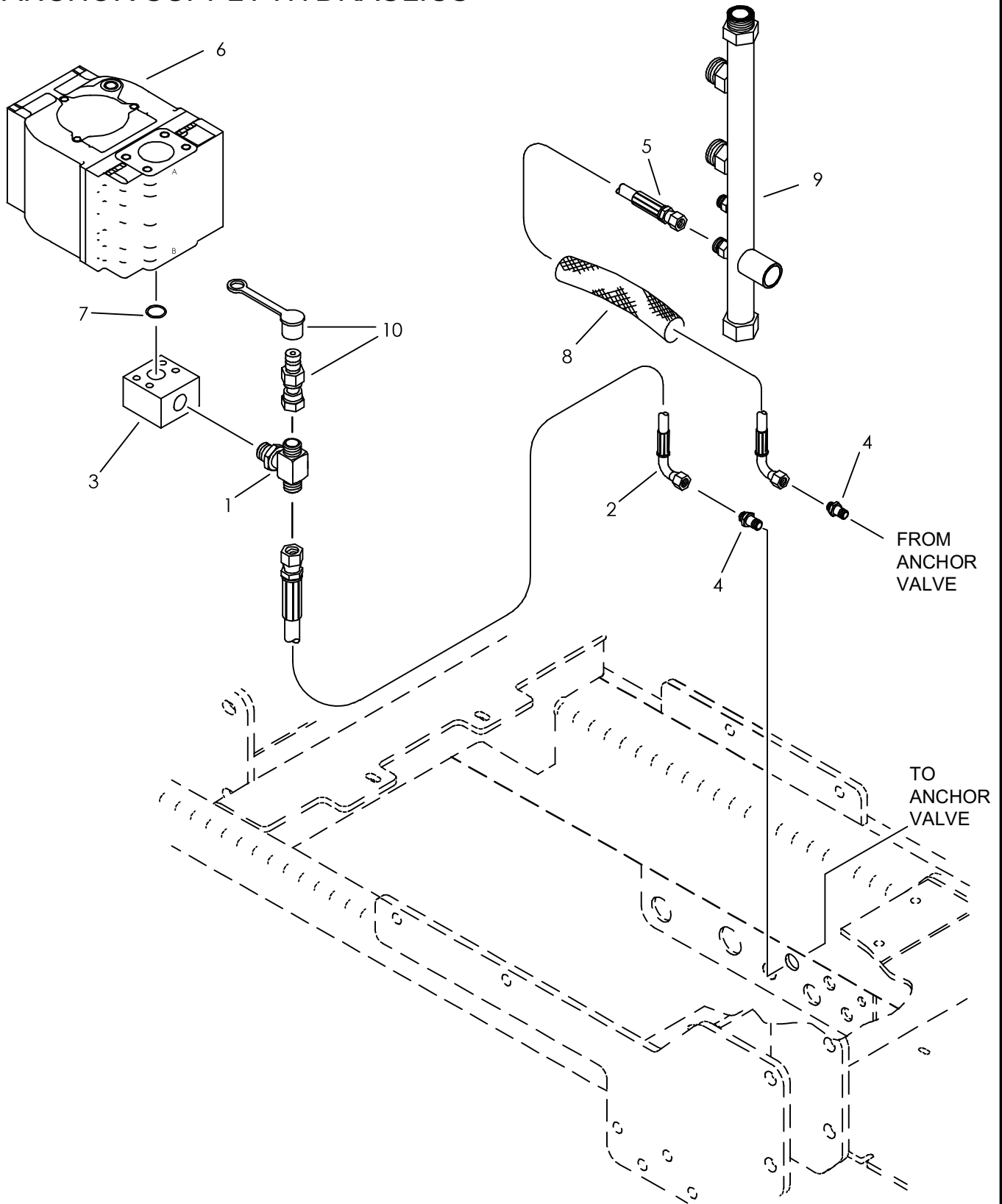

ANCHOR SUPPLY HYDRAULICS

REF NO.	PART NUMBER	QTY	DESCRIPTION	REMARKS
1.	154-318	1	BRANCH TEE (10S-100-100)	
2.	515-454	1	HOSE (100FX90L-20"-3000)	
3.	153-393	1	MANIFOLD BLOCK	
4.	154-309	2	BK CONNECTOR (100-100BK)	
5.	515-690	1	HOSE (100FX90L-58"-3000)	
6.	150-2180	-	HYDRAULIC PUMP LS	
	190-1371	-	PUMP SEAL KIT	
7.	157-128	-	O-RING (225 D90)	
8.	115-903	1	ABRASION SLEEVE (1.59" x 50")	
9.	153-389	-	COOLER BY-PASS	
10.	159-159	1	QDC ADAPTER (02-100FX)	
	159-148	1	DUST CAP (1/8")	

NOT SHOWN:

FOOTNOTES:

NOTE:

REFER TO O-RING CHART (800-301) IN BACK OF THE BOOK FOR REPLACEMENT OF O-RINGS.

ANCHOR VALE PRESSURE & RETURN HYDRAULICS

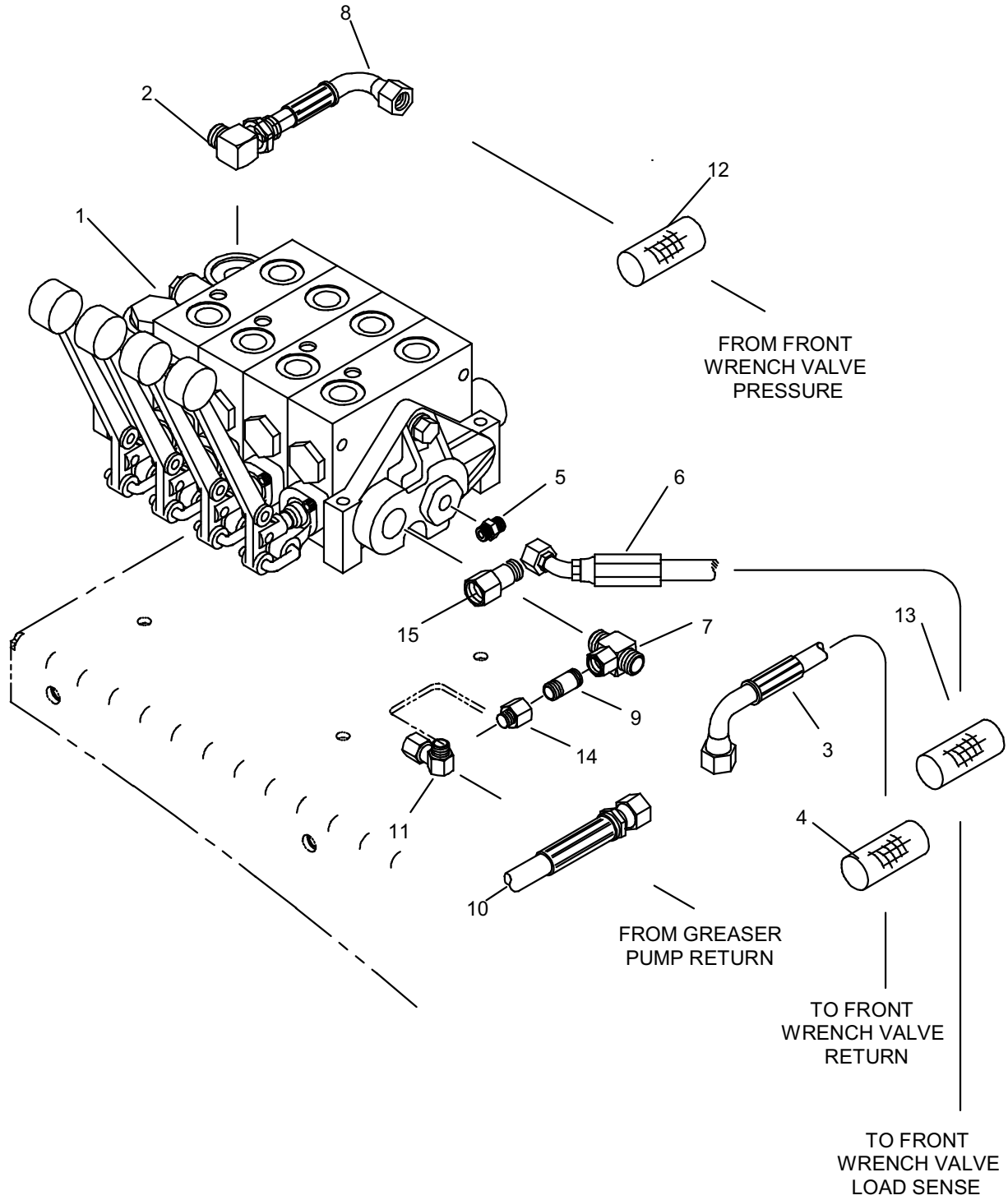

ANCHOR VALE PRESSURE & RETURN HYDRAULICS

REF NO.	PART NUMBER	QTY	DESCRIPTION	REMARKS
1.	158-064	1	HYD CONTROL VALVE (4-SPOOL)	
2.	154-300	1	CONNECTOR (100-12S90)	
3.	515-670	1	HOSE (100FX90-85"-3000)	
4.	115-817	1	ABRASION SLEEVE (1.59" X 84")	
5.	154-411	1	CONNECTOR (04S-060)	
6.	515-410	1	HOSE (060FX45-118"-3000)	
7.	154-458	1	UNION RUN TEE (06SFS-10S-100)	
8.	515-618	1	HOSE (100FX90-95"-3000)	
9.	159-381	1	CHECK VALVE (06S-060)	
10.	149-827	1	HOSE (040FX90S-24"-3000)	
11.	154-255	1	UNION (040-040FX90)	
12.	116-787	1	ABRASION SLEEVE (1.59" X 95")	
13.	117-212	1	ABRASION SLEEVE (1.25" X 118")	
14.	154-373	1	REDUCER (040-060F)	
15.	510-017	1	REDUCER (12S-10SF)	

NOT SHOWN:

FOOTNOTES:

NOTE:

REFER TO O-RING CHART (800-301) IN BACK OF THE BOOK FOR REPLACEMENT OF O-RINGS.

RIGHT ANCHOR MOTOR HYDRAULICS

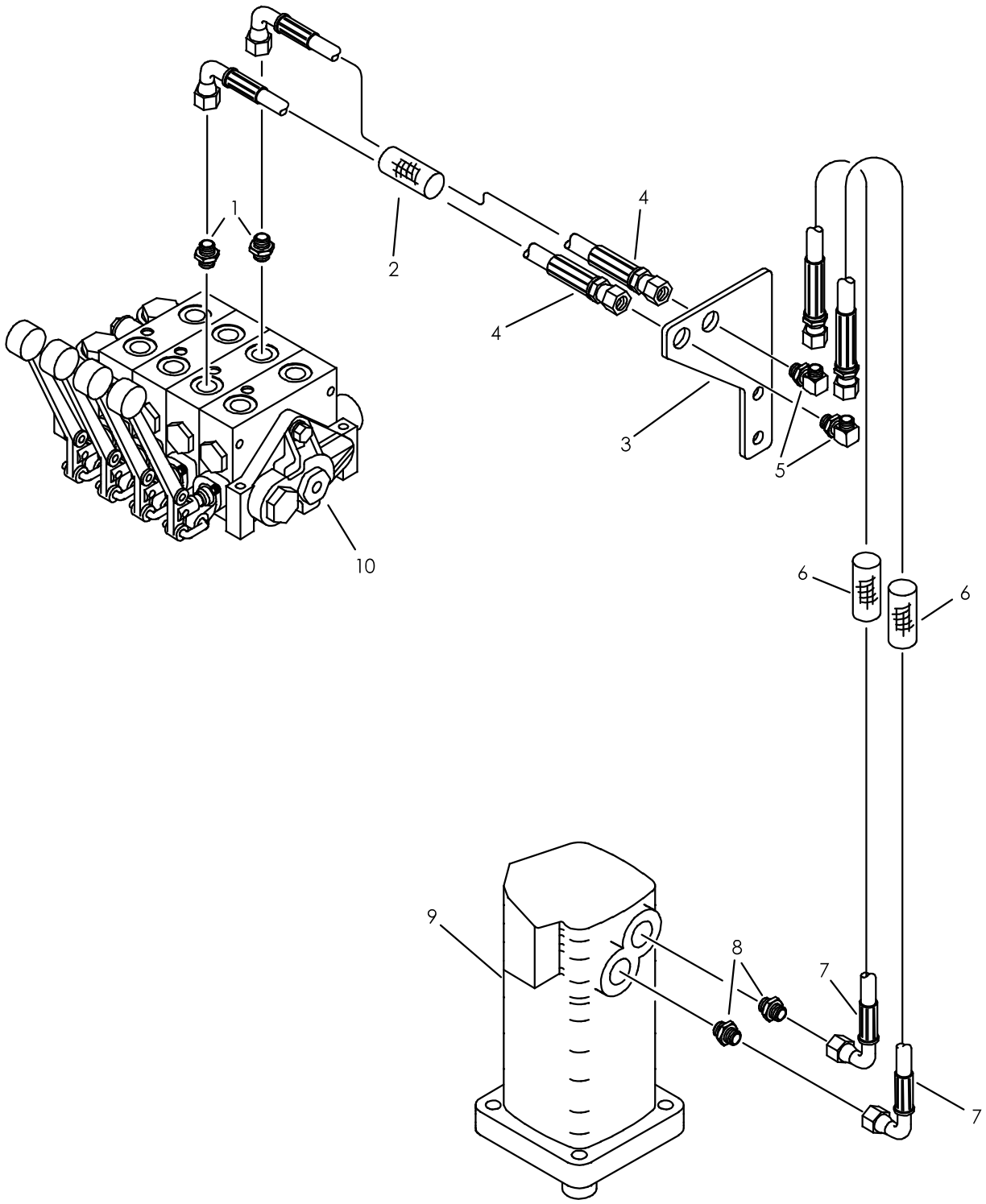

RIGHT ANCHOR MOTOR HYDRAULICS

REF NO.	PART NUMBER	QTY	DESCRIPTION	REMARKS
1.	154-233	2	CONNECTOR (08S-080)	
2.	117-455	1	ABRASION SLEEVE (2.07" X 38")	
3.	309-204	1	BULKHEAD PLATE	
4.	515-025	2	HOSE (080FX90-40"-3000)	
5.	154-396	2	BK CONNECTOR (080-08090BK)	
6.	117-324	2	ABRASION SLEEVE (1.25" X 48")	
7.	154-716	2	HOSE (080FX90-48"-3000)	
8.	154-307	2	CONNECTOR (16S-080)	
9.	149-895	-	HYD MOTOR	
	500-390		SEAL REPAIR KIT - REAR	
	500-391		SEAL REPAIR KIT - SHAFT	
	502-177		SHAFT AND BEARING ASS'Y	
	500-2123		FRONT RETAINER (ANCHOR MOTOR)	
10.	158-064	-	HYD CONTROL VALVE (4-SPOOL)	

NOT SHOWN:

FOOTNOTES:

NOTE:

REFER TO O-RING CHART (800-301) IN BACK OF THE BOOK FOR REPLACEMENT OF O-RINGS

LEFT ANCHOR MOTOR HYDRAULICS

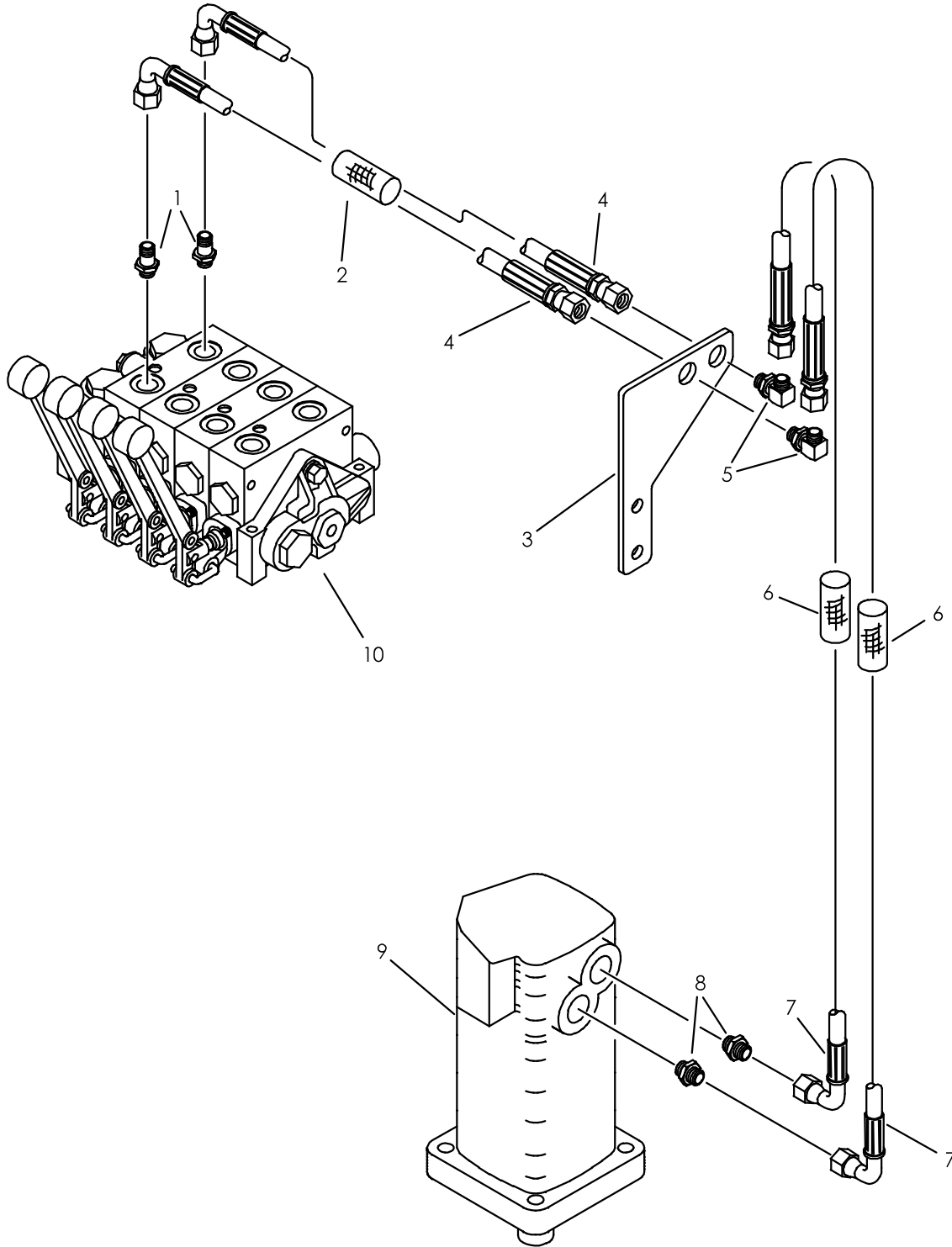

LEFT ANCHOR MOTOR HYDRAULICS

REF NO.	PART NUMBER	QTY	DESCRIPTION	REMARKS
1.	154-438	2	CONNECTOR (08S-080, LG)	
2.	117-293	1	ABRASION SLEEVE (2.07" X 46")	
3.	309-204	1	BULKHEAD PLATE	
4.	154-716	2	HOSE (080FX90-48"-3000)	
5.	154-396	2	BK CONNECTOR (080-08090BK)	
6.	117-324	2	ABRASION SLEEVE (1.25" X 48")	
7.	154-716	2	HOSE (080FX90-48"-3000)	
8.	154-307	2	CONNECTOR (16S-080)	
9.	149-895	-	HYD MOTOR	
	500-390		SEAL REPAIR KIT - REAR	
	500-391		SEAL REPAIR KIT - SHAFT	
	502-177		SHAFT AND BEARING	
10.	158-064	-	HYD CONTROL VALVE (4-SPOOL)	

NOT SHOWN:

FOOTNOTES:

NOTE:

REFER TO O-RING CHART (800-301) IN BACK OF THE BOOK FOR REPLACEMENT OF O-RINGS.

RIGHT ANCHOR THRUST CYLINDER

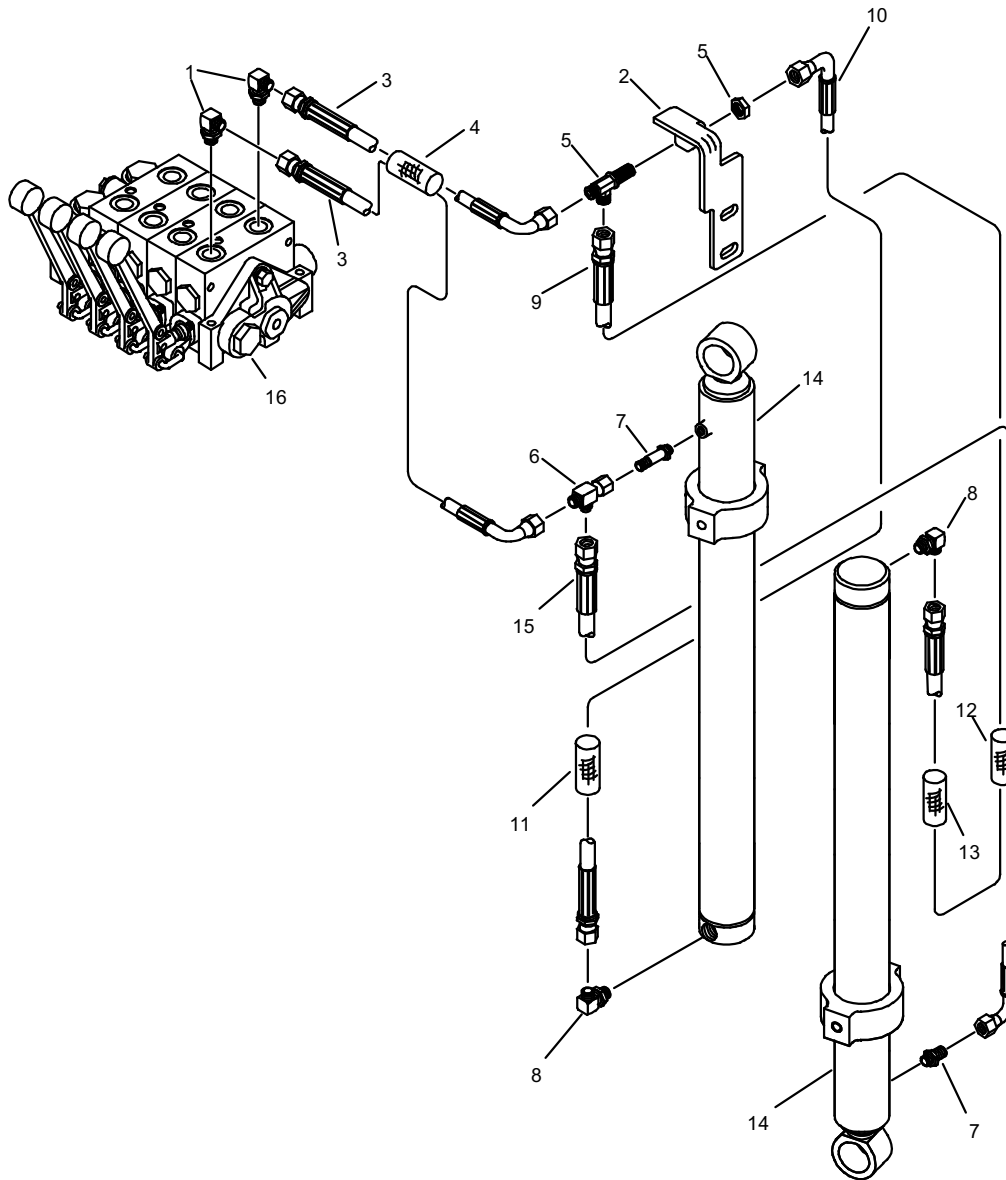

RIGHT ANCHOR THRUST CYLINDER

REF NO.	PART NUMBER	QTY	DESCRIPTION	REMARKS
1.	154-276	2	CONNECTOR (040-08S90)	
2.	309-205	1	BULKHEAD PLATE	
3.	154-728	2	HOSE (040FX90-36"-3000)	
4.	117-655	1	ABRASION SLEEVE (1.59" X 38")	
5.	154-424	1	BK RUN TEE (040-040-040BK)	
6.	154-265	1	UNION RUN TEE (040FX-040-040)	
7.	154-403	2	CONNECTOR (04S-040, XL)	
8.	154-252	2	CONNECTOR (04S-04090)	
9.	515-054	1	HOSE (040FX-74"-3000)	
10.	515-683	1	HOSE (040FX90-28"-3000)	
11.	117-684	1	ABRASION SLEEVE (1.00" X 26")	
12.	117-657	1	ABRASION SLEEVE (1.59" X 54")	
13.	117-676	1	ABRASION SLEEVE (1.00" X 30")	
14.	150-747	2	CYLINDER ASSEMBLY	
15.	515-682	1	HOSE (040FX90M-48"-3000)	
16.	158-064	-	HYD CONTROL VALVE (4-SPOOL)	

NOT SHOWN:

FOOTNOTES:

NOTE:

REFER TO O-RING CHART (800-301) IN BACK OF THE BOOK FOR REPLACEMENT OF O-RINGS.

LEFT ANCHOR THRUST CYLINDER

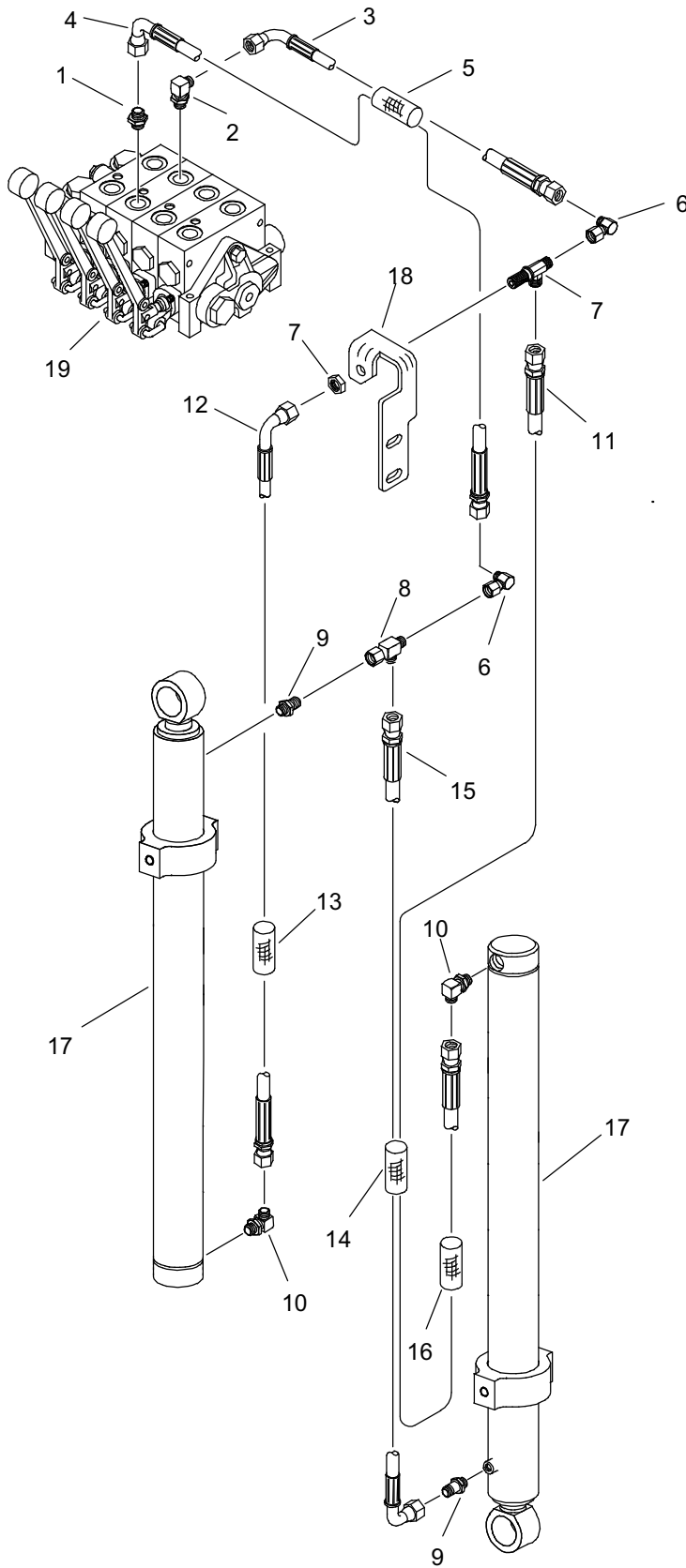

LEFT ANCHOR THRUST CYLINDER

REF NO.	PART NUMBER	QTY	DESCRIPTION	REMARKS
1.	154-261	1	CONNECTOR (040-08S)	
2.	154-276	1	CONNECTOR (040-08S90)	
3.	515-593	1	HOSE (040FX90-38"-3000)	
4.	515-012	1	HOSE (040FX90-42"-3000)	
5.	115-737	1	ABRASION SLEEVE (1.59" X 40")	
6.	154-255	2	UNION (040-040FX90)	
7.	154-424	1	BK RUN TEE (040-040-040BK)	
8.	154-265	1	UNION RUN TEE (040FX-040-040)	
9.	154-403	2	CONNECTOR (04S-040, XL)	
10.	154-252	2	CONNECTOR (04S-04090)	
11.	515-054	1	HOSE (040FX-74"-3000)	
12.	515-683	1	HOSE (040FX90-28"-3000)	
13.	117-684	1	ABRASION SLEEVE (1.00" X 26")	
14.	117-657	1	ABRASION SLEEVE (1.59" X 54")	
15.	515-682	1	HOSE (040FX90M-48"-3000)	
16.	117-676	1	ABRASION SLEEVE (1.00" X 30")	
17.	150-747	2	CYLINDER ASSEMBLY	
18.	309-206	1	BULKHEAD PLATE	
19.	158-064	-	HYD CONTROL VALVE (4-SPOOL)	

NOT SHOWN:

FOOTNOTES:

NOTE:

REFER TO O-RING CHART (800-301) IN BACK OF THE BOOK FOR REPLACEMENT OF O-RINGS.

AUXILIARY VALVE

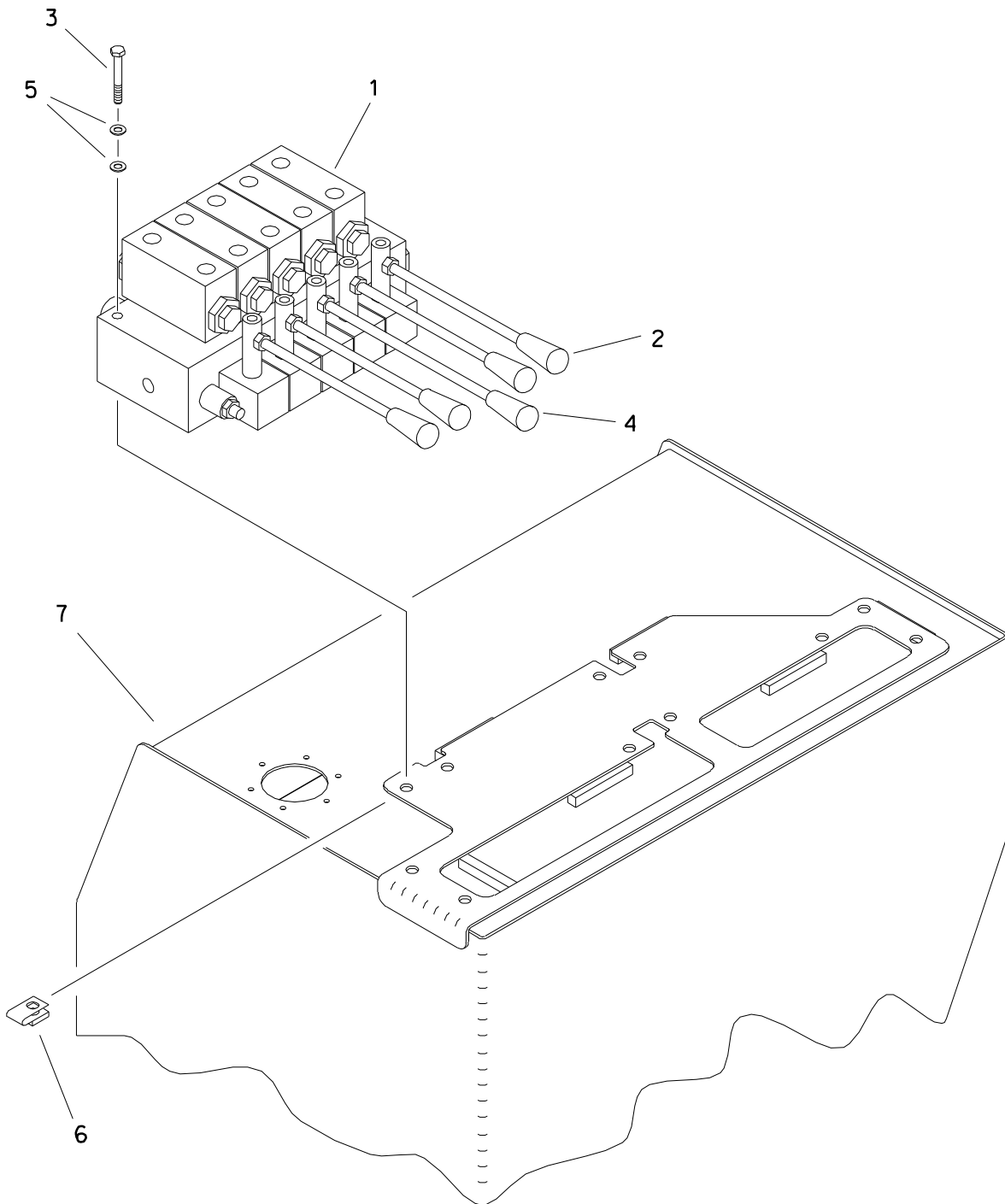

AUXILIARY VALVE

REF NO.	PART NUMBER	QTY	DESCRIPTION	REMARKS
1.	149-882	-	HYD CONTROL VALVE (5-SPOOL)	
2.	365-426	4	LEVER (M8-1.25 X 200MM)	
3.	106-595	3	SCREW (M6-1.00 X 60MM)	
4.	500-502	1	CONTROL VALVE HANDLE	
5.	106-076	6	WASHER (1/4")	
6.	106-574	3	CLIP NUT (M6-1.00)	
7.	350-614	-	HYD RESERVOIR	

FOOTNOTES

AUXILIARY SUPPLY AND RETURN HYDRAULICS

JT 4020 T3

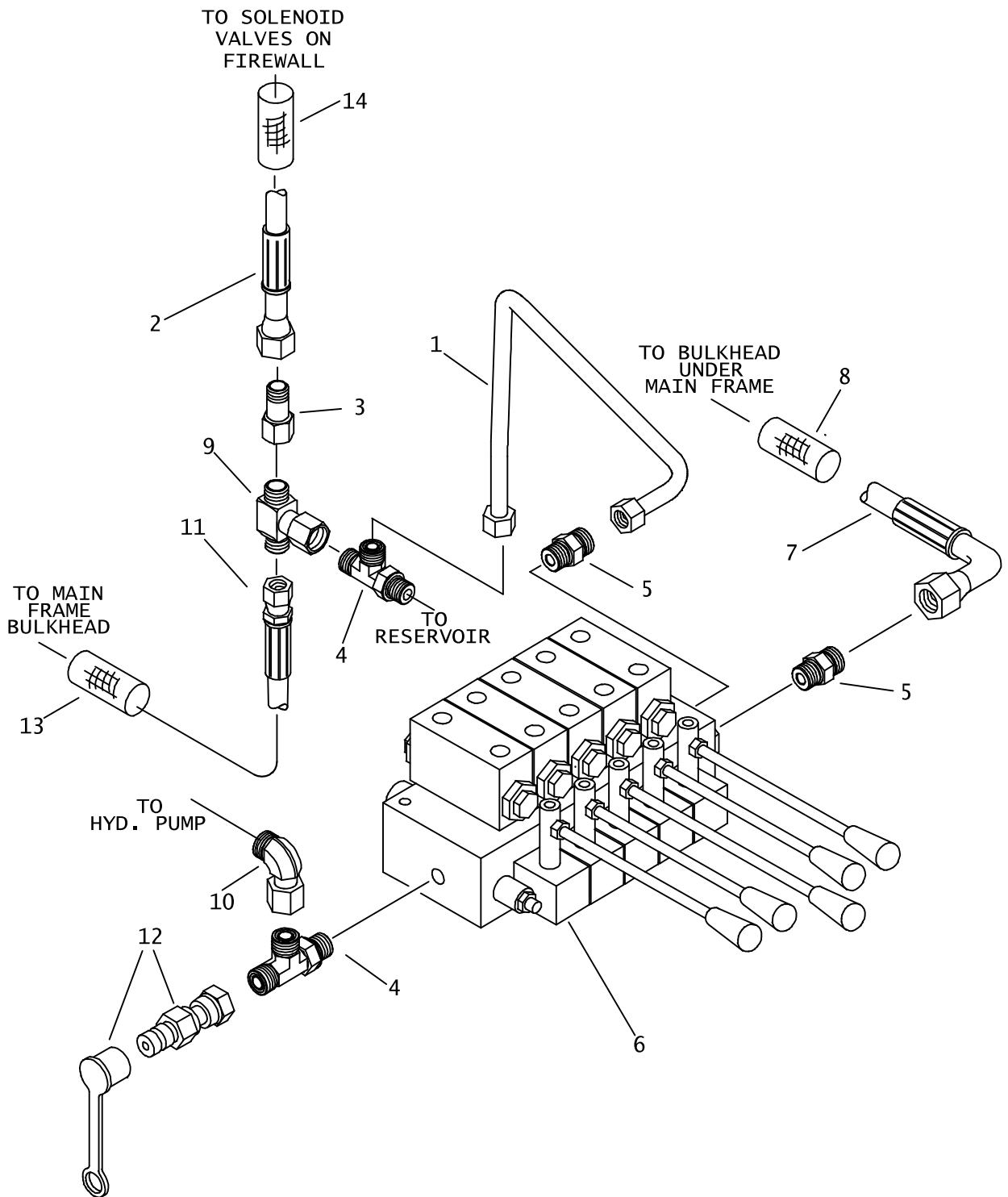

AUXILIARY SUPPLY AND RETURN HYDRAULICS

JT 4020 T3

REF NO.	PART NUMBER	QTY	DESCRIPTION	REMARKS
1.	153-106	1	HYD LINE	
2.	153-315	-	HOSE (060FX90S-36"-3000)	
3.	154-262	1	REDUCER (060-080F)	
4.	154-299	2	RUN TEE (08S-080-080)	
5.	154-233	2	CONNECTOR (08S-080)	
6.	149-882	-	HYD CONTROL VALVE (5-SPOOL)	
7.	515-140	1	HOSE (080FX90-56"-3000)	
8.	117-655	1	ABRASION SLEEVE (1.59" X 38")	
9.	154-257	1	UN BR TEE (080FX-080-080)	
10.	154-256	1	UNION (080-080FX90)	
11.	154-711	1	HOSE (080FX-30"-3000)	
12.	159-158	1	QDC ADAPTER (02-080FX)	
	159-148	-	DUST CAP (1/8")	
13.	117-396	1	ABRASION SLEEVE (1.25" X 28")	
14.	117-412	1	ABRASION SLEEVE (1.0" X 34")	

NOT SHOWN:

FOOTNOTES:

NOTE:

REFER TO O-RING CHART (800-301) IN BACK OF THE BOOK FOR REPLACEMENT OF O-RINGS.

STABILIZER HYDRAULICS

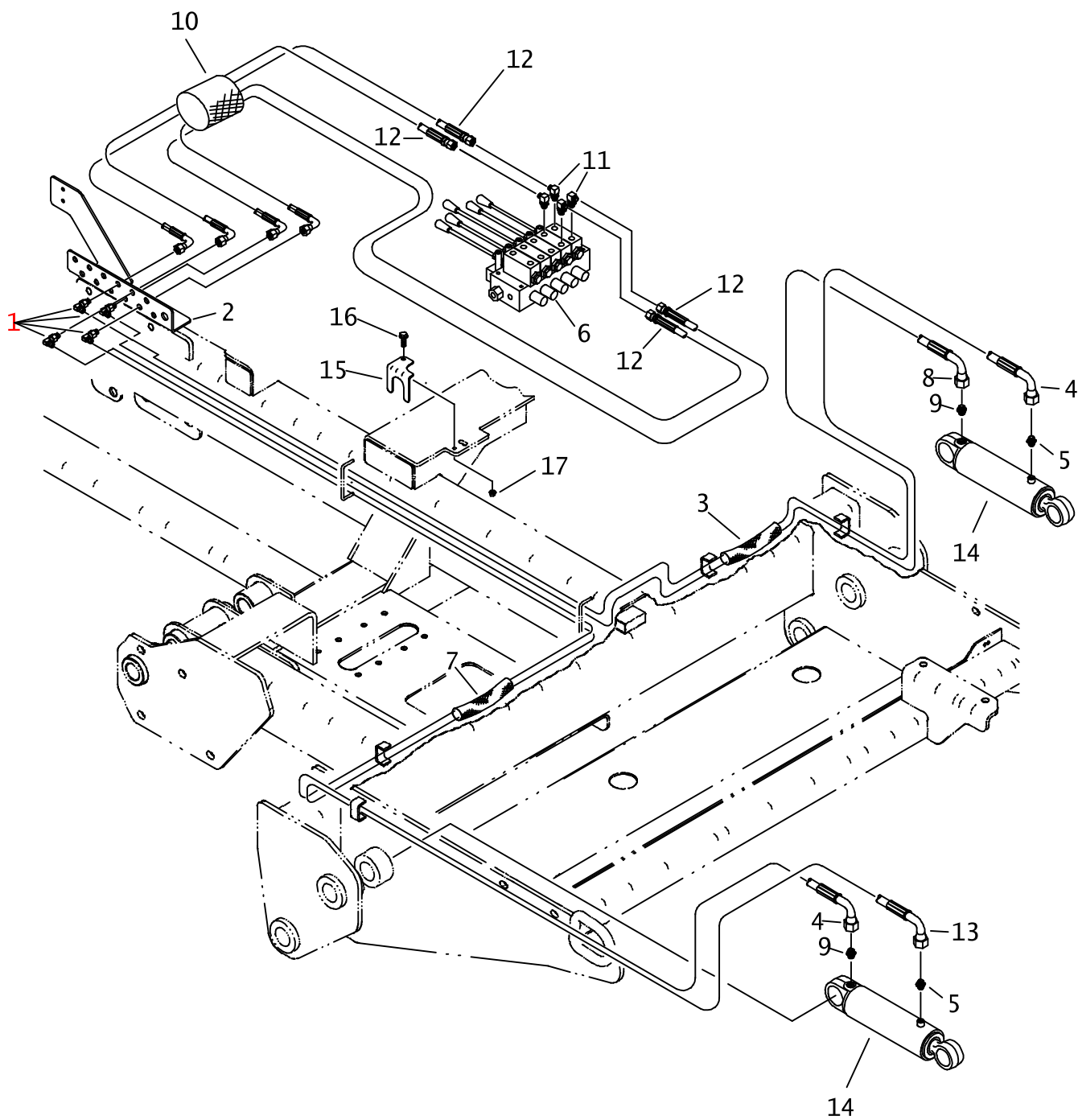

STABILIZER HYDRAULICS

REF NO.	PART NUMBER	QTY	DESCRIPTION	REMARKS
1.	154-355	4	BK CONNECTOR (040-04090BK)	
2.	354-466	-	BULKHEAD PLATE	
3.	116-633	1	ABRASION SLEEVE (1.59" X 115")	
4.	515-277	2	HOSE (040FX90S-128"-3000)	
5.	154-261	2	CONNECTOR (040-08S)	
6.	149-882	1	HYD CONTROL VALVE (5-SPOOL)	
7.	116-632	1	ABRASION SLEEVE (1.59" X 130")	
8.	515-239	1	HOSE (040FX90S-116"-3000)	
9.	154-374	1	CONNECTOR (040-08S, ORF)	
10.	117-789	-	HOSE BAG (4" X 36")	
11.	154-226	4	CONNECTOR (040-06S90)	
12.	515-439	4	HOSE (040FX90S-50"-3000)	
13.	515-146	1	HOSE (040FX90S-140"-3000)	
14.	151-187	2	CYLINDER ASSEMBLY	4" X 2" X 10"
15.	309-549	1	BRACKET	
16.	106-381	1	FLG LK SCREW (M8-1.25 X 25MM)	
17.	106-386	1	FLG LOCKNUT (M8-1.25)	

NOT SHOWN:

FOOTNOTES:

NOTE:

REFER TO O-RING CAHRT (800-301) IN BACK OF THE BOOK FOR REPLACEMENT OF O-RINGS.

SHUTTLE STOP HYDRAULICS

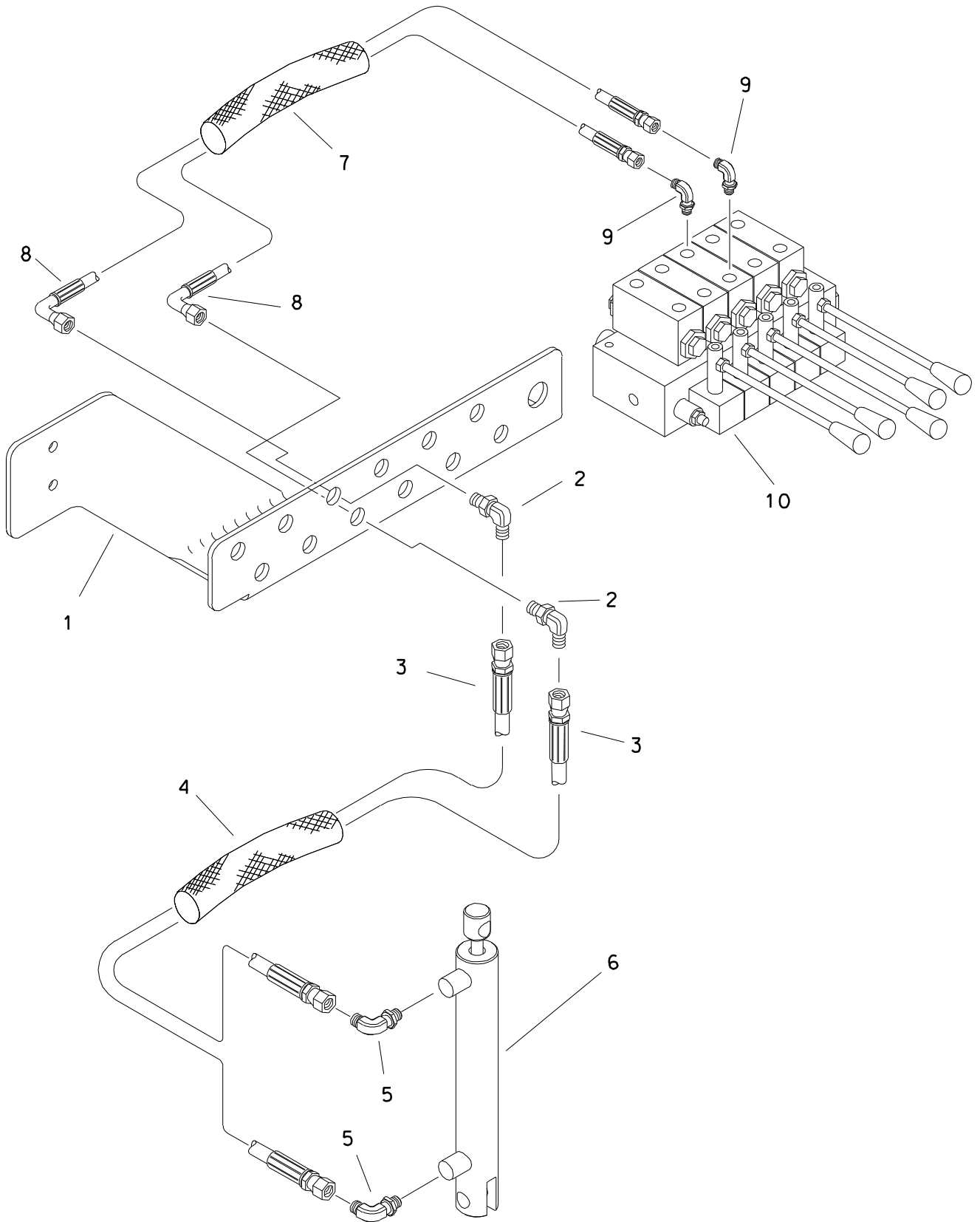

SHUTTLE STOP HYDRAULICS

REF NO.	PART NUMBER	QTY	DESCRIPTION	REMARKS
1.	354-466	1	BULKHEAD PLATE	
2.	154-355	2	BK CONNECTOR (040-04090BK)	
3.	515-161	2	HOSE (040FX-160"-3000)	
4.	117-741	1	ABRASION SLEEVE (1.59" X 145")	
5.	154-401	2	CONNECTOR (04S-04090, ORF)	
6.	150-727	1	CYL (1.0" X .500" X 4.0")	
7.	117-789	-	HOSE BAG (4.000" X 36")	
8.	515-447	2	HOSE (040FX90S-48"-3000)	
9.	154-226	2	CONNECTOR (040-06S90)	
10.	149-882	-	HYD CONTROL VALVE (5-SPOOL)	

FOOTNOTES

NOTE
REFER TO O-RING CHART (800-301) IN BACK OF THE BOOK FOR THE REPLACEMENT OF O-RINGS.

FRAME TILT HYDRAULICS

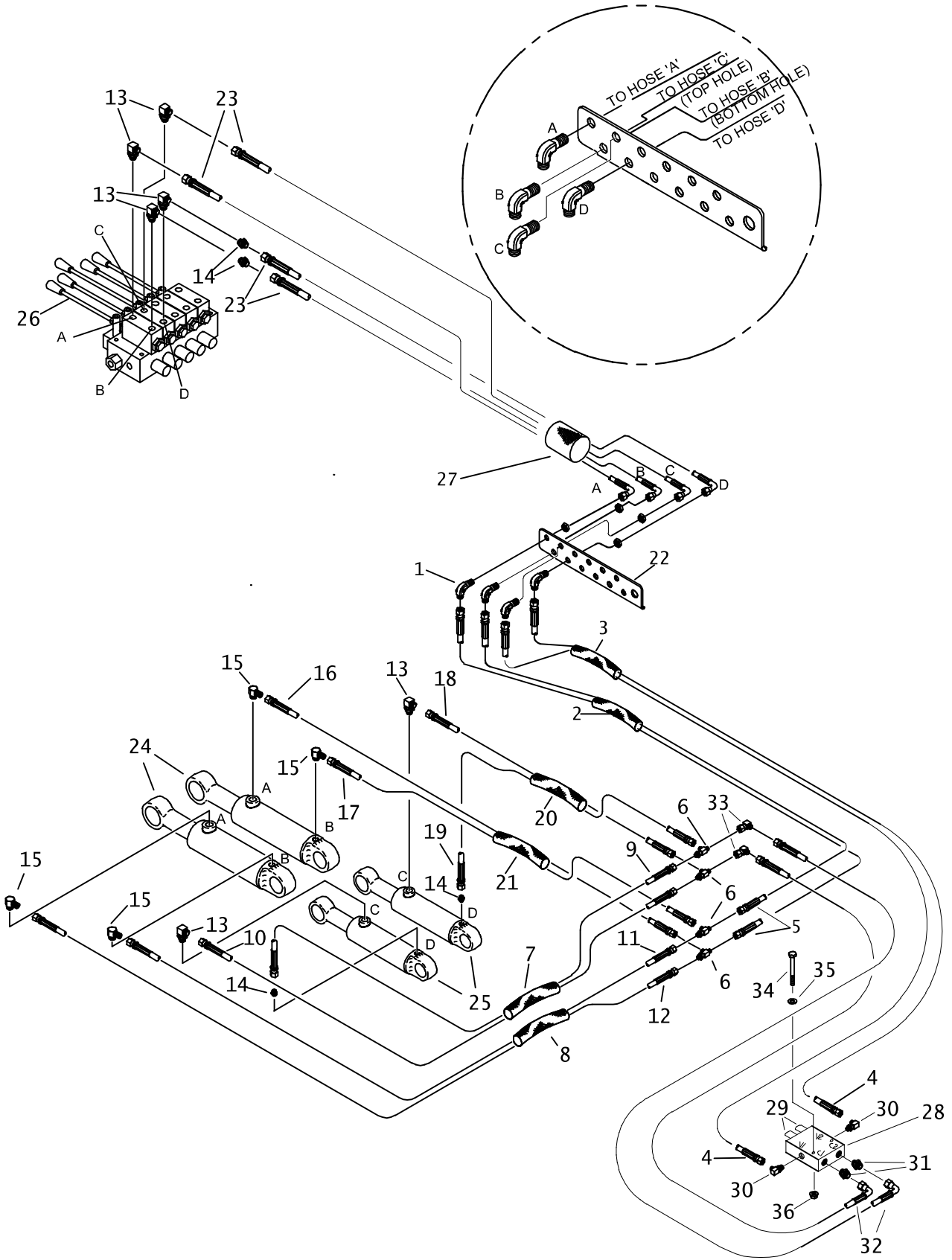

FRAME TILT HYDRAULICS

REF NO.	PART NUMBER	QTY	DESCRIPTION	REMARKS
1.	154-355	4	BK CONNECTOR (040-04090BK)	
2.	117-603	1	ABRASION SLEEVE (1.59" X 62")	
3.	117-656	1	ABRASION SLEEVE (1.59" X 45")	
4.	515-424	2	HOSE (040FX-56"-3000)	
5.	154-681	2	HOSE (040FX-62"-3000)	
6.	154-424	4	BK RUN TEE (040-040-040BK)	
7.	115-777	1	ABRASION SLEEVE (1.59" X 15")	
8.	117-679	1	ABRASION SLEEVE (1.59" X 32")	
9.	154-672	1	HOSE (040FX-15"-3000)	
10.	515-735	1	HOSE (040FX-22"-3000)	
11.	154-668	1	HOSE (040FX-32"-3000)	
12.	154-653	1	HOSE (040FX-40"-3000)	
13.	154-226	6	CONNECTOR (040-06S90)	
14.	154-220	2	CONNECTOR (040-06S)	
15.	154-276	4	CONNECTOR (040-08S90)	
16.	154-911	1	HOSE (040FX-36"-3000AR)	
17.	515-509	1	HOSE (040FX-28"-3000)	
18.	155-484	1	HOSE (040FX-16"-3000)	
19.	154-719	1	HOSE (040FX-10"-3000)	
20.	115-776	1	ABRASION SLEEVE (1.59" X 7")	
21.	117-708	1	ABRASION SLEEVE (1.59" X 28")	
22.	354-466	-	BULKHEAD PLATE	
23.	515-447	4	HOSE (040FX90S-48"-3000)	
24.	151-066	2	CYL (4.0 X 2.0 X 5.0)	
25.	151-070	2	CYL (3.0" X 1.75" X 8.000")	
26.	149-882	-	HYD CONTROL VALVE (5-SPOOL)	
27.	117-789	1	HOSE BAG (4.000" X 36")	ALL HOSES FROM VALVE (149-882) GO INTO HOSE BAG.
28.	502-184	1	VALVE BLOCK	SEE FOOTNOTE 1
29.	500-478	2	COUNTERBALANCE CARTRIDGE KIT	SEE FOOTNOTE 1 & 2
30.	154-226	2	CONNECTOR (040-06S90)	SEE FOOTNOTE 1
31.	154-220	2	CONNECTOR (040-06S)	SEE FOOTNOTE 1
32.	154-726	2	HOSE (040FX90-15"-3000)	SEE FOOTNOTE 1
33.	154-255	2	UNION (040-040FX90)	SEE FOOTNOTE 1
34.	106-570	1	SCREW (M8-1.25 X 60MM)	SEE FOOTNOTE 1
35.	105-117	1	WASHER (5/16")	SEE FOOTNOTE 1
36.	106-386	1	FLG LOCKNUT (M8-1.25)	SEE FOOTNOTE 1

NOT SHOWN:

FOOTNOTES:

1. USE ON 4020 WITH RACK AND PINION
2. TURN ADJUSTMENT SCREW COMPLETELY OUT

NOTE:

REFER TO O-RING CHART (800-301) IN BACK OF THE BOOK FOR REPLACEMENT OF O-RINGS.

PIPE LOADER SUPPLY AND RETURN

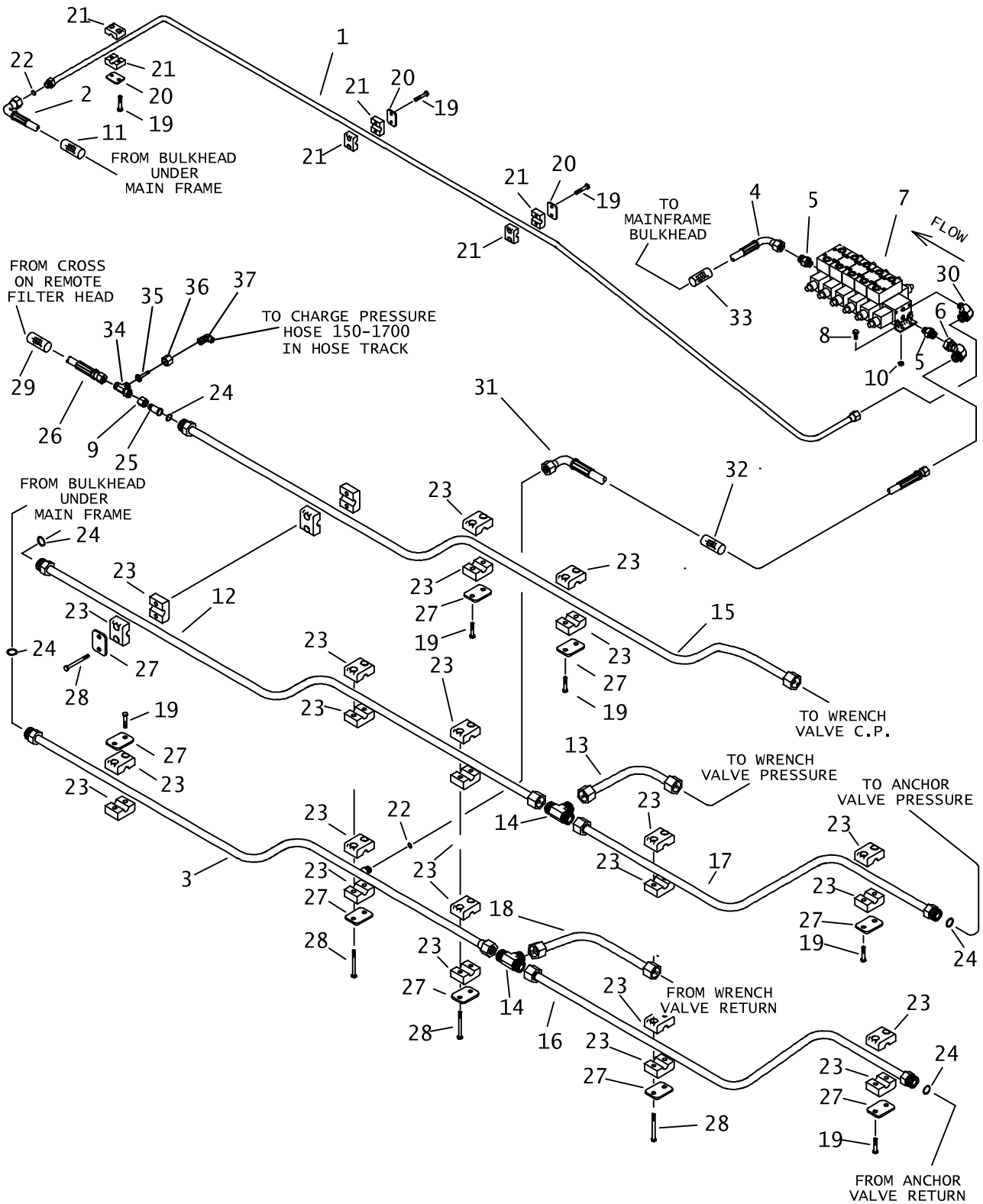

PIPE LOADER SUPPLY AND RETURN

REF NO.	PART NUMBER	QTY	DESCRIPTION	REMARKS
1.	149-449	1	HYD LINE	
2.	515-141	1	HOSE (080FX90-82"-3000)	
3.	149-447	1	HYD LINE	
4.	515-741	1	HOSE (080FX90S-112"-3000)	
5.	154-246	2	CONNECTOR (06S-080)	
6.	154-256	1	UNION (080-080FX90)	
7.	157-764	1	HYDRAULIC VALVE	
8.	106-379	4	FLG LK SCREW (M6-1.00 X 20MM)	
9.	154-310	1	REDUCER NUT (100F)	
10.	106-385	4	FLG LOCKNUT (M6-1.00)	
11.	117-390	1	ABRASION SLEEVE (1.25" X 85")	
12.	149-446	1	HYD LINE	
13.	149-476	1	HYD LINE	
14.	154-455	2	TEE (120)	
15.	149-448	1	HYD LINE	
16.	149-444	1	HYD LINE	
17.	149-445	1	HYD LINE	
18.	149-477	1	HYD LINE	
19.	105-818	16	BOLT (1/4-NC X 1-1/2")	
20.	110-958	3	BACKUP PLATE	
21.	110-866	3	CLAMP (1/2")	
22.	157-039	2	O-RING (014 D90)	
23.	110-411	13	BOLT-ON CLAMP (3/4", SET)	
24.	157-040	5	O-RING (016 D90)	
25.	154-312	1	REDUCER STEM (080)	
26.	154-877	1	HOSE (080FX90-90"-3000)	
27.	322-289	9	BACKUP (BOLT-ON)	
28.	107-196	8	SCREW (1/4-NC X 3.0, GD 5)	
29.	117-211	1	ABRASION SLEEVE (1.25" X 90")	
30.	154-253	1	CONNECTOR (06S-08090)	
31.	154-740	1	HOSE (080FX90S-26"-3000)	
32.	117-337	1	ABRASION SLEEVE (1.25" X 25")	
33.	117-389	1	ABRASION SLEEVE (1.25" X 104")	
34.	154-266	1	UNION RUN TEE (080FX-080-080)	SEE FOOTNOTE I
35.	154-248	1	REDUCER STEM (040)	SEE FOOTNOTE I
36.	154-272	1	REDUCER NUT (080F)	SEE FOOTNOTE I
37.	154-255	1	UNION (040-040FX90)	SEE FOOTNOTE I

NOT SHOWN:

FOOTNOTES:

I. USE ON 4020 WITH RACK AND PINION

NOTE:

REFER TO O-RING CHART (800-301) IN BACK OF THE BOOK FOR REPLACEMENT OF O-RINGS.

PIPE SHUTTLE HYDRAULICS

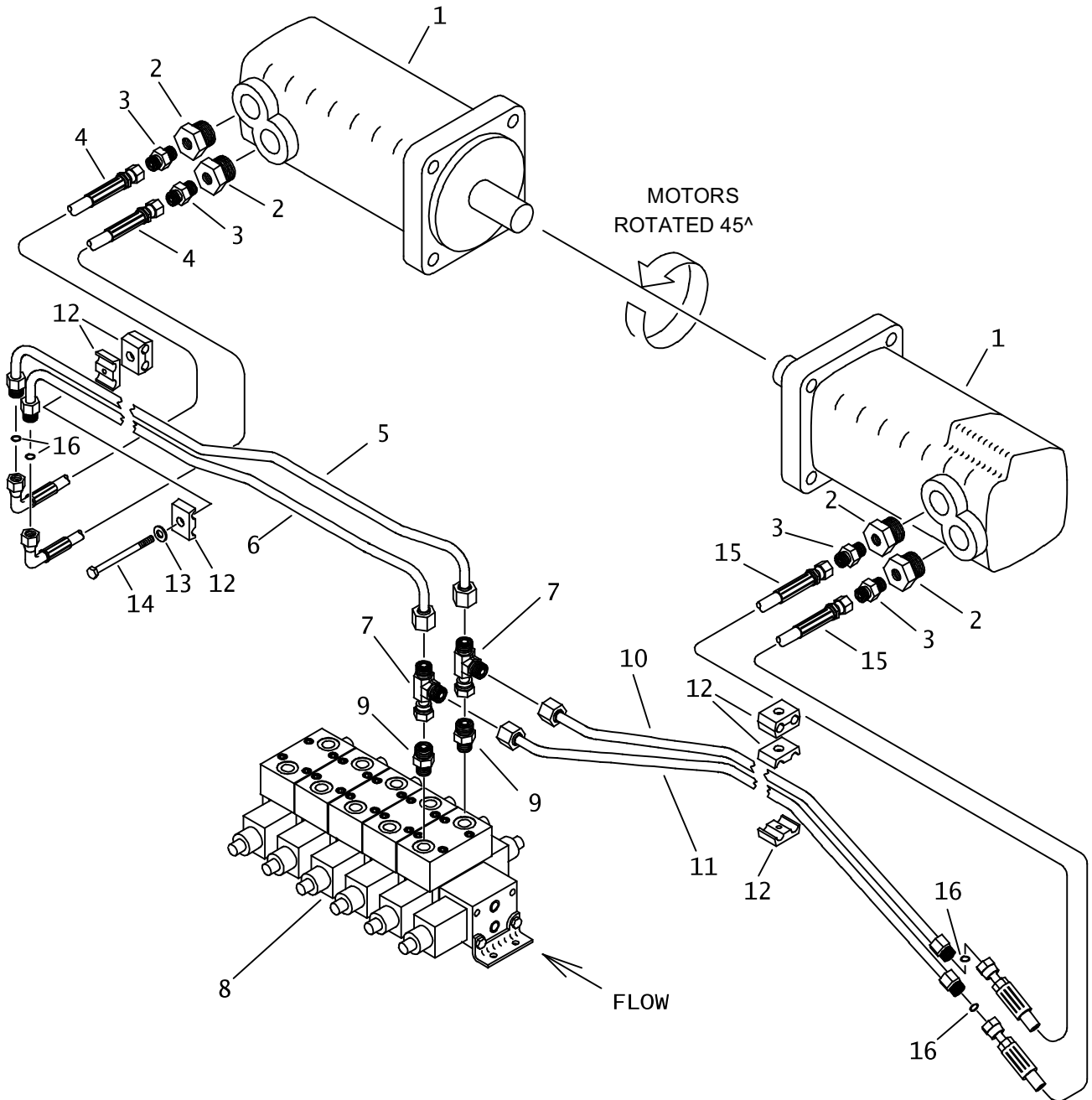

PIPE SHUTTLE HYDRAULICS

REF NO.	PART NUMBER	QTY	DESCRIPTION	REMARKS
1.	158-026	-	HYDRAULIC MOTOR (15 CU/IN)	
	500-1552	-	SEAL REPAIR KIT	
	500-1553	-	SHAFT AND BEARING KIT	
	500-711	-	SEAL REPAIR KIT-REAR	
	500-758	-	SEAL REPAIR KIT-SHAFT	
2.	155-129	4	REDUCER (12S-06SF)	
3.	154-220	4	CONNECTOR (040-06S)	
4.	515-175	2	HOSE (040FX90-16"-3000)	
5.	153-673	1	HYD LINE	TOP
6.	153-674	1	HYD LINE	BOTTOM
7.	154-344	2	UN RUN TEE (060FX-060-060)	
8.	157-764	-	HYDRAULIC VALVE	
9.	154-221	2	CONNECTOR (06S-060)	
10.	149-426	1	HYD LINE	
11.	149-959	1	HYD LINE	
12.	110-998	8	CLAMP HALVES (3/8") PAIR	
13.	105-117	5	WASHER (5/16")	
14.	105-297	5	BOLT (1/4-NC X 3-1/4")	
15.	154-800	2	HOSE (040FX-18"-3000)	SEE FOOTNOTE 1
16.	157-037	4	O-RING (011 D90)	

NOT SHOWN:

FOOTNOTES:

- I. ON MACHINES PRIOR TO RACK AND PINION, USE 155-484 TO REPLACE THIS HOSE

NOTE:

PIPE LIFTER HYDRAULICS

JT4020 ALL TERRAIN ONLY

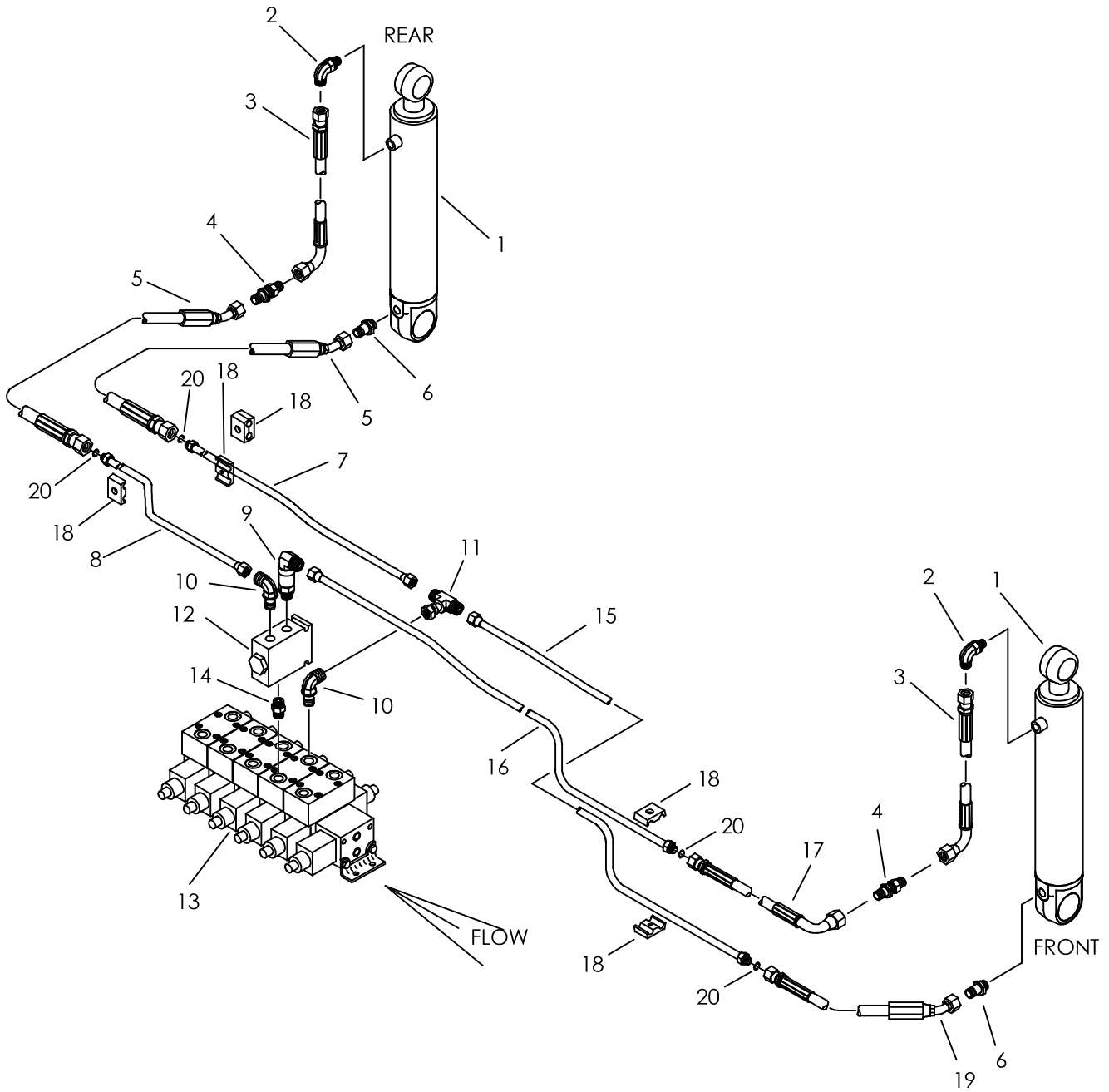

PIPE LIFTER HYDRAULICS

JT4020 ALL TERRAIN ONLY

REF NO.	PART NUMBER	QTY	DESCRIPTION	REMARKS
1.	151-031	2	CYL (2.0" X 1.0" X 8.0")	
2.	154-252	2	CONNECTOR (04S-04090)	
3.	515-179	2	HOSE (040FX90-11"-3000)	
4.	154-275	2	BK CONNECTOR (040-040BK)	
5.	515-072	2	HOSE (040FX45-16"-3000)	
6.	154-403		CONNECTOR (04S-040, XL)	
7.	153-669	1	HYD LINE	TOP
8.	153-670	1	HYD LINE	BOTTOM
9.	154-471	1	CONNECTOR (060-06S90, LG)	
10.	154-342	2	CONNECTOR (06S-06090)	
11.	154-348	1	UN BR TEE (060FX-060-060)	
12.	516-087	1	FLOW DIVIDER	
13.	157-764	1	HYDRAULIC VALVE	
14.	155-153	1	CONNECTOR (06S-06S)	
15.	149-439	1	HYD LINE	
16.	149-440	1	HYD LINE	
17.	515-175	1	HOSE (040FX90-16"-3000)	
18.	110-998	7	CLAMP HALVES (3/8") PAIR	
19.	154-934	1	HOSE (040FX45-18"-3000)	
20.	157-037	4	O-RING (011 D90)	

NOT SHOWN:

FOOTNOTES:

NOTE:

GRIPPER HYDRAULICS

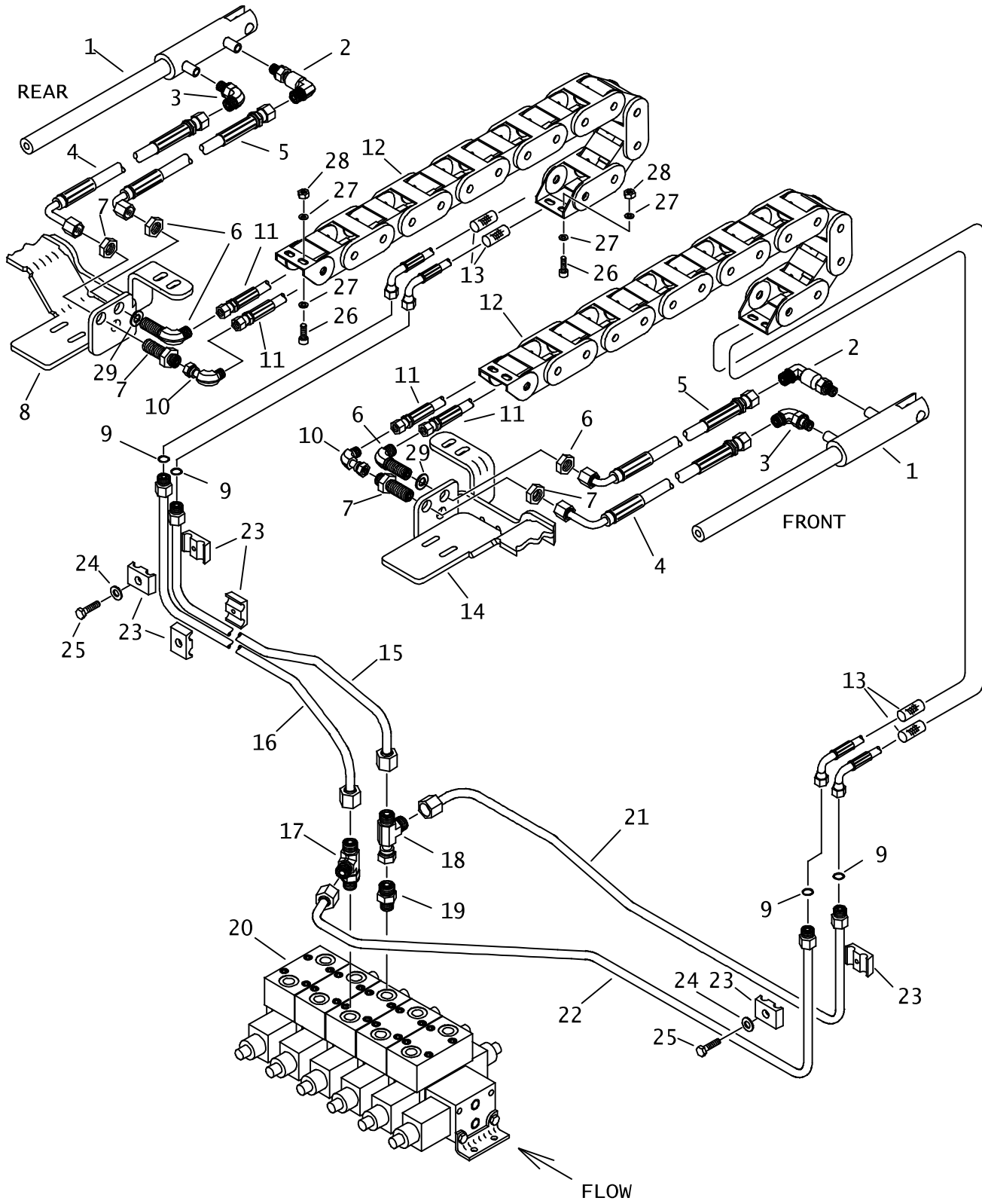

GRIPPER HYDRAULICS

1.	150-731	2	CYL ASS'Y	
2.	154-474	2	CONNECTOR (04S-04090,XL)	
3.	154-252	2	CONNECTOR (04S-04090)	
4.	157-362	2	HOSE (040FX90L-11"-3000)	
5.	515-598	2	HOSE (040FX90-12"-3000)	
6.	154-355	2	BK CONNECTOR (040-04090BK)	
7.	154-275	2	BK CONNECTOR (040-040BK)	
8.	313-684	-	REAR SHUTTLE	
9.	157-037	4	O-RING (011 D90)	
10.	154-255	2	UNION (040-040FX90)	
11.	153-365	4	HOSE (040FX90S-34"-3000)	
12.	306-746	2	HOSE TRACK	
13.	117-412	4	ABRASION SLEEVE (1.25" X 34")	
14.	313-683	-	FRONT SHUTTLE	
15.	153-671	1	HYD LINE	TOP
16.	153-672	1	HYD LINE	BOTTOM
17.	153-667	1	SPECIAL TEE (06S,ORF-060-060)	
18.	154-344	1	UN RUN TEE (060FX-060-060)	
19.	156-067	1	CONNECTOR (06S-060, ORF .031")	
20.	157-764	-	HYDRAULIC VALVE	
21.	149-427	1	HYD LINE	TOP
22.	149-428	1	HYD LINE	BOTTOM
23.	110-998	6	CLAMP HALVES (3/8") PAIR	
24.	105-117	2	WASHER (5/16")	
25.	105-197	2	BOLT (1/4-NC X 1")	
26.	106-640	8	SCREW (M6-1.00 X 20MM, BUT SOC)	
27.	105-284	16	WASHER (3/16")	
28.	106-237	8	LOCKNUT (M6-1.00,PRV TRQ,NLK)	
29.	106-598	2	WASHER (9/16" HARDENED)	

GREASER HYDRAULICS

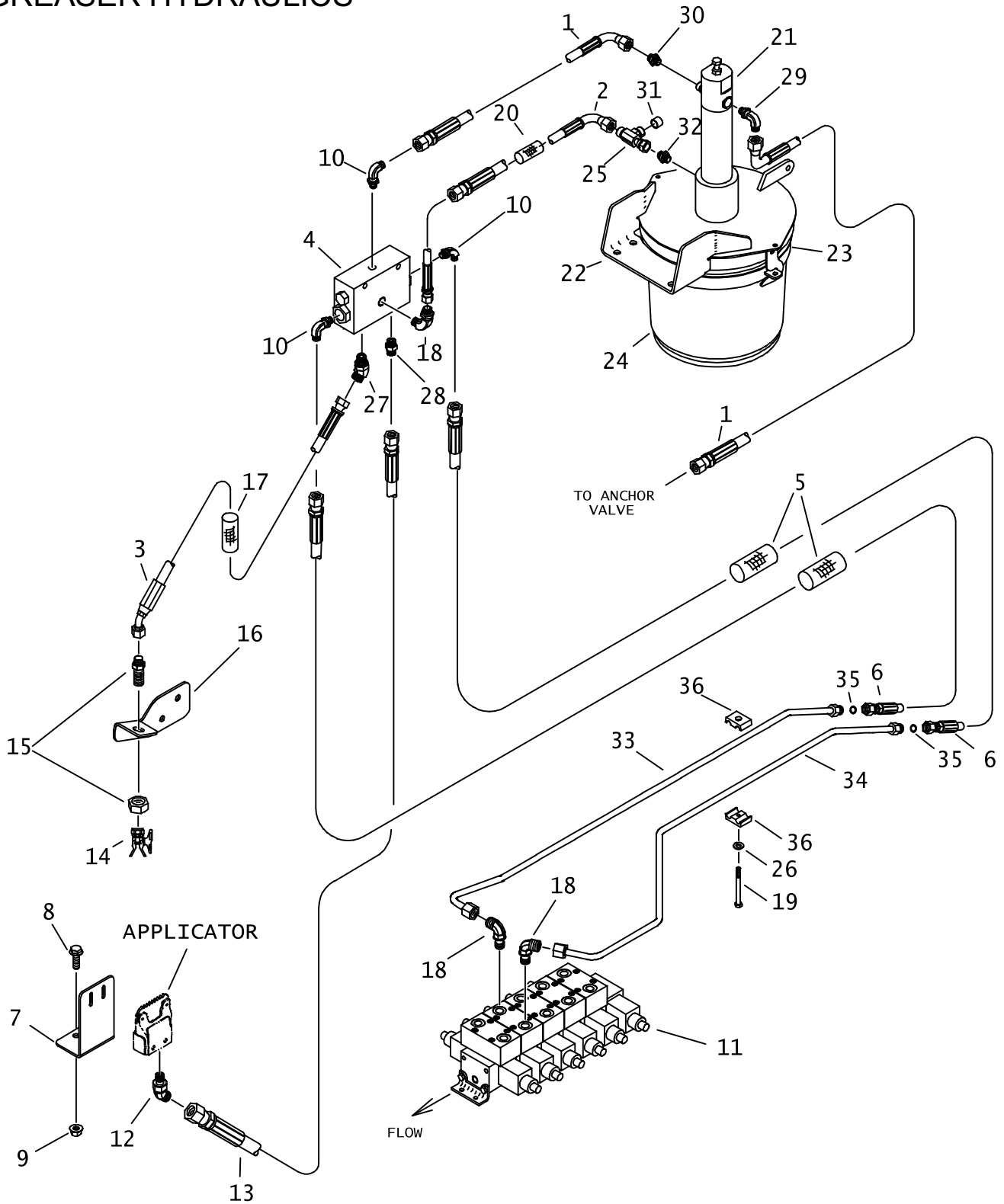

GREASER HYDRAULICS

REF NO.	PART NUMBER	QTY	DESCRIPTION	REMARKS
1.	149-827	2	HOSE (040FX90S-24"-3000)	
2.	153-320	1	HOSE (060FX90L-17"-3000)	
3.	149-825	1	HOSE (060FX90L-28"-3000)	
4.	310-591	1	VALVE ASS'Y	SEE FOOTNOTE 3
5.	117-211	2	ABRASION SLEEVE (1.25" X 90")	
6.	154-724	2	HOSE (040FX-82"-3000)	
7.	318-607	1	BRACKET, WIPER	SEE FOOTNOTE 4
	327-1086	1	BRACKET, WIPER	SEE FOOTNOTE 5
8.	106-724	2	FLG SCREW (M10-1.50 X 25MM)	
9.	106-387	2	FLG LOCKNUT (M10-1.50)	
10.	154-252	3	CONNECTOR (04S-04090)	
11.	157-764	-	HYDRAULIC VALVE	SEE FOOTNOTE 3
12.	514-414	1	CONNECTOR (04S-06045)	
13.	153-424	1	HOSE (060FX-236"-3000)	
14.	401-155	1	SPRAY NOZZLE	
	191-258	1	SPRAY NOZZLE HANDLE KIT	
	153-096	1	CAP GASKET, NYLON	
15.	514-163	1	BK CONNECTOR (060-060BK)	
16.	318-854	-	BRACKET, SPRAY	
17.	117-684	1	ABRASION SLEEVE (1.00" X 26")	
18.	154-342	3	CONNECTOR (06S-06090)	
19.	105-297	1	BOLT (1/4-NC X 3-1/4")	
20.	117-194	1	ABRASION SLEEVE (1.00" X 16")	
21.	350-398	-	GREASE PUMP	
22.	350-400	-	COVER	
23.	350-399	-	BASE	
24.	259-858	-	TOOL JNT LUBE, STD SPRY 2 GAL	
	256-031	-	TOOL JNT LUBE, SUMR SPRY 2 GAL	
25.	154-344	1	UN RUN TEE (060FX-060-060)	
26.	105-117	1	WASHER (5/16")	
27.	154-224	1	CONNECTOR (06S-06045)	SEE FOOTNOTE 1
28.	514-165	1	CONNECTOR (06S-060, ORF .078")	SEE FOOTNOTE 2
29.	154-401	1	CONNECTOR (04S-04090, ORF)	

NOT SHOWN:

FOOTNOTES:

1. TO SPRAY NOZZEL.
2. TO REAR APPLICATOR.
3. FOR PARTS BREAKDOWN OF SELECTOR VALVE & APPLICATOR, SEE SPECIFIC PARTS PAGES.
4. USE SCREWS WITH APPLICATOR TO ATTACH TO BRACKET.
5. USE ON 4020 WITH RACK AND PINION.

NOTE:

REFER TO O-RING CHART (800-301) ON BACK OF THE BOOK FOR REPLACEMENT OF O-RINGS.

GREASER HYDRAULICS

REF NO.	PART NUMBER	QTY	DESCRIPTION	REMARKS
30.	154-278	1	CONNECTOR (04S-040)	
31.	154-326	1	CAP (060F)	
32.	154-221	1	CONNECTOR (06S-060)	
33.	149-956	1	HYD LINE	
34.	149-957	1	HYD LINE	
35.	157-037	2	O-RING (011 D90)	
36.	110-998	1	CLAMP HALVES (3/8") PAIR	

NOT SHOWN:

FOOTNOTES:

NOTE:

REFER TO O-RING CHART (800-301) ON BACK OF THE BOOK FOR REPLACEMENT OF O-RINGS.

SEAT ROTATION HYDRAULICS

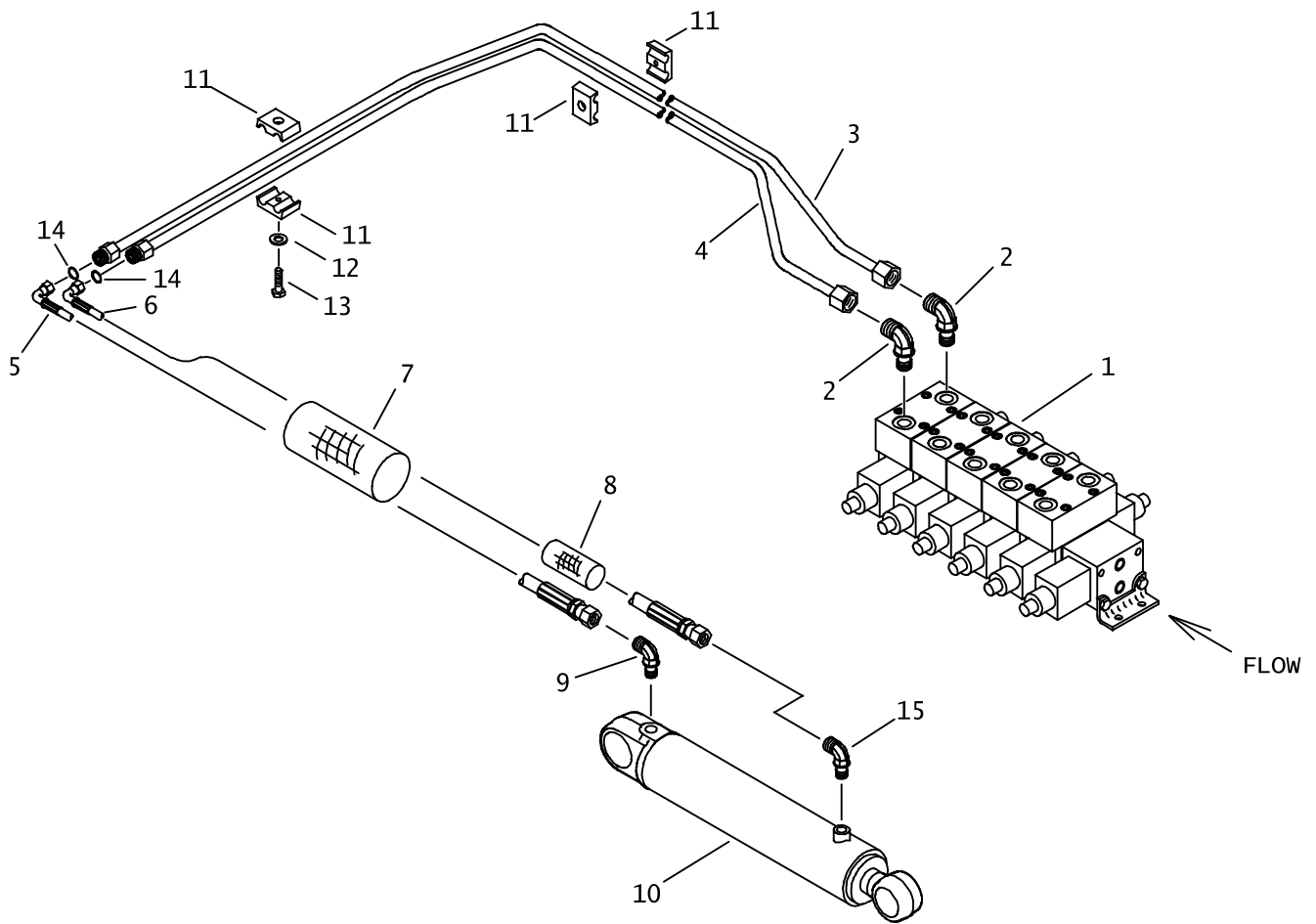

SEAT ROTATION HYDRAULICS

REF NO.	PART NUMBER	QTY	DESCRIPTION	REMARKS
1.	157-764	-	HYDRAULIC VALVE	
2.	154-342	2	CONNECTOR (06S-06090)	
3.	149-450	1	HYD LINE	TOP
4.	149-451	1	HYD LINE	BOTTOM
5.	515-203	1	HOSE (040FX90-135"-3000)	
6.	515-146	1	HOSE (040FX90S-140"-3000)	
7.	117-619	1	ABRASION SLEEVE (1.59" X 135")	
8.	117-671	1	ABRASION SLEEVE (1.00" X 12")	
9.	154-401	1	CONNECTOR (04S-04090, ORF)	
10.	151-031	1	CYL (2.0" X 1.0" X 8.0")	
11.	110-998	5	CLAMP HALVES (3/8") PAIR	
12.	105-117	1	WASHER (5/16")	
13.	105-197	1	BOLT (1/4-NC X 1")	
14.	157-037	2	O-RING (011 D90)	
15.	154-252	1	CONNECTOR (04S-04090)	

NOT SHOWN:

FOOTNOTES:

NOTE:

REFER TO O-RING CHART (800-301) IN BACK OF THE BOOK FOR REPLACEMENT OF O-RINGS.

HYDRAULIC CYLINDER (2.0" X 1.00" X 8.0")

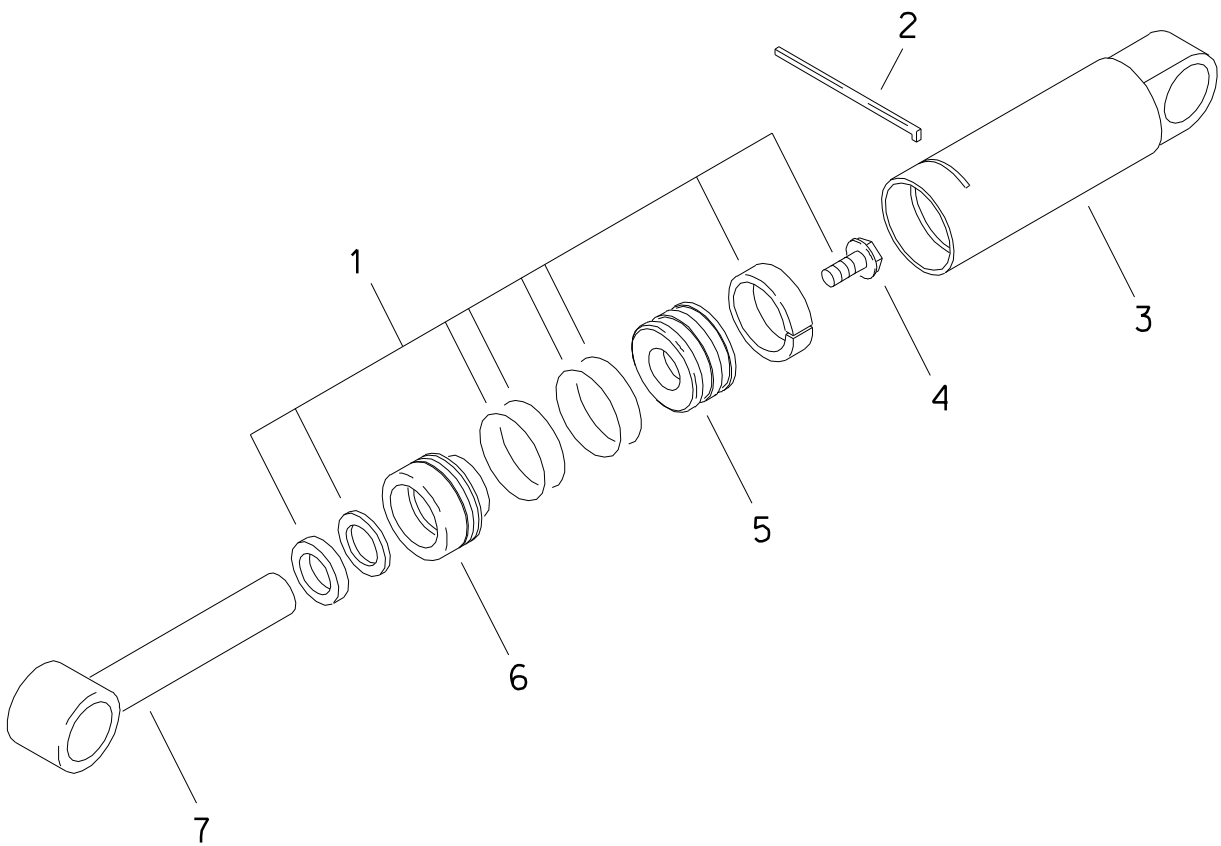

HYDRAULIC CYLINDER (2.0" X 1.00" X 8.0")

REF NO.	PART NUMBER	QTY	DESCRIPTION	REMARKS
	151-031		CYL (2.0" X 1.0" X 8.0")	INCL. REF. NO.'S 1 THRU 7
1.	190-165	1	SEAL REPAIR KIT (2" X 1")	
2.	150-778	1	LOCK RING (2")	
3.	150-285	1	CYLINDER BARREL (2")	
4.	106-096	1	FLG BOLT (1/2-NC X 1-3/4", GD8)	SEE FOOTNOTE 1
5.	150-775	1	CYLINDER PISTON (2.0" X 1.0")	
6.	150-772	1	CYLINDER HEAD (2" X 1")	
7.	150-417	1	CYLINDER ROD	

NOT SHOWN:

259-100	U-SEAL INSTALLER (1" - 1.499")
259-235	1.00 ROD WIPER TOOL
259-239	WIPER/SEAL INSTALLER (2")
259-241	PISTON INSTALLER (2")
259-188	CYL HEAD SPANNER - TWO PIN

FOOTNOTES

1 - TORQUE TO 90-100 FT-LBS (120-135 N.M).

HYDRAULIC CYLINDER

2.0" X 1.25" X 24.0"

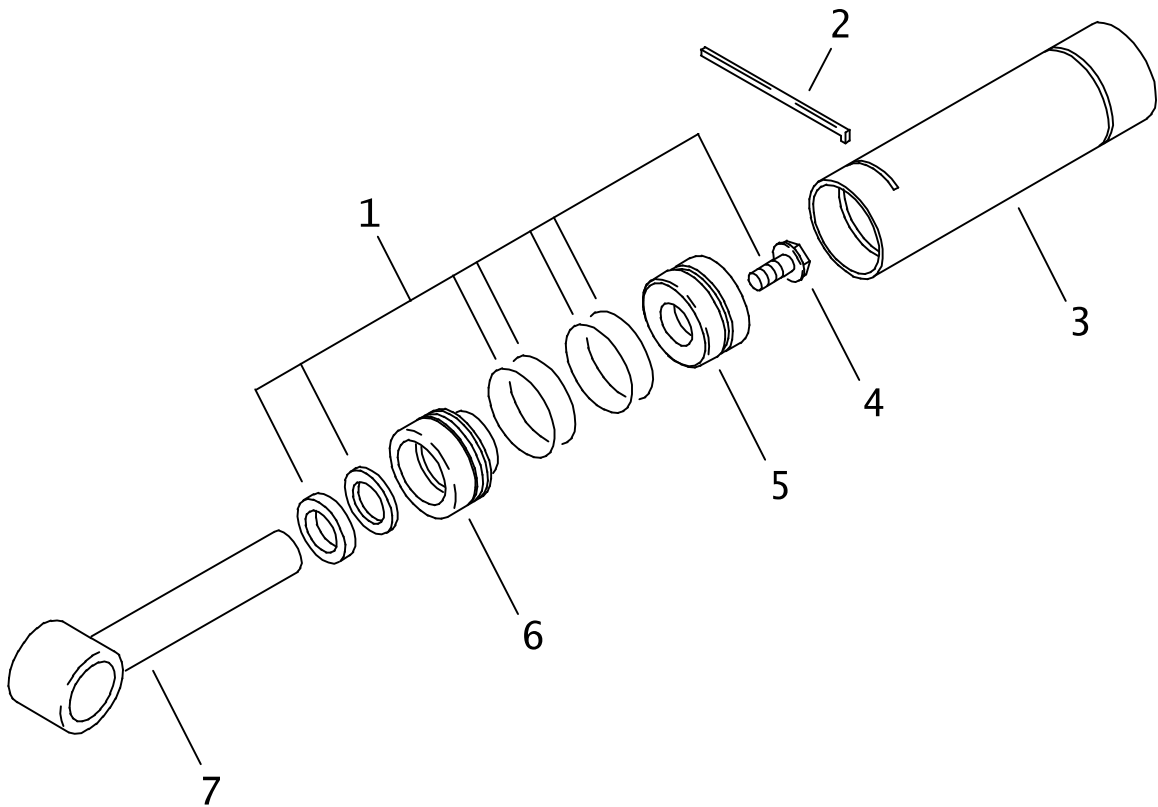

HYDRAULIC CYLINDER

2.0" X 1.25" X 24.0"

REF NO.	PART NUMBER	QTY	DESCRIPTION	REMARKS
	150-747		CYL (2" X 1.25" X 24")	INCLUDE REF NO.'S 1 THRU 7
1.	190-169	1	SEAL REPAIR KIT (2.0" X 1.25")	INCLUDES REF NO.'S 4 & 5
2.	150-778	1	LOCK RING (2")	
3.	151-170	1	CYLINDER BARREL	
4.	106-097	1	FLG BOLT (5/8-NC X 1-3/4", GD8)	SEE FOOTNOTE 1
5.	150-771	1	CYLINDER PISTON (2.0" X 1.25")	INCLUDES MOLDED-ON WEAR RING
6.	150-770	1	CYLINDER HEAD (2.0" X 1.25")	
7.	150-679	1	CYLINDER ROD (1.25")	

NOT SHOWN:

259-100	U-SEAL INSTALLER (1"-1.499")
259-236	WIPER INSTALLER (1.250")
259-239	WIPER/SEAL INSTALLER (2")
259-241	PISTON INSTALLER (2")
259-188	CYL HEAD SPANNER - TWO PIN

FOOTNOTES

1. APPLY LOCTITE 271 OR 277. TORQUE TO 180-200 FT-LBS (245-270 N.M.)

NOTE:

D

806-687

HYDRAULIC CYLINDER

3" X 1.75" X 8"

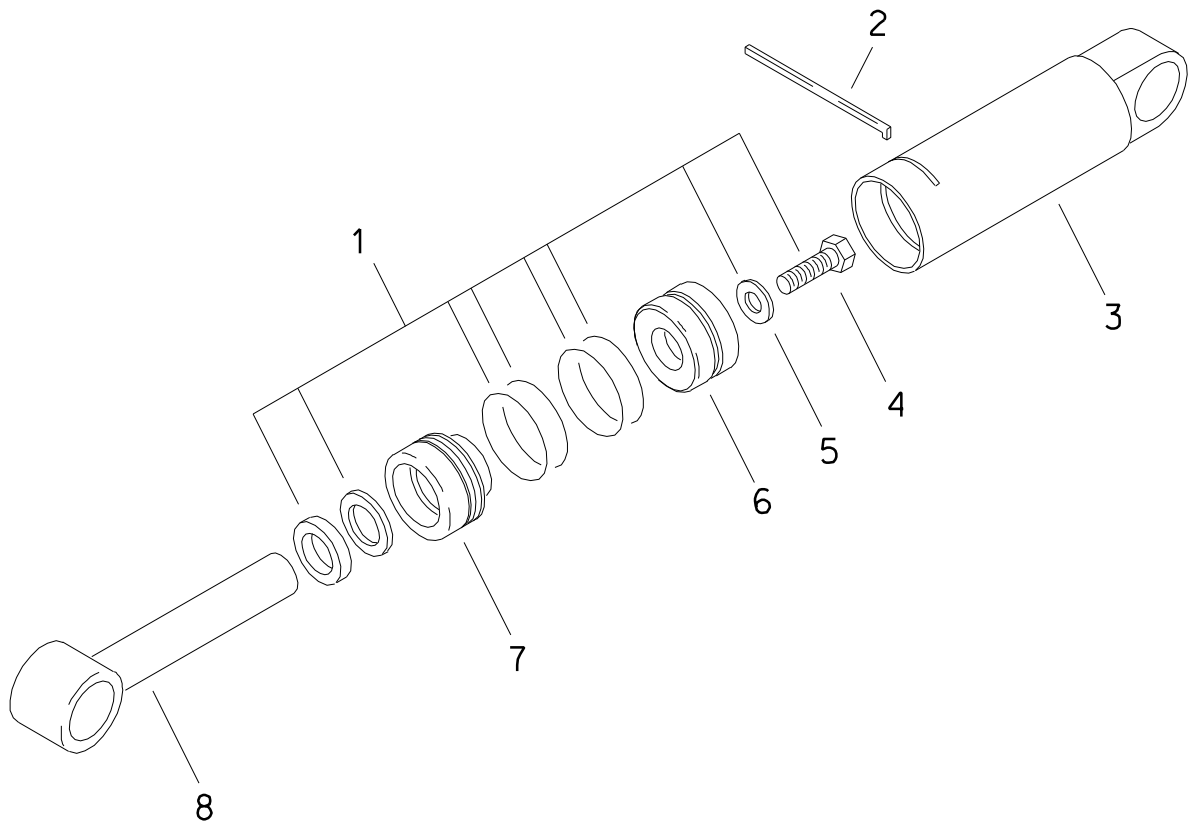

HYDRAULIC CYLINDER

3" X 1.75" X 8"

REF NO.	PART NUMBER	QTY	DESCRIPTION	REMARKS
	151-070		CYL (3.0" X 1.75" X 8.0")	INCL REF NO.'S 1 THRU 7
1.	190-172	1	SEAL REPAIR KIT (3.0" X 1.75")	INCL REF NO.'S 4 THRU 5
2.	150-911	1	LOCK RING (3")	
3.	152-014	1	CYLINDER BARREL (3")	
4.	106-122	1	BOLT (7/8-NC X 2-1/4", GD8)	SEE FOOTNOTE 1
5.	105-363	1	WASHER (7/8")	
6.	150-765	1	CYLINDER PISTON (3" X 1.75")	INCL MOLDED-ON WEAR RING
7.	150-763	1	CYLINDER HEAD (3" X 1.75")	
8.	150-436	1	CYLINDER ROD (1.75")	

NOT SHOWN:

- 259-040 U-SEAL INSTALLER (1.5" - UP)
- 259-238 WIPER INSTALLER (1.75")
- 259-065 PISTON SEAL INSTALLER (3")
- 259-066 PISTON INSTALLER (3")
- 259-188 CYL HEAD SPANNER - TWO PIN

FOOTNOTES

- 1. CLEAN & DRY THREADS. APPLY RED LOCTITE (RC 271 OR RC 272). TORQUE TO 410-460 FT-LBS (560-625 N.M.)

HYDRAULIC CYLINDERS (4.0" X 2.0")

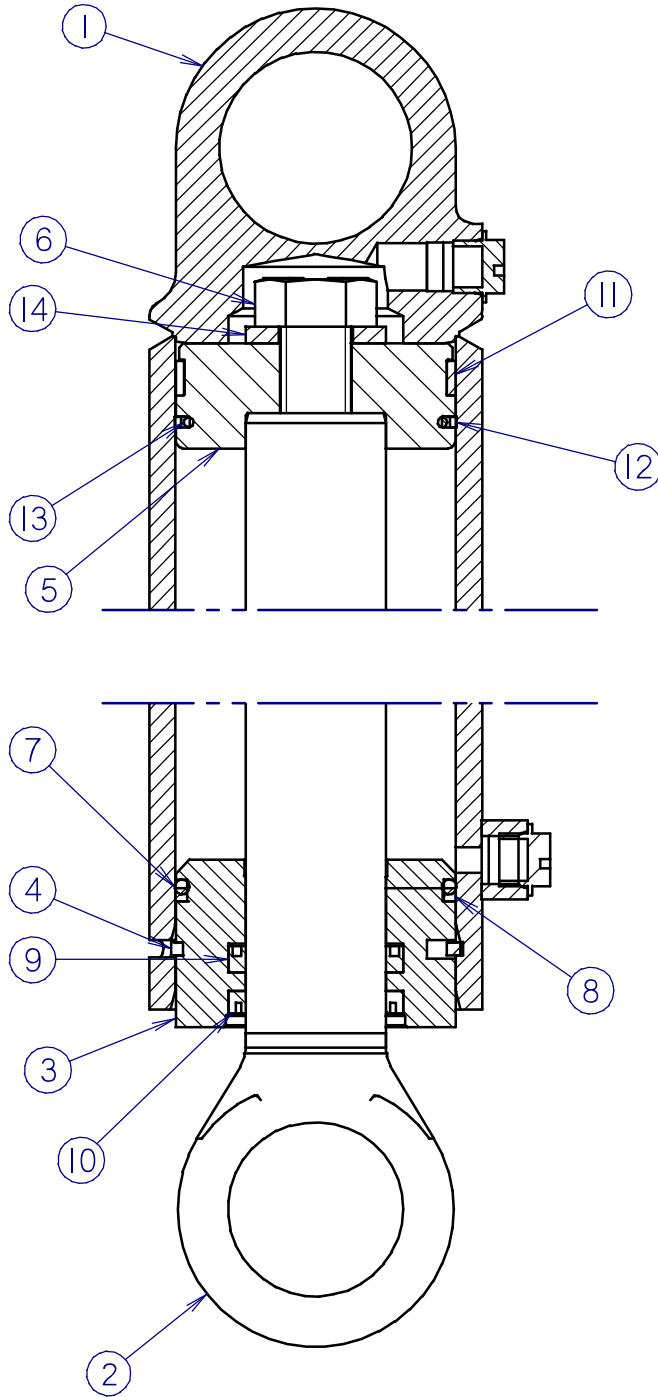

HYDRAULIC CYLINDERS (4.0" X 2.0")

REF NO.	PART NUMBER	QTY	DESCRIPTION	REMARKS
	149-698	-	CYL (4.0 X 2.0 X 4.0)	SEE FOOTNOTES 1 & 2
1	149-768	1	CYLINDER BARREL (4.0 X 4.0)	
2	153-021	1	CYLINDER ROD (2.00 X 4.0)	
	151-066	-	CYL (4.0 X 2.0 X 5.0)	SEE FOOTNOTES 1 & 2
1	152-012	1	CYLINDER BARREL (4.0 X 5.0)	
2	150-440	1	CYLINDER ROD (2.00 X 5.0)	
	149-699	-	CYL (4.0 X 2.0 X 6.0)	SEE FOOTNOTES 1 & 2
1	152-062	1	CYLINDER BARREL (4.0 X 6.0)	
2	149-735	1	CYLINDER ROD (2.00 X 6.0)	
	149-700	-	CYL (4.0 X 2.0 X 8.0)	SEE FOOTNOTES 1 & 2
1	152-030	1	CYLINDER BARREL (4.0 X 8.0)	
2	149-736	1	CYLINDER ROD (2.00 X 8.0)	
	149-701	-	CYL (4.0 X 2.0 X 10.0)	SEE FOOTNOTES 1 & 2
1	149-769	1	CYLINDER BARREL (4.0 X 10.0)	
2	153-016	1	CYLINDER ROD (2.00 X 10.0)	
	151-088	-	CYL (4.0 X 2.0 X 12.0)	SEE FOOTNOTES 1 & 2
1	150-298	1	CYLINDER BARREL (4.0 X 12.0)	
2	150-429	1	CYLINDER ROD (2.00 X 12.0)	
	149-702	-	CYL (4.0 X 2.0 X 16.0)	SEE FOOTNOTES 1 & 2
1	152-007	1	CYLINDER BARREL (4.0 X 16.0)	
2	149-737	1	CYLINDER ROD (2.00 X 16.0)	
	149-703	-	CYL (4.0 X 2.0 X 20.0)	SEE FOOTNOTES 1 & 2
1	149-770	1	CYLINDER BARREL (4.0 X 20.0)	
2	149-738	1	CYLINDER ROD (2.00 X 20.0)	
	149-704	-	CYL (4.0 X 2.0 X 24.0)	SEE FOOTNOTES 1 & 2
1	152-063	1	CYLINDER BARREL (4.0 X 24.0)	
2	149-739	1	CYLINDER ROD (2.00 X 24.0)	
3	149-006	1	CYLINDER HEAD (4.0 X 2.00)	
4	149-303	1	LOCK RING (4.0)	
5	149-307	1	CYLINDER PISTON (4.0 X 2.00)	
6	106-145	1	BOLT (1-NC X 2-1/4", GD8)	SEE FOOTNOTE 3
7	157-035	1	O-RING (342 D90)	
8	157-036	1	BACKUP RING (342 D90)	
9	157-559	1	U-SEAL (2.000")	
10	157-558	1	WIPER SEAL (2.000")	
11	125-793	1	WEAR RING	
12	157-570	1	BACKUP RING (238 D90)	
13	157-044	1	O-RING (238 D90)	
14	106-144	1	WASHER (1")	

FOOTNOTES

- REF. #1 & #2 ARE SPECIFIC TO EACH CYLINDER, REF. #3 THRU #14 ARE COMMON FOR ALL THE ABOVE LISTED CYLINDERS.
- SEAL REPAIR KIT P/N: 190-189
- APPLY LOCTITE 277 OR EQUIVALENT, TORQUE TO 630-700 FT-LBS

NOT SHOWN:

- 259-040 U-SEAL INSTALLER (1.5" - UP)
- 259-239 WIPER/SEAL INSTALLER (2")
- 259-246 PISTON SEAL INSTALLER (4")
- 259-247 PISTON INSTALLER (4")
- 259-188 CYL HEAD SPANNER - TWO PIN

A

809-369

HYDRAULIC CYLINDER (4.0" X 2.00" X 10.0")

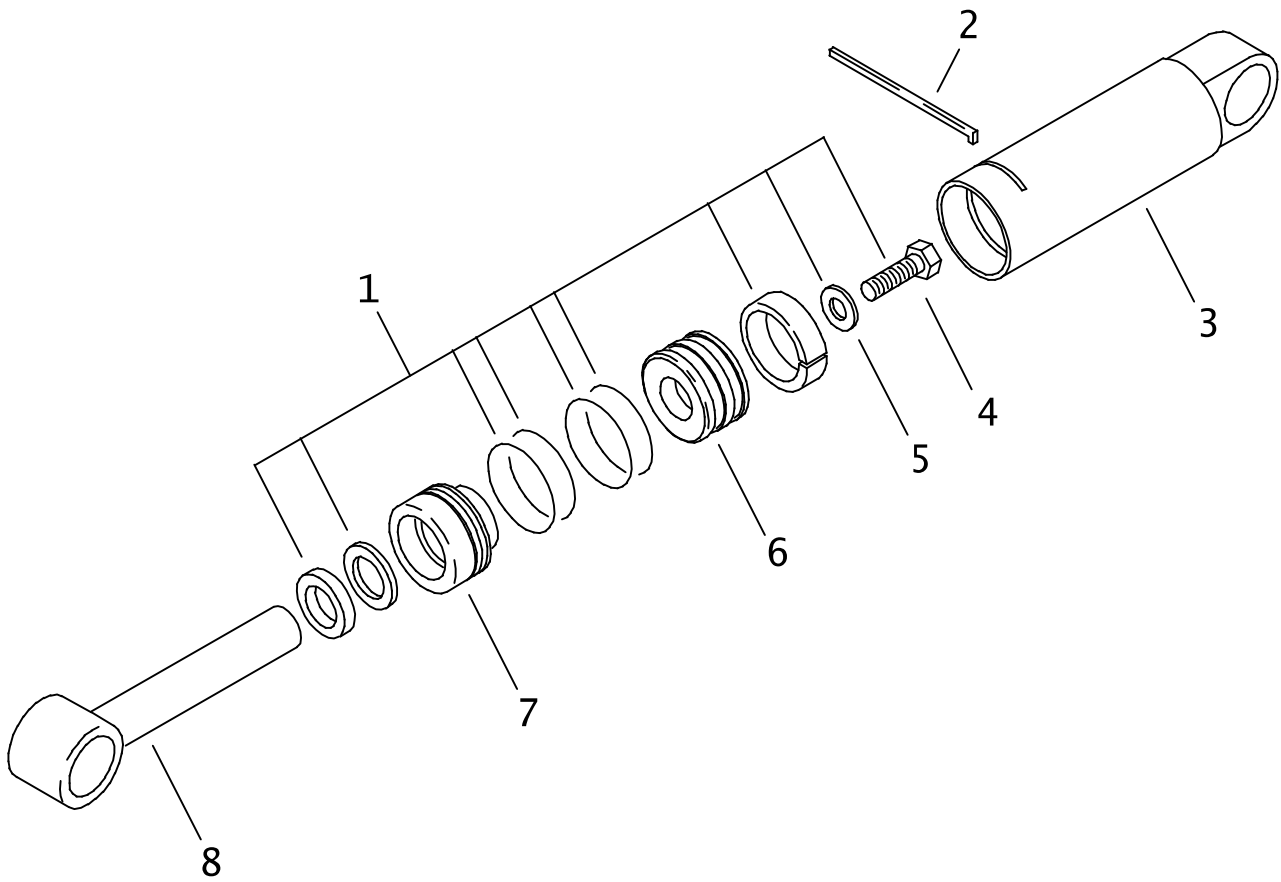

HYDRAULIC CYLINDER (4.0" X 2.00" X 10.0")

REF NO.	PART NUMBER	QTY	DESCRIPTION	REMARKS
	151-187		CYLINDER ASSEMBLY	INCLUDES REF NO.'S 1 THRU 7
1.	190-189	1	SEAL REPAIR KIT (4.0" X 2.0")	INCLUDES REF. NO.'S 4 & 5
2.	149-303	1	LOCK RING (4")	
3.	152-071	1	CYLINDER BARREL	
4.	106-145	1	BOLT (1-NC X 2-1/4", GD8)	SEE FOOTNOTE 1
5.	106-144	1	WASHER (1")	
6.	149-307	1	CYLINDER PISTON (4" X 2")	
7.	149-006	1	CYLINDER HEAD (4" X 2")	
8.	153-016	1	CYLINDER ROD	

NOT SHOWN:

259-040	U-SEAL INSTALLER (1.500"-UP)
259-239	WIPER/SEAL INSTALLER (2")
259-246	PISTON SEAL INSTALLER (4")
259-247	PISTON INSTALLER (4")
259-188	CYL HEAD SPANNER - TWO PIN

FOOTNOTES

1 APPLY LOCTITE 271 OR 277. TORQUE TO 630-700 FT-LBS (855-950 NM)

NOTE:

D

806-688

NOTES:

ELECTRICAL

RIGHT CONSOLE

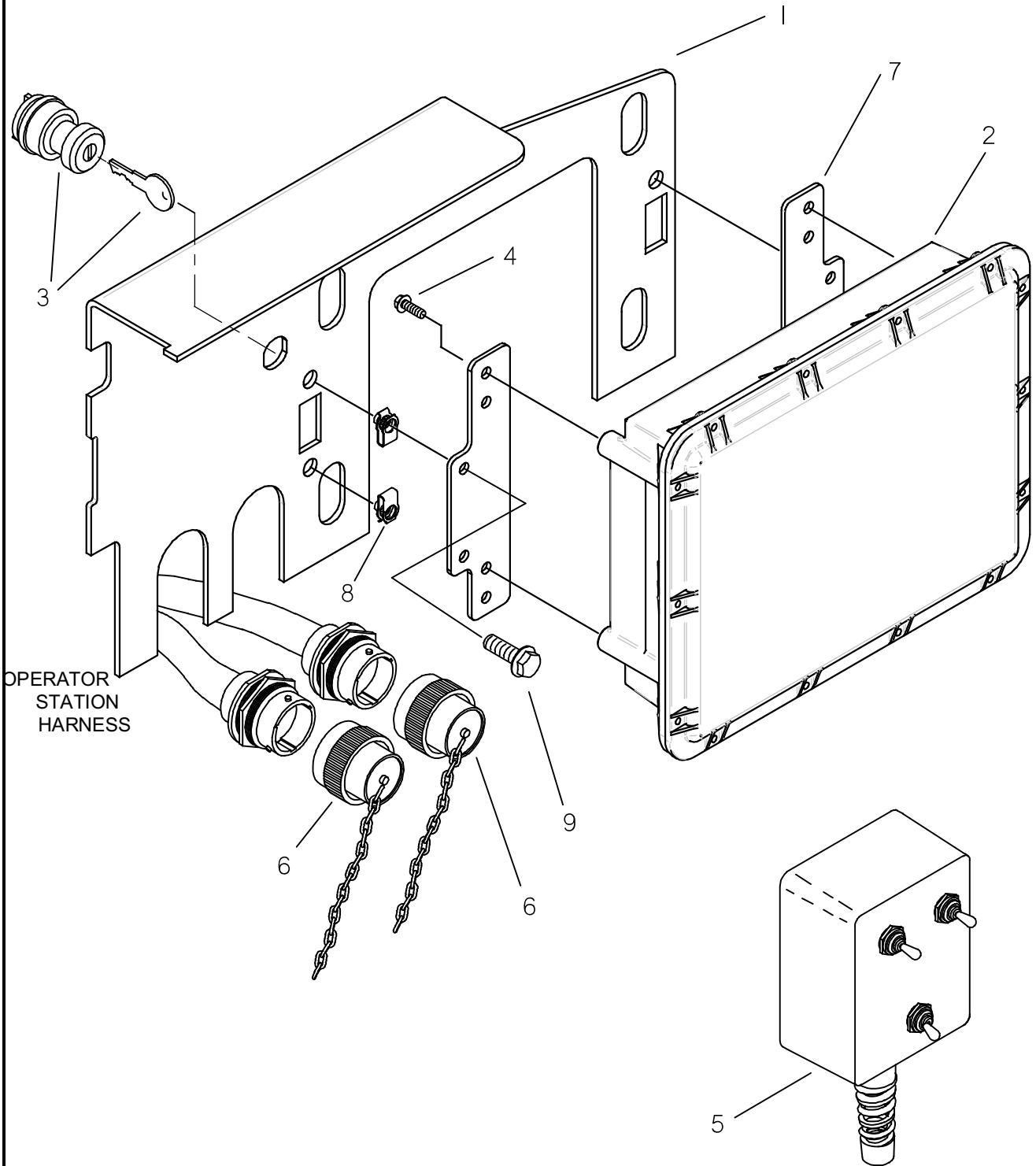

RIGHT CONSOLE

REF NO.	PART NUMBER	QTY	DESCRIPTION	REMARKS
1.	313-733	-	OPERATOR FRAME	
2.	220-1023	-	JT CONTROLLER 2	
3.	214-908	-	OFF-ON KEY SWITCH	
4.	106-378	4	FLG LK SCREW (M6-1.00 X 12MM)	
5.	214-648	1	OVERRIDE CONTROL BOX	
6.	214-812	2	PROTECTIVE CAP	
7.	316-791	2	MOUNTING BRACKET	
8.	106-574	3	CLIP NUT (M6-1.00)	
9.	106-988	3	FLG LK SCREW (M6-1.00 X 20MM)	

NOT SHOWN:

FOOTNOTES:

NOTE:

BATTERY

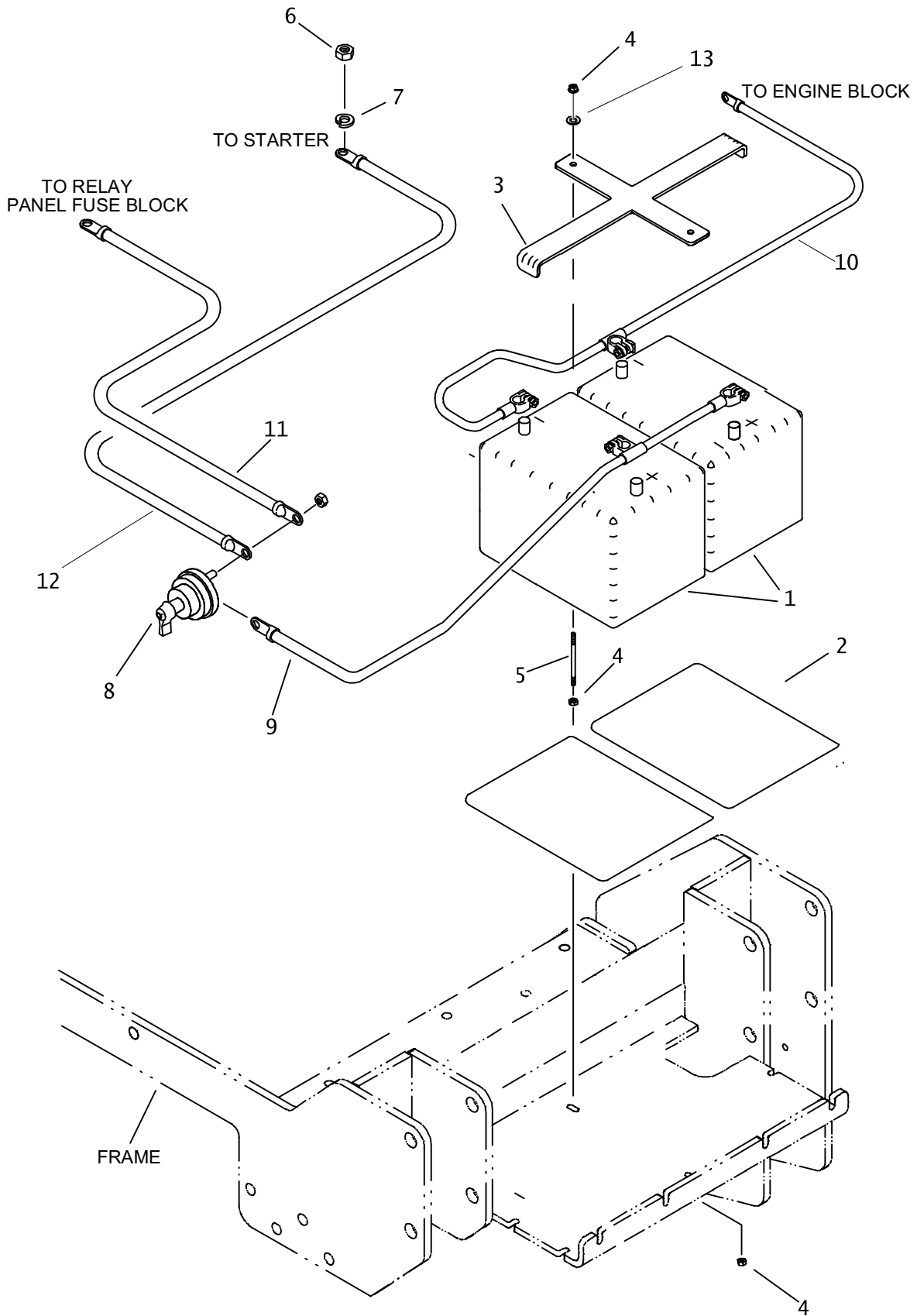

BATTERY

REF NO.	PART NUMBER	QTY	DESCRIPTION	REMARKS
1.	215-262	2	BATTERY (12V, 925 AMP)	
2.	116-717	2	BATTERY PAD	
3.	347-857	1	DUAL BATTERY STRAP	
4.	106-154	6	FLG LOCKNUT (1/4-NF)	
5.	361-484	2	BRAKE ROD	
6.	105-044	1	JAM NUT (1/2-NC)	
7.	105-070	1	LOCK WASHER (1/2").	
8.	217-819	1	BAT DISCONNECT SWITCH	
9.	215-1106	1	BATTERY CABLE	
10.	215-1096	1	BATTERY CABLE	
11.	215-1098	1	PRIMARY CABLE	
12.	215-1095	1	BATTERY CABLE	
13.	106-076	2	WASHER (1/4")	

NOT SHOWN:

FOOTNOTES:

NOTE:

PANEL

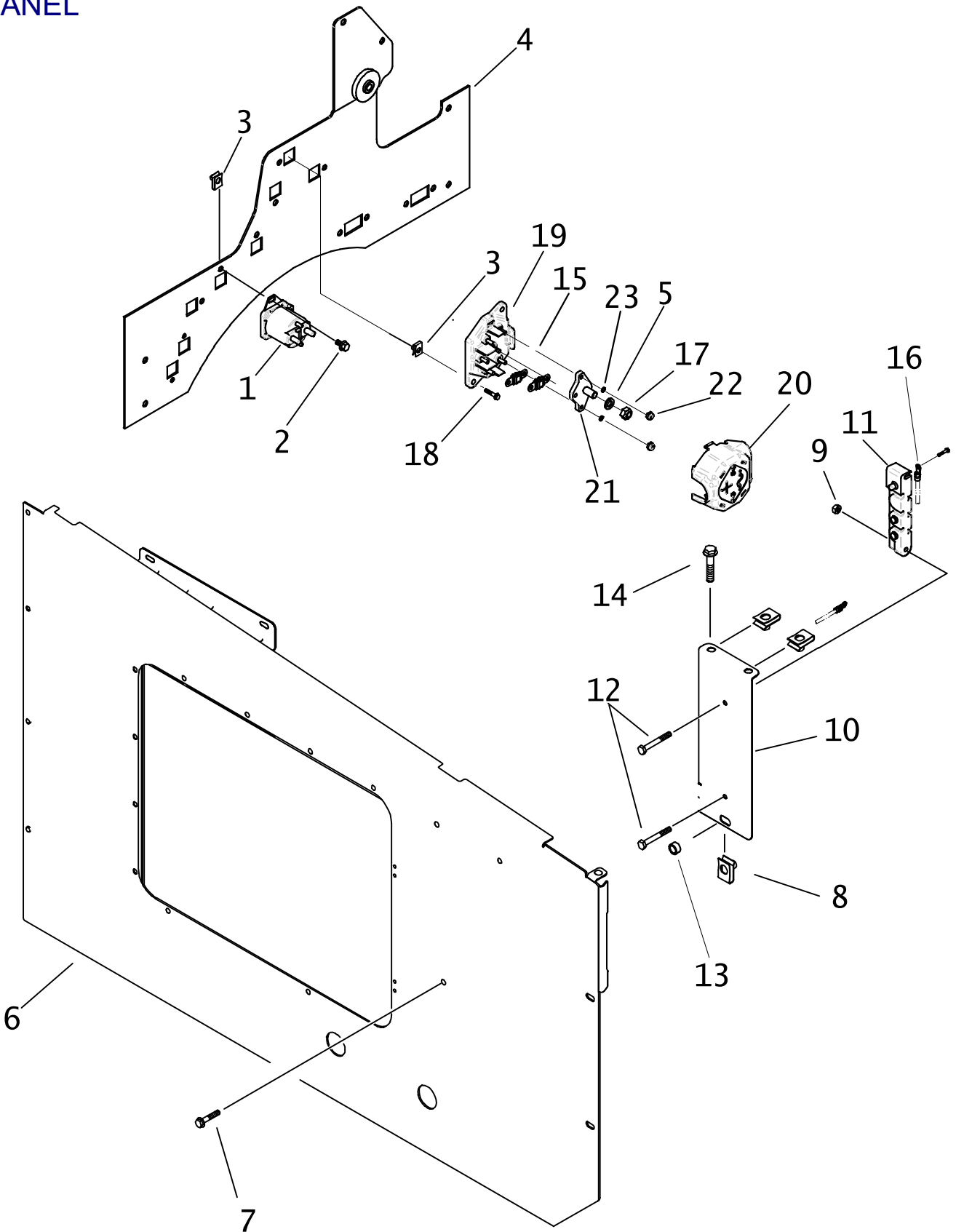

PANEL

REF NO.	PART NUMBER	QTY	DESCRIPTION	REMARKS
1.	214-979	1	PREHEATER SOLENOID (12V)	
2.	106-986	2	FLG LK SCREW (M6-1.00 X 12mm)	
3.	106-574	4	CLIP NUT (M6-1.00)	
4.	300-1762	1	FIREWALL	
5.	105-072	1	LOCKWASHER (3/8")	
6.	310-448	1	FRONT ENGINE PANEL (RIGHT)	
7.	106-992	1	FLG LK SCREW (M8-1.25 X 25mm)	
8.	106-551	3	CLIP NUT (M8-1.25)	
9.	106-106	2	NUT (M6-1.00)	
10.	320-996	1	J-BOX MOUNT	
11.	213-359	1	CAN WITCH/J 1939 J-BOX	
	105-214	1	FLG SCREW (#10-24 X 1/2")	
12.	107-025	2	SCREW (M6-1.00 X 50mm)	
13.	184-870	1	SPACER	
14.	106-991	2	FLG LK SCREW (M8-1.25 X 20mm)	
15.	211-305	2	BK/AMI 125 AMP FUSE	
16.	213-146	1	8" GROUND STRAP	
17.	105-053	1	NUT (3/8-NC)	
18.	106-987	2	FLG LK SCREW (M6-1.00 X 16mm)	
19.	215-1009	1	MAIN FUSE HOLDER BASE	
20.	215-1010	1	MAIN FUSE HOLDER COVER	
21.	215-1011	1	BUSS BAR (MAIN FUSE HOLDER)	
22.	105-186	4	NUT (#10-24)	
23.	106-056	2	EXT STAR WASHER (#10)	

NOT SHOWN:

FOOTNOTES:

NOTE:

ALARM AND STROBE LIGHT ELECTRICAL STRIKE SYSTEM

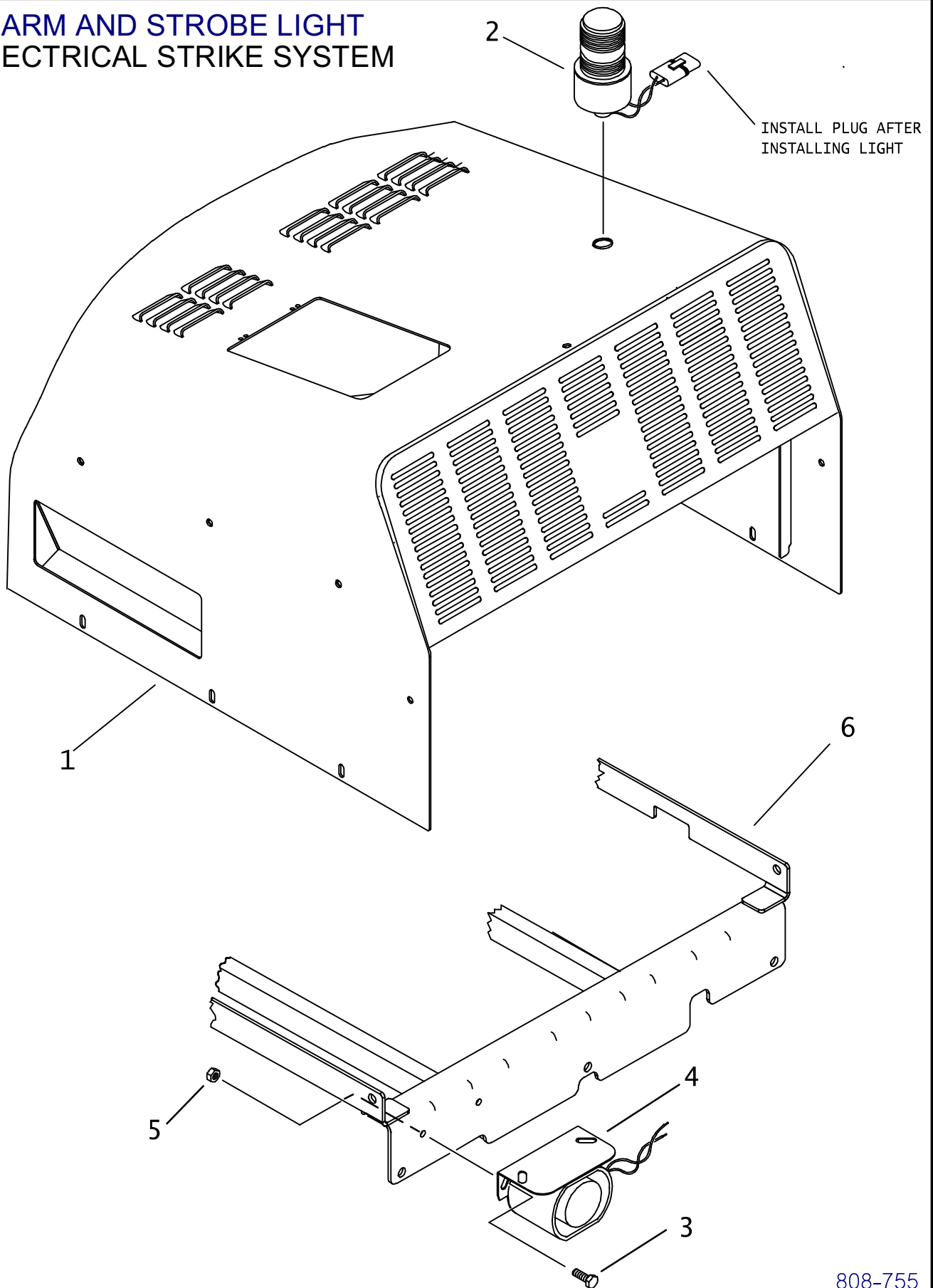

D

808-755

ALARM AND STROBE LIGHT ELECTRICAL STRIKE SYSTEM

REF NO.	PART NUMBER	QTY	DESCRIPTION	REMARKS
1.	320-838	-	ENGINE PANEL (TOP)	
2.	217-296	1	STROBE LIGHT AMBER MED PROFILE	
3.	106-162	2	FLG SCREW(M8-1.25 X 20MM, GD8)	
4.	306-602	1	BACKUP ALARM	
5.	106-561	2	LOCKNUT (M8-1.25,PRV TRQ,10.9)	
6.	320-849	-	ENGINE SKID	

FOOTNOTES

NOTE:

D

808-755

RELAY PANEL

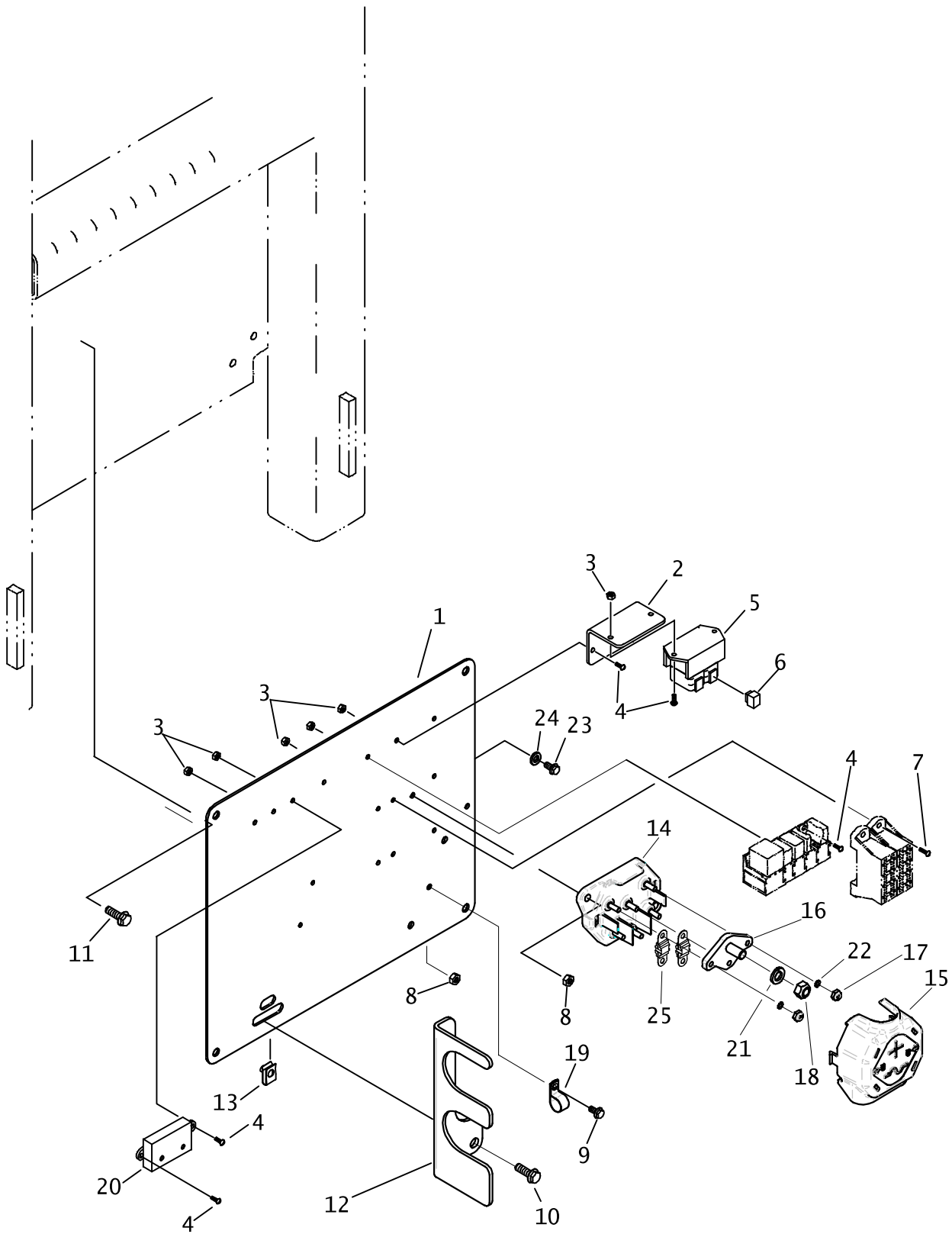

RELAY PANEL

REF NO.	PART NUMBER	QTY	DESCRIPTION	REMARKS
1.	324-997	1	RELAY PANEL	
2.	310-981	1	BRACKET	
3.	106-048	12	LOCKNUT (#10-24)	
4.	105-185	8	BOLT (#10-24 X 1/2", RD SLT)	
5.	211-026	1	DIODE PACK (DEUTSCH)	
6.	214-781	1	12-WAY PLUG	
7.	106-049	6	BOLT (#10-24 X 3/4", PLPS)	
8.	106-237	3	LOCKNUT 9M6-1.00, PRV TRQ, NLK	
9.	106-378	1	BOLT (M6 -1.00 X12MM)	
10.	107-095	1	FLG SCREW (M8-1.25 X 16MM)	
11.	106-991	4	FLG LK SCREW (M8-1.25 X 20MM)	
12.	300-2029	1	HARNESS BRACKET	
13.	106-551	1	CLIP NUT (M8-1.25)	
14.	215-1009	1	MAIN FUSE HOLDER BASE	
15.	215-1010	1	MAIN FUSE HOLDER COVER	
16.	215-1011	1	BUSSBAR (MAIN FUSE HOLDER)	
17.	105-186	2	NUT (#10-24)	
18.	105-053	1	NUT (3/8-NC)	
19.	110-333	1	BOLT-ON CLAMP (1")	
20.	215-1093	1	POWER RELAY	
21.	105-072	1	LOCKWASHER (3/8")	
22.	106-056	2	EXT STAR WASHER (#10)	
23.	106-987	2	FLG LK SCREW (M6-1.00 X 16MM)	
24.	106-076	2	WASHER (1/4")	
25.	211-305	2	BK/AMI 125AMP FUSE	

NOT SHOWN:

FOOTNOTES:

NOTE:

CONTROLLER J-BOX

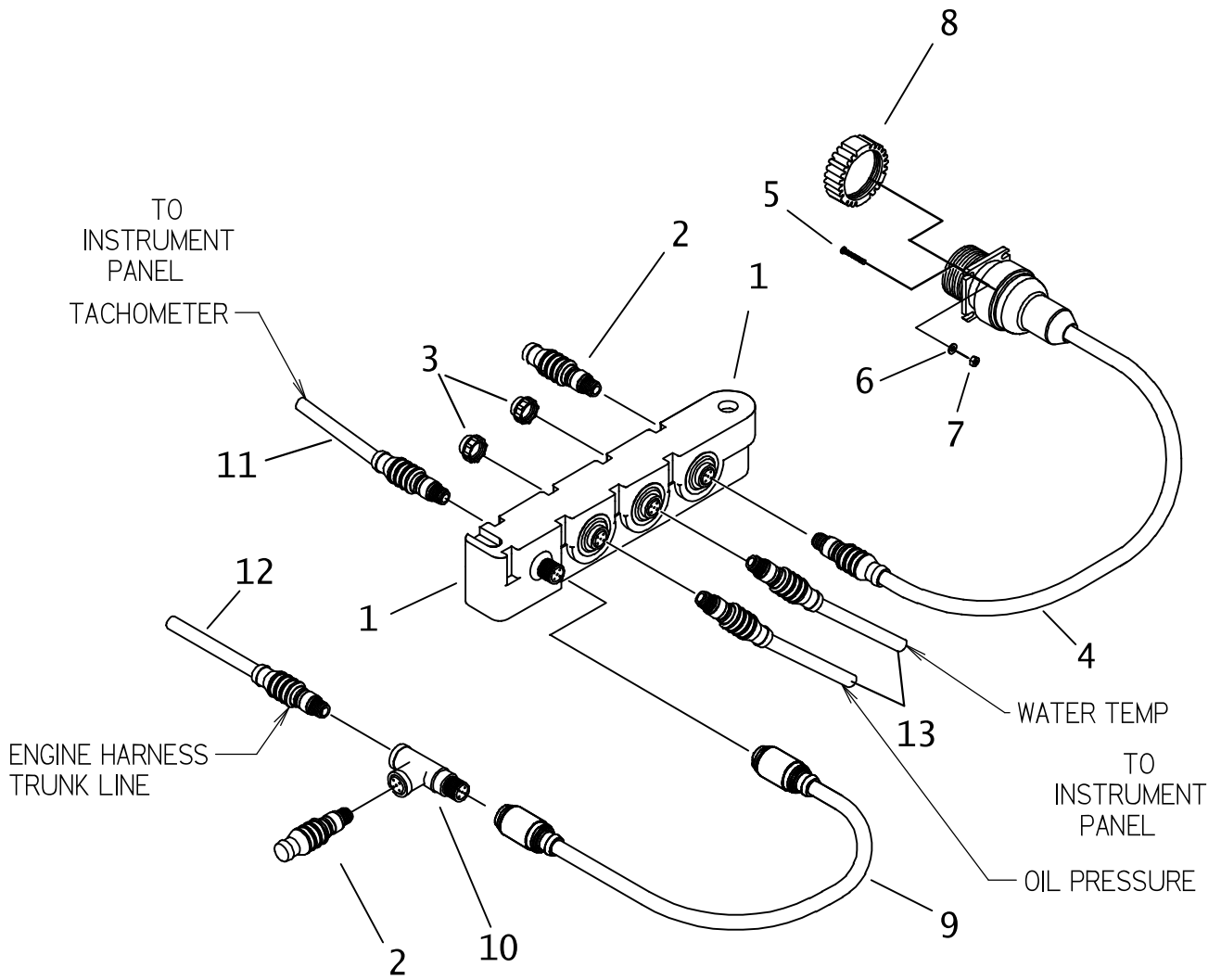

CONTROLLER J-BOX

REF NO.	PART NUMBER	QTY	DESCRIPTION	REMARKS
1.	213-359	1	CAN WITCH/J1939 J-BOX)	
2.	215-1063	2	CAN RESISTOR	
3.	211-078	1	CONNECTOR CAP (TURCK RS-CC)	
4.	215-1027	1	CAN DIAGNOSTIC HARNESS	
5.	107-269	4	SCREW (#4-40 Xf", PAN)	
6.	106-279	4	WASHER, FLAT, #4, BRS	
7.	106-277	4	NUT, (#4-40 BRASS)	
8.	213-035	1	DUST CAP W/ LANYARD	
9.	215-1067	1	CAN CABLE	
10.	215-1062	1	CAN TEE	
11.	215-1073	1	CAN TACH HARNESS	
12.	215-1021	-	ENGINE HARNESS	
13.	215-1028	2	CAN GAUGE HARNESS	

NOT SHOWN:

FOOTNOTES:

NOTE:

NOTES:

ACCESSORIES

DRILLING FLUID TRANSFER

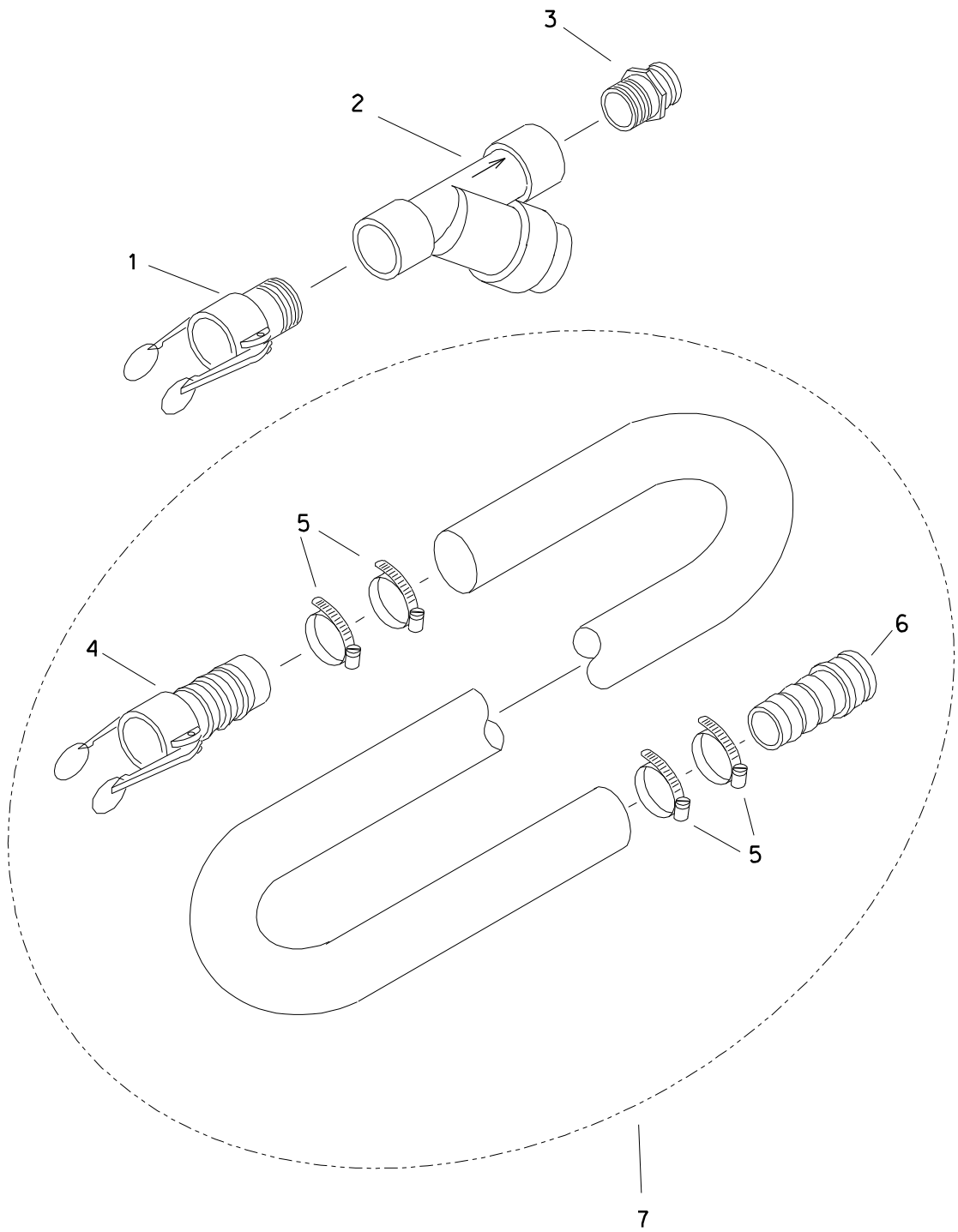

DRILLING FLUID TRANSFER

REF NO.	PART NUMBER	QTY	DESCRIPTION	REMARKS
	153-371		Y-STRAINER PARTS ASS'Y	INCL REF NO'S 1 - 3
1.	514-386	1	FHC BODY (3-1/2" FHC X 3"NPT)	
2.	159-439	1	Y-STRAINER (48NF)	
	159-490	-	STRAINER (4" X 9")	
	165-895	-	O-RING (END CAP)	
	111-083	-	END CAP	
	308-651	-	END CAP CLAMP	
3.	155-263	1	FHC ADAPTER (56-48N)	
4.	155-264	-	FHC BODY (56-48H)	USE TO REPAIR 153-358
5.	110-367	-	WORM CLAMP (3.250" TO 4.125")	USE TO REPAIR 153-358
6.	153-341	-	FHC ADAPTER (56-48H)	USE TO REPAIR 153-358
7.	153-358	-	TRANSFER HOSE (3" FHC, 50')	USE REF NO'S 4 - 6 TO REPAIR

FOOTNOTES

FLUID MIXING ACCESSORIES

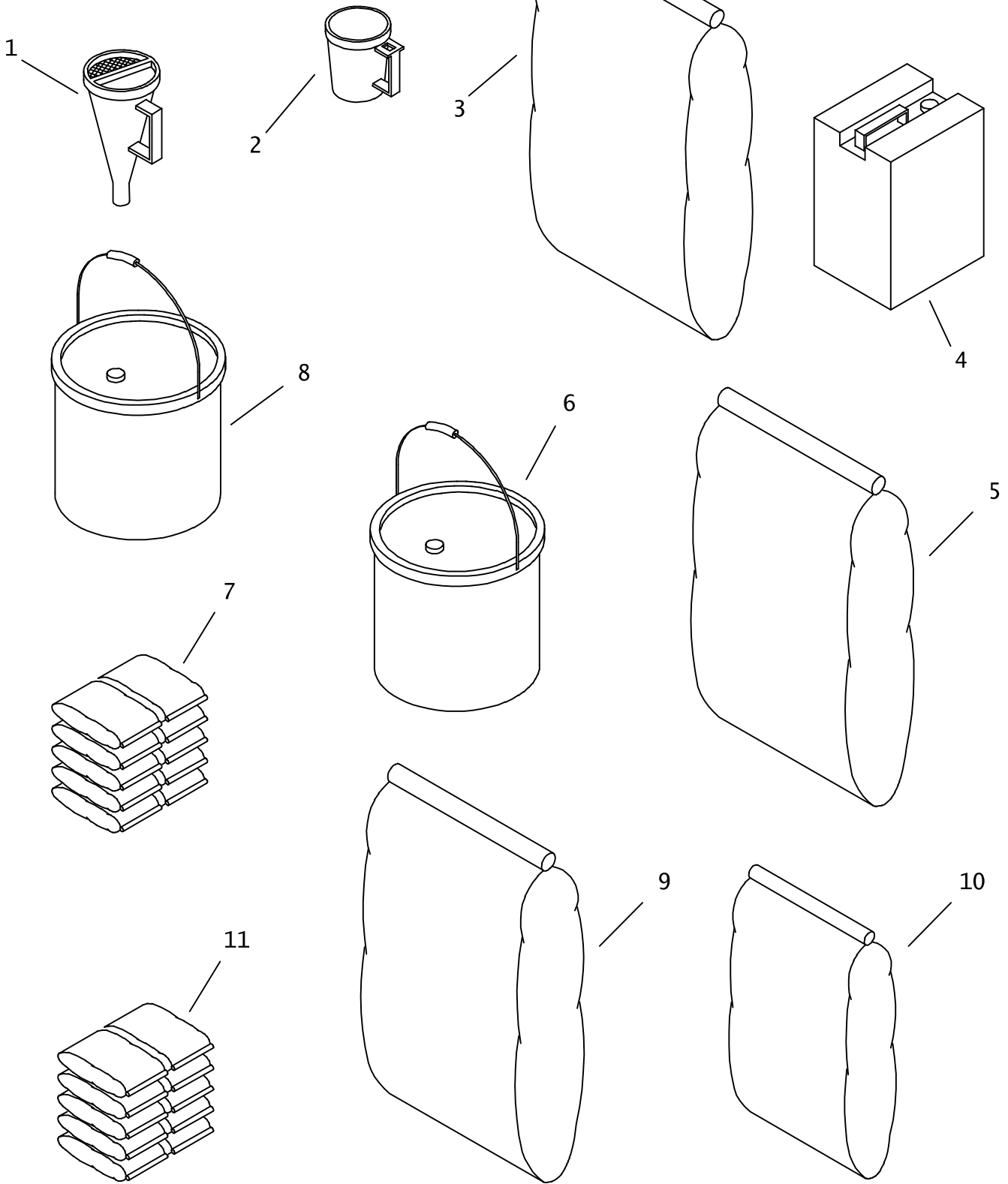

FLUID MIXING ACCESSORIES

REF NO.	PART NUMBER	QTY	DESCRIPTION	REMARKS
1.	259-195	1	VISCOSITY FUNNEL	
2.	259-196	1	VISCOSITY CUP	
3.	259-804	AR	BENTONITE, QUIK-GEL (50 LB)	
4.	259-805	AR	LIQUID POLYMER, EZ-MUD (5 GAL)	
5.	259-807	AR	BENTONITE, BORE-GEL (50 LB)	
6.	259-808	AR	VISCOSIFIER, LIQUI-TROL (5 GAL)	
7.	259-809	AR	POWDER POLYMER, QUIK-TROL (20 LB)	
8.	259-810	AR	WET AGENT, CON-DET (5 GAL)	
9.	259-821	AR	'PAC-R' FILTRATION CONTROL	
10.	259-822	AR	'BARAZAN D+' VISCOSIFIER	
11.	259-832	AR	'NO SAG' (20# BOX/10-2#BAGS)	

NOT SHOWN:

191-158	1	DRILLING FLUID TEST KIT
259-487	1	SHEAROMETER

FOOTNOTES:

NOTE:

HEATED HOSE KIT

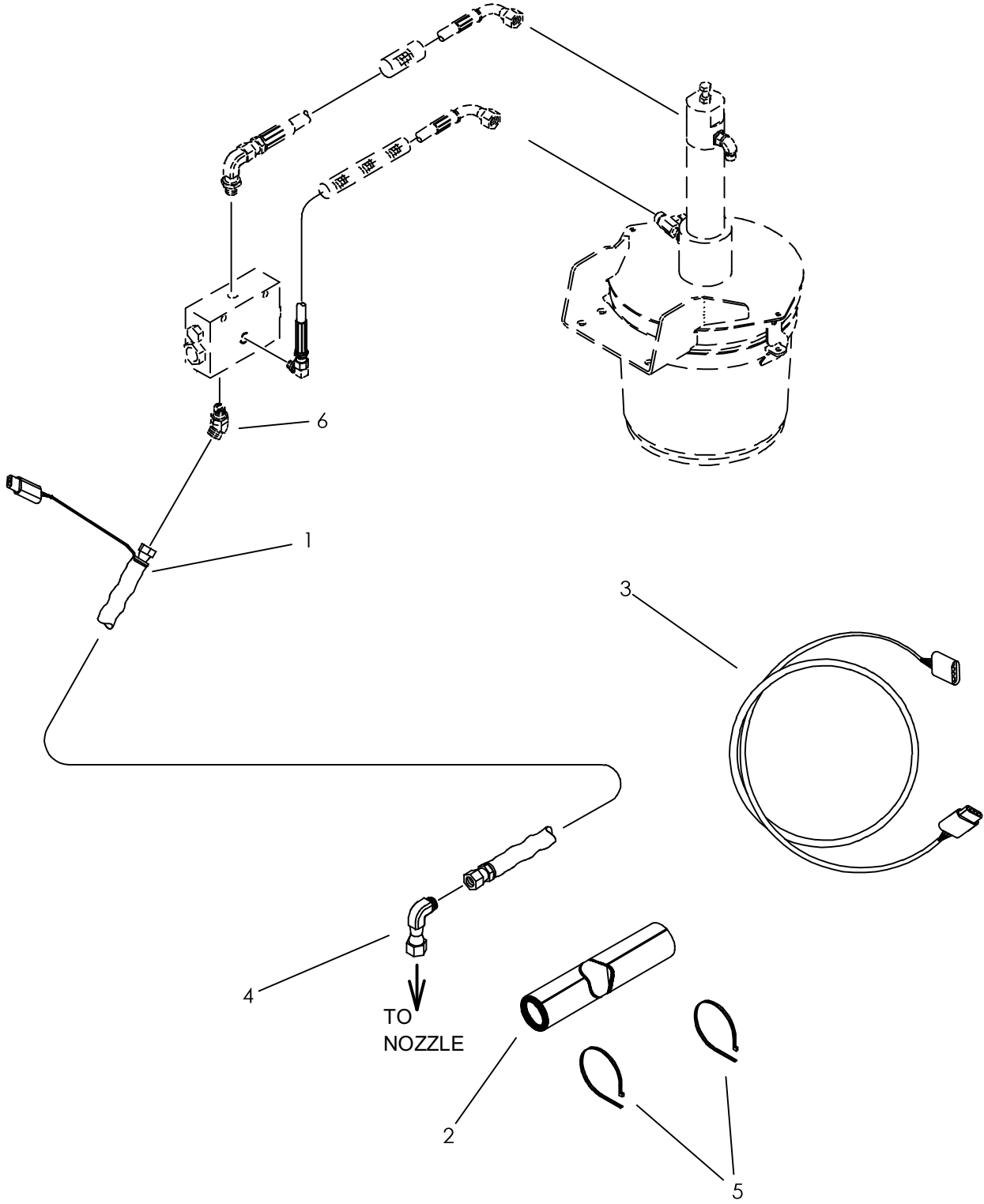

HEATED HOSE KIT

REF NO.	PART NUMBER	QTY	DESCRIPTION	REMARKS
	101-088		JT27M1 HEATED HOSE KIT	USE REF.'S 1, 2, 3, & 5
	101-089		HEATED HOSE KIT	USE REF.'S 1, 2, 4, & 5
1.	153-585	1	HOSE (060FX-18"-3000,SPCL)	
2.	117-549	1	INSULATOR (1" ID X 5.00")	
3.	214-843	1	GREASER JUMPER HARNESS	USED ON JT2720 MACH 1 ONLY
4.	154-228	1	UNION (060-060FX90)	USED ON JT1720 MACH 1 & JT4020 MACH 1 ONLY
5.	110-030	4	CABLE TIE (1/16" TO 4")	
6.	154-224	1	CONNECTOR (06S-06045)	

NOT SHOWN:

FOOTNOTES:

NOTE:

REFERE TO INSTALLATION INSTRUCTION 05I-29I.

WORKING LIGHT

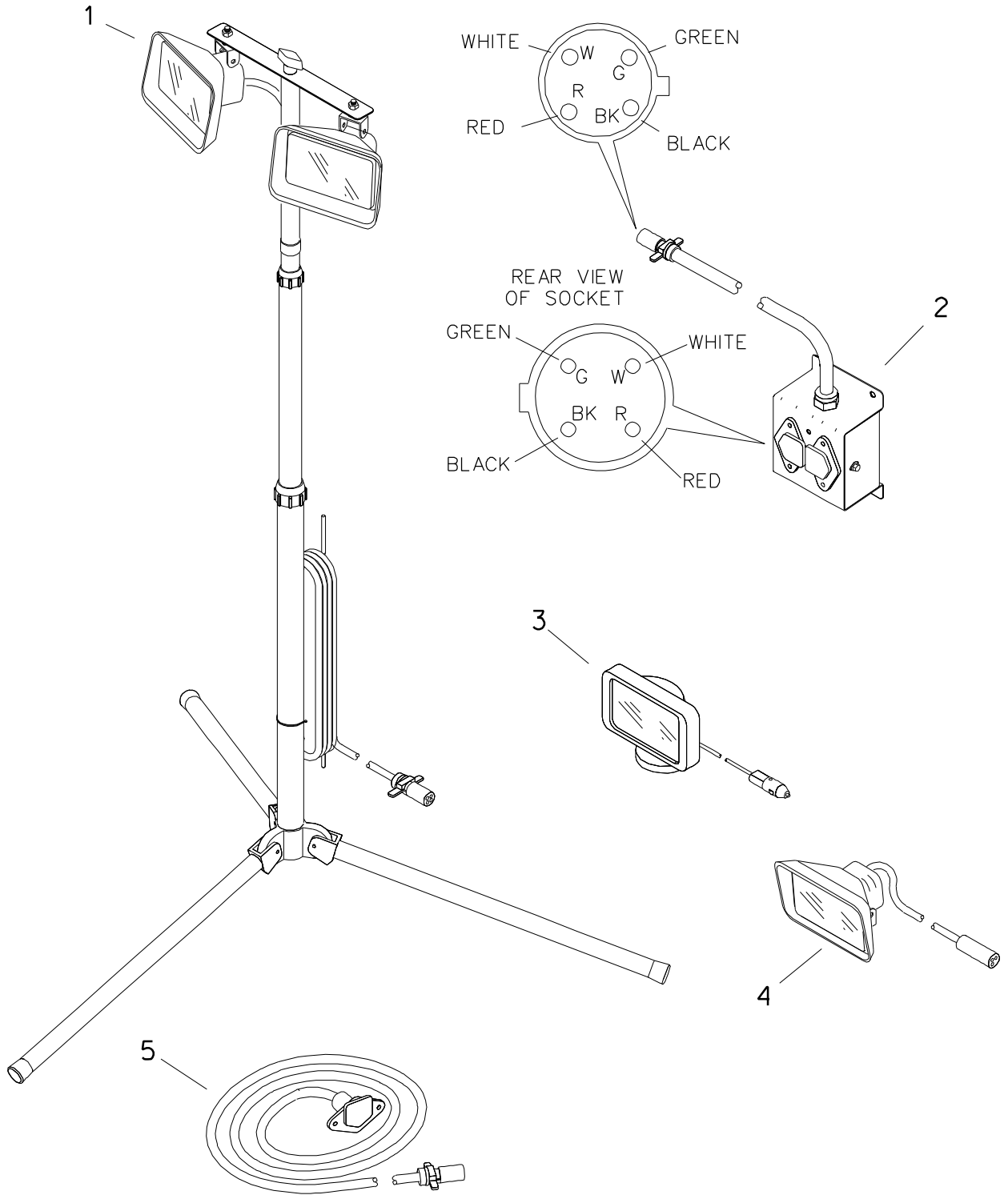

WORKING LIGHT

REF NO.	PART NUMBER	QTY	DESCRIPTION	REMARKS
1.	190-663	1	WORKING LIGHT CONVERSION KIT	INCL TRIPOD
	217-084	-	TRIPOD	
	217-094	1	DUAL LIGHT CABLE	
	217-080	2	WORKING LAMP (12V DC)	RECTANGULAR, MULTI-PURPOSE
	214-228	2	LIQUID-TIGHT FITTING	
	106-176	2	CONDUIT LOCKNUT (Ø8N)	
	110-373	1	BOLT-ON CLAMP (13/16")	
	106-162	1	FLG SCREW (M8-1.25 X 20mm)	
	106-386	1	FLG LOCKNUT (M8-1.25)	
	347-832	1	BRACKET (LIGHT KIT)	
	110-030	1	CABLE TIE (1/16" TO 4")	
	110-259	1	BOLT-ON CLAMP (.625")	
2.	190-664	1	LIGHT BOX KIT	
	347-833	1	LIGHT JUNCTION BOX	
	347-836	1	BACK PLATE	
	214-229	1	LIGHT HARNESS	JUNCTION BOX
	217-040	3	CONNECTOR (4-WAY, FM)	
	217-039	1	INDICATOR LIGHT (RED)	
	106-379	10	FLG LK SCREW (M6-1.00 X 20mm)	
	106-106	6	NUT (M6-1.00)	
	106-754	4	WELD NUT (M10-1.50)	
3.	217-098	1	WORK LAMP {12V DC, MAGNETIC}	
4.	190-665	1	LIGHT KIT (SINGLE)	
	217-080	1	WORKING LAMP (12V DC)	RECTANGULAR, MULTI-PURPOSE
	217-092	1	SINGLE LIGHT CABLE	
	214-228	1	LIQUID-TIGHT FITTING	
	106-176	1	CONDUIT LOCKNUT (Ø8N)	
5.	217-096	1	EXTENSION CABLE (30M {100'})	

FOOTNOTES

GROUNDING HARDWARE

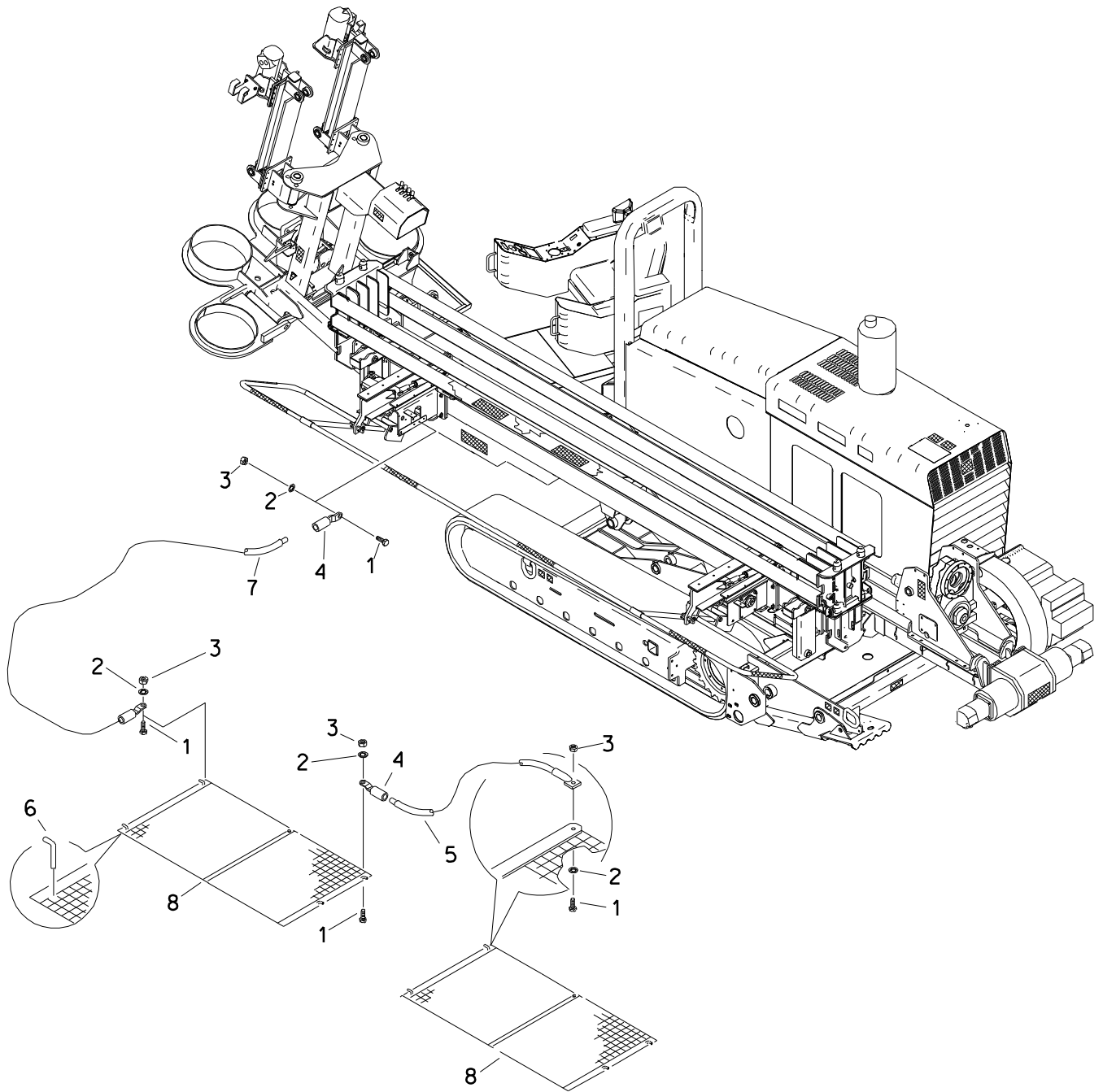

GROUNDING HARDWARE

REF NO.	PART NUMBER	QTY	DESCRIPTION	REMARKS
	100-074	-	STRIKE MAT KIT	INCL REF NO'S 1-8
1.	106-217	4	BOLT (1/4-NC X 1", SIL BRZ)	
2.	106-221	4	INT STAR WASHER (1/4", SIL BRZ)	
3.	106-455	4	LOCKNUT (1/4-NC, SIL BRZ)	
4.	215-771	2	GROUND RECEPTACLE (.3125" FM)	
5.	215-827	1	GROUND CABLE (6 GA X 6' M-EYE)	
6.	183-658	8	MAT STAKE	
7.	215-790	1	GROUND CABLE (6GA X 20' M-EYE)	
8.	215-824	2	GRID (6')	

FOOTNOTES

VANDAL COVERS

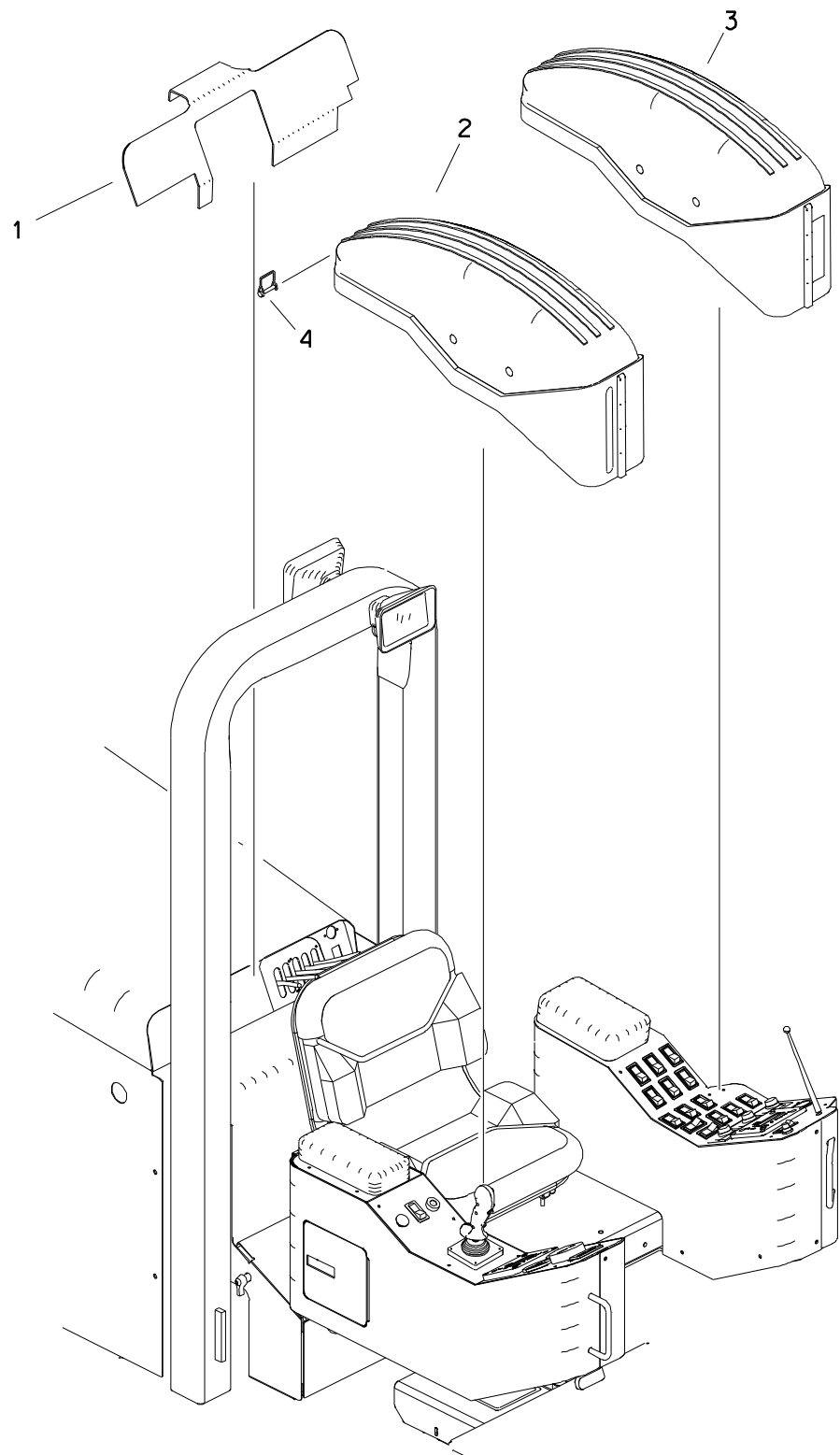

VANDAL COVERS

REF NO.	PART NUMBER	QTY	DESCRIPTION	REMARKS
	N/A		VANDAL KIT	
1.	310-961	1	GAUGE VANDAL COVER	
2.	310-960	1	RIGHT SIDE VANDAL COVER	
3.	315-790	1	LEFT SIDE VANDAL COVER	
4.	110-032	2	SNAPPER PIN (5/16" X 2-1/2")	

FOOTNOTES

TOOL BOX

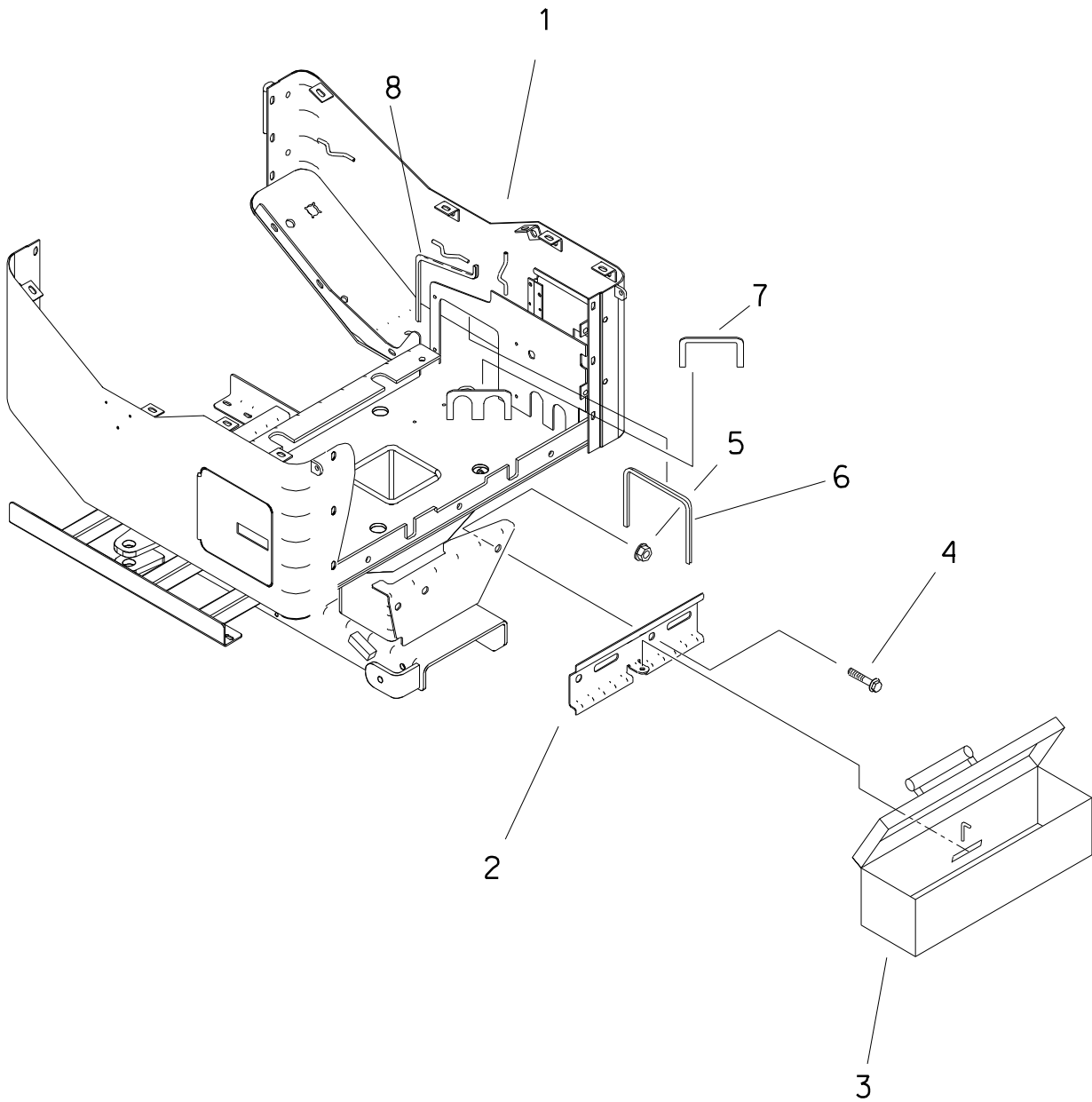

TOOL BOX

REF NO.	PART NUMBER	QTY	DESCRIPTION	REMARKS
1.	308-794	-	OPERATOR FRAME	
	313-778	-	PLATE	SEE FOOTNOTE 1.
2.	313-777	1	BRACKET	
3.	313-776	1	TOOL BOX	
4.	106-471	2	FLG SCREW (M16-2.00 X 30MM)	
5.	106-442	2	FLG LOCKNUT (M16-2.00,PRV TRQ)	
6.	116-789	AR	RUBBER EDGE TRIM 1/8" (FT)	USE 1 AT 18"
7.	116-789	AR	RUBBER EDGE TRIM 1/8" (FT)	USE 2 AT 10"
8.	116-789	AR	RUBBER EDGE TRIM 1/8" (FT)	USE 1 AT 19"

FOOTNOTES

1. EARLY MACHINES WILL REQUIRE THIS PART TO BE WELDED TO OPERATOR CONSOLE.

MISCELLANEOUS

SAE Bolt and Nut Torque Value Chart

Grade 5: UNC or UNF Thread

Size	Hex nut, or bolt tapped into hex nut, or d&t hole		Hex top deformed locknut		Flange nut, locknut, or bolt tapped into flange nut or d&t* hole	
	ft•lb	N•m	ft•lb	N•m	ft•lb	N•m
1/4	12	16	8	11	20	27
5/16	25	34	15	20	45	60
3/8	40	54	25	34	75	100
7/16	65	90	40	55	125	170
1/2	100	135	60	80	190	260
9/16	150	200	90	125	270	370
5/8	200	270	120	165	370	500
3/4	350	475	210	285	650	880
7/8	560	760	340	460	1250	1425
1	840	1140	500	680	1580	2145
1-1/8	1030	1400	320	840	1950	3645
1-1/4	1460	1980	880	1195	2760	3475

Grade 8: UNC or UNF Thread

Size	Hex nut, or bolt tapped into hex nut, or d&t hole		Hex top deformed locknut		Flange nut, locknut, or bolt tapped into flange nut or d&t* hole	
	ft•lb	N•m	ft•lb	N•m	ft•lb	N•m
1/4	14	19	10	14	24	33
5/16	30	40	18	25	50	70
3/8	55	73	35	50	90	125
7/16	85	115	50	70	140	190
1/2	130	175	80	110	220	300
9/16	190	260	110	150	310	420
5/8	260	355	160	245	430	585
3/4	450	610	270	365	750	1015
7/8	730	990	440	600	1210	1640
1	1090	1480	650	880	1320	2465
1-1/8	1550	2100	930	1260	2580	3500
1-1/4	2180	2955	1310	1780	3640	4935

*drilled and tapped

Metric Bolt and Cap Screw Torque Values

Size	Class 4.8				Class 8.8 and 9.8				Class 10.9				Class 12.9			
	Lubricated		Dry		Lubricated		Dry		Lubricated		Dry		Lubricated		Dry	
	N•m	ft•lb	N•m	ft•lb	N•m	ft•lb	N•m	ft•lb	N•m	ft•lb	N•m	ft•lb	N•m	ft•lb	N•m	ft•lb
M6	4.8	3.5	6	4.5	9	6.5	11	8.5	13	9.5	17	12	15	11.5	19	14.5
M8	12	8.5	15	11	22	16	28	20	32	24	40	30	37	28	47	35
M10	23	17	29	21	43	32	55	40	63	47	80	60	75	55	95	70
M12	40	29	50	37	75	55	95	70	110	80	140	105	130	95	165	120
M14	63	47	80	60	120	88	150	110	175	130	225	165	205	150	260	190
M16	100	73	125	92	190	140	240	175	275	200	350	225	320	240	400	300
M18	135	100	175	125	260	195	330	250	375	275	475	350	440	325	560	410
M20	190	140	240	180	375	275	475	350	530	400	675	500	625	460	800	580
M22	260	190	330	250	510	375	650	475	725	540	925	675	850	625	1075	800
M24	330	250	425	310	650	475	825	600	925	675	1150	850	1075	800	1350	1000
M27	490	360	625	450	950	700	1200	875	1350	1000	1700	1250	1600	1150	2000	1500
M30	675	490	850	625	1600	950	1650	1200	1850	1350	2300	1700	2150	1600	2700	2000
M33	900	675	1150	850	1750	1300	2200	1650	2500	1850	3150	2350	2900	2150	3700	2750
M36	1150	850	1450	1075	2250	1650	2850	2100	3200	2350	4050	3000	3750	2750	4750	3500

Do not use these values if a different torque value or tightening procedure is given for specific application. Torque values listed are for general use only. Check tightness of fasteners periodically.

Shear bolts are designed to fail under predetermined loads. Always replace shear bolts with identical property class fasteners.

Fasteners should be replaced with the same or higher property class. If higher property class fasteners are used, these should only be tightened to strength of original.

Make sure fastener threads are clean and that the threads are properly started. This will prevent them from cross threading or galling when tightened.

Tighten plastic insert or crimped type steel locknuts to approximately 50% of dry torque indicated on chart. Apply torque to the nut - not the bolt head. Tighten toothed or serrated type locknuts to full torque value.

LUBRICATED means coated with lubricant. DRY means plain or zinc plated without any type of lubricant.

Hydraulic Cylinder Bolt Torque Chart

Bolt Size (inch)	Bolt Part No.	Cylinder Repair Kit Part No.	Torque (ft•lb)	Torque (N•m)
1/2	106-096	190-165	90-100	120-135
5/8	106-097	190-166 & 190-169	180-200	245-270
3/4	106-098	190-167 & 190-170	290-325	395-440
7/8	106-122	190-172 & 190-174	410-640	550-625
1	106-145	190-175 & 190-189	630-700	855-950
1-1/8	106-146	190-177	770-850	1045-1170

As a general rule:

- 1/2-inch bolts are used in cylinders with 1-inch rods
- 5/8-inch bolts are used in cylinders with 1 1/4-inch rods
- 3/4-inch bolts are used in cylinders with 1 1/2-inch rods
- 7/8-inch bolts are used in cylinders with 1 3/4-inch rods
- 1-inch bolts are used in cylinders with 2-inch rods (one with 1 3/4-inch)
- 1-1/8-inch bolts are used in cylinders with 2-1/4-inch rods

IMPORTANT: Do not reuse cylinder piston bolts when rebuilding a hydraulic cylinder. Each cylinder repair kit contains a new bolt. Use it. Lubricate lightly and torque to value shown on chart.

SAE & ORS Hydraulic Fitting Replacement O-Ring Chart

Fraction Size	Dash Size	SAE (Port Seal O-Ring)		ORS (Face Seal O-Ring)	
		Thread Size	O-Ring P/N	Thread Size	O-Ring P/N
1/16	1	NA	NA	NA	NA
1/8	2	5/16 - 24	NA	NA	NA
3/16	3	3/8 - 24	NA	NA	NA
1/4	4	7/16 - 20	155-760	9/16 - 18	157-037
5/16	5	1/2 - 20	NA	NA	NA
3/8	6	9/16 - 18	155-705	11/16 - 16	157-038
1/2	8	3/4 - 16	155-706	13/16 - 16	157-039
5/8	10	7/8 - 14	155-707	1 - 14	157-040
3/4	12	1-1/16 - 12	155-709	1-3/16 - 12	157-017
7/8	14	1-3/16 - 12	155-747	NA	NA
1	16	1-5/16 - 12	155-748	1-7/16 - 12	155-714
1-1/4	20	1-5/8 - 12	155-702	1-11/16 - 12	NA
1-1/2	24	1-7/8 - 12	157-001	2 - 12	NA
2	32	2-1/2 - 12	NA	NA	NA
2-1/2	40	3 - 12	NA	NA	NA
3	48	3-1/2 - 12	NA	NA	NA

Thread size indicates the diameter of the threaded area in fractions of an inch and number of threads per inch.

NA = not a current CMW part numbered o-ring, or dash size does not occur in current CMW applications

SAE = straight thread fitting that seals by sandwiching a hard o-ring between a shoulder on the male part and an angular surface at the mouth of the female port.

ORS = o-ring face seal; a type of fitting that seals by compressing a hard, captive o-ring between two flat parallel faces, one grooved for the o-ring and the other plain to act as the sealing surface

AT/JT4020 Rack & Pinion

Related Publications

Component	Ass'y	P/N
Model:		
JT4020 T3/AT4020 T3.....	Parts Manual	053-1216
JT4020 T3/AT4020 T3.....	Operators Manual	053-1088
JT4020 T3/AT4020 T3.....	Repair Guide (Service Manual)	N/A
JT4020 T3/AT4020 T3.....	Technical Supplement	053-1215
Engine:		
Cummins.....	Operators Manual – QSB 6.7.....	194-294 053-1035

Filters

Engine:		
Air Filter Parts Ass'y		194- 672
Element (primary)		500-1086
Element (safety)		500-1087
Oil Filter Element (spin-on).....		195-1034
Fuel Filter Primary Element.....		195-1035
Fuel Filter Secondary Element		195-1036
Hydraulic:		
Oil Filter Element (_ - / _ -UNF, spin-on) – Charge Remote		149-939
Element (_ - / _ -UNF, spin-on, Micron 10, Replacement) - Return		157-486
Element (1-UNF, spin-on) – Carriage Case Drain		155-910

Optional Kits

O-ring Repair Kit - FLG, ORS & SAE (15 different O-rings)	190-051
O-ring Repair Kit – Field Service (46 different O-rings)	190-052



Parts Manual Change Request

(Please print clearly)

Date: _____ Dealer No. (required): _____

Your Name: _____ Position: _____

Phone: _____ Fax: _____ E-mail: _____

Publication Information:

Parts Manual No.: _____ - _____ Model: _____

Illustration Part No.:	Manual Page No.:
1. _____ - _____	1. _____
2. _____ - _____	2. _____
3. _____ - _____	3. _____

Nature of Change Request:

- Text
 Graphics
 Missing Information

Describe change requested (if possible, include copy of publication page with changes marked.):

Please fax completed form to
Parts Manual Department (580) 572-3525

Thank you for taking the time to submit this request. We will contact you if further information is needed to process your request.

**A Note To
Ditch Witch
Equipment Owners:**

If your equipment was purchased through a Ditch Witch dealer, there is no need to read further.

However, if you purchased from any other source, please fill out the form on the reverse side and return it to us.

This will enable you to receive updates on this equipment as well as information on new products of interest.

Thanks for using Ditch Witch equipment.

(Please Fold Along This Line And Seal At Bottom With Tape)



**NO POSTAGE
NECESSARY
IF MAILED
IN THE
UNITED STATES**

BUSINESS REPLY MAIL
FIRST CLASS PERMIT NO 23 PERRY OKLAHOMA

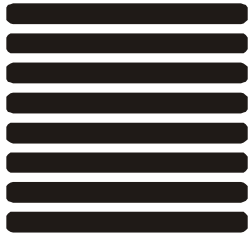

POSTAGE WILL BE PAID BY

**The Charles Machine Works, Inc.
P.O. Box 66
Perry, Oklahoma 73077-9989**



Ditch Witch® Registration Card

Please Type or Print All Information

Purchaser's Company Name

Attention

Street Address or P.O. Box

City County

State Zip Nation

()

Phone Number With Area Code

Model S rial Number

Attachments/Accessories Serial Numbers

Attachments/Accessories Serial Numbers

Attachments/Accessories Serial Numbers

Name of Ditch Witch Dealership

Your Signature